

SIGMA SELECT 300/400/550 COMPACT/S

Brugsvejledning

User guide

Betriebsanleitung

Guide de l'utilisateur

Bruksanvisning

Guida per l'utilizzatore

Gebruikershandleiding

Käyttöohje



MICATRONIC
WELDING VALUE

50115048 D2 Valid from 2023 week 04

Contents

Dansk.....	3
English.....	17
Deutsch	31
Français.....	45
Svenska.....	59
Italiano	73
Nederlands	87
Suomi.....	101

Tilslutning og ibrugtagning

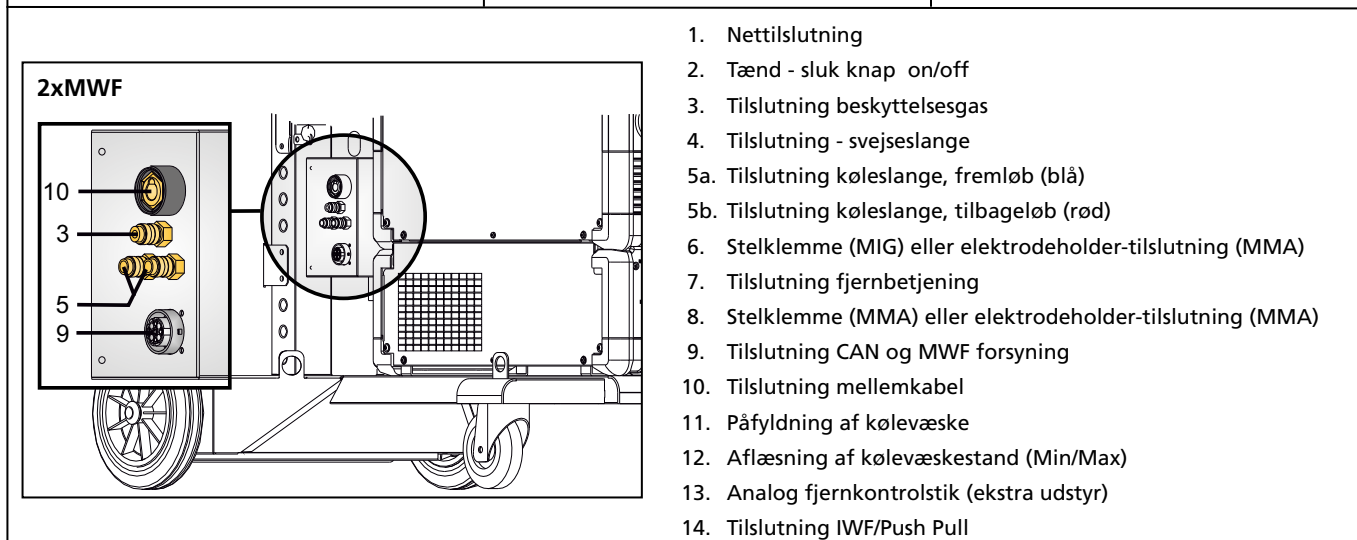
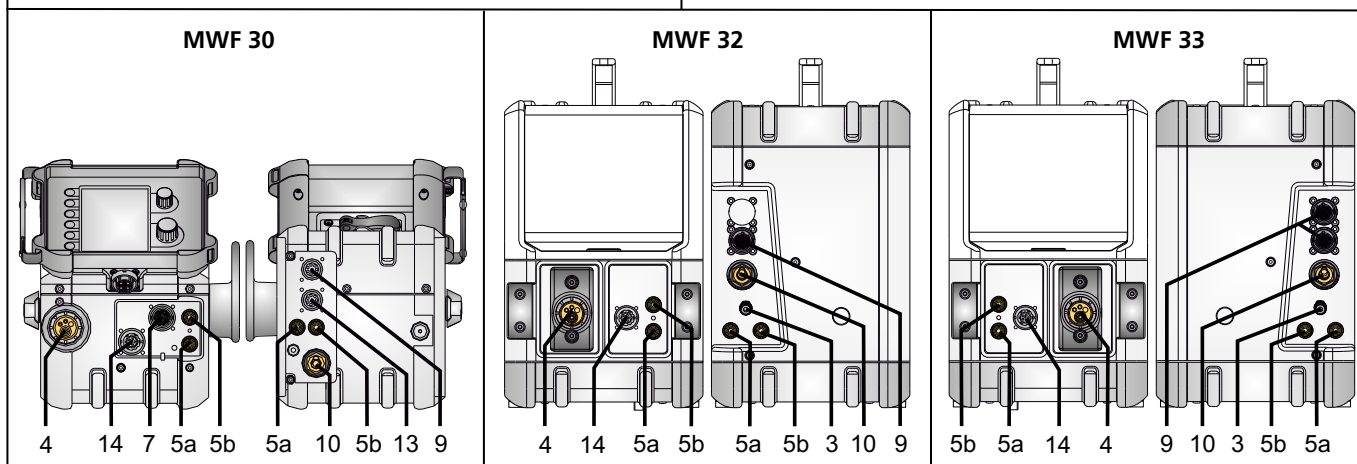
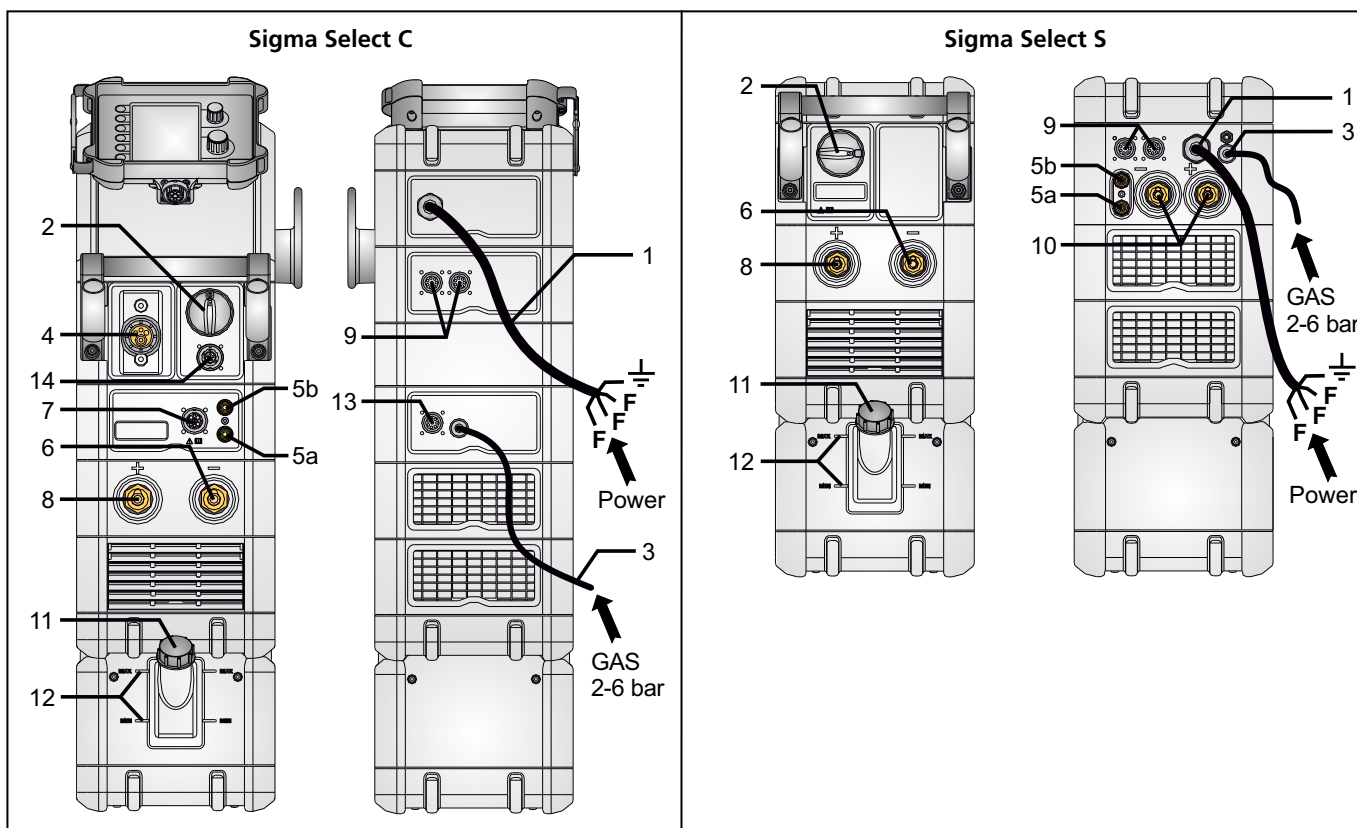

Tilslutning og ibrugtagning



Advarsel

Læs advarsel og brugsanvisning omhyggeligt igennem inden installation og ibrugtagning og gem til senere brug.

Installation

Nettilslutning

Tilslut maskinen til den netspænding den er konstrueret til. Se typeskiltet (U₁) bag på maskinen.

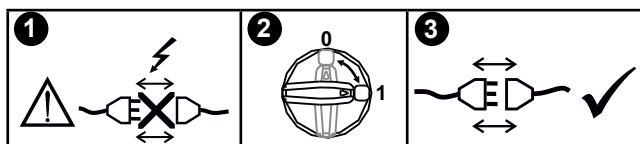
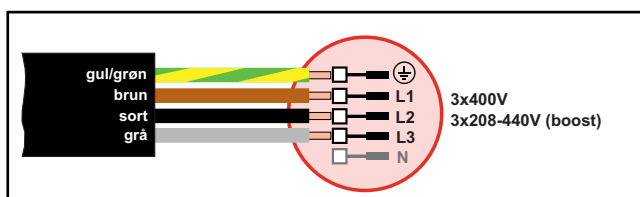

Stabiliseringskit

Strømkilden kan konfigureres med et stabiliseringskit som beskyttelse mod større spændingsvariation, f.eks. ved generatortrub, hvor maskinen er tilkoblet separat netforsyning.

Tilslutning af beskyttelsesgas

Gaslangen, som udgår fra bagsiden af maskinen (3), tilsluttes en gasforsyning med en reduktionsventil (2-6 bar). (Obs. Nogle typer reduktionsventiler kan kræve højere udgangstryk end 2 bar for at fungere optimalt). En/to gasflasker kan fikseres bag på vognen.

Gasforbrug

Afhængigt af svejseopgave, gastype og svejseøm kan gasforbruget typisk variere fra 6-7 l/min. ved lave ampere (<25A) og op til 27 l/min. ved maks. ampere.

Materialeforbrug

Materialeforbrug kan beregnes ved at lave beregningen svejsetid i minutter x trådhastighed (m/min) x vægt pr. meter på det aktuelle tilsatsmateriale.

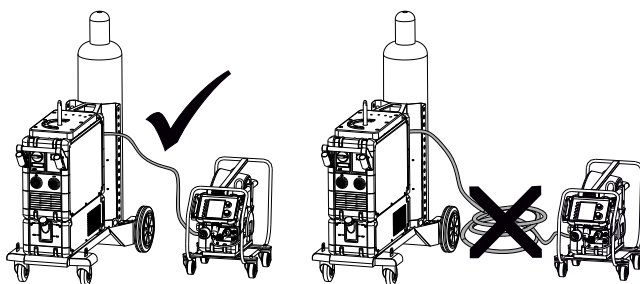

ADVARSEL

Når der trykkes på svejse slangens kontakt/tast er der spænding på svejsetråden/elektroden.

Tilslutning af svejse slang

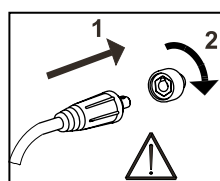
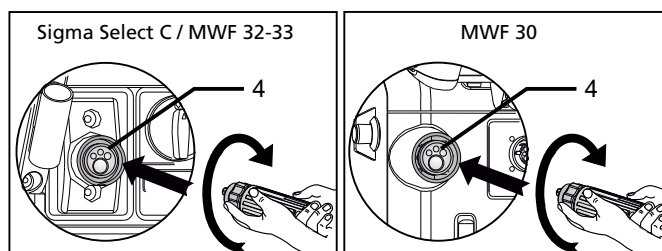

Vigtigt!

Når stelkabel og svejse slang tilsluttes maskinen, er god elektrisk kontakt nødvendig, for at undgå at stik og kabler ødelægges.

Tilslutning af elektrodeholder for MMA

Elektrodeholder og stelkabel tilsluttes plusudtag (10) og minusudtag (8). Polariteten vælges efter elektrodeleverandørens anvisning.

Anbefalede kabelstørrelser

Svejsestrøm	DC	PULS
200 A	35 mm ²	35 mm ²
300 A	50 mm ²	70 mm ²
400 A	95 mm ² / 2x50 mm ²	95 mm ² / 2x50 mm ²
550 A	2x70 mm ²	2x70 mm ²

Svejseproces	Afstand til arbejdslemne (a+b)	Total kabellængde i svejsekredsløb (a+b+c)
MIG - IAC og puls	10 m	20 m
MIG - ingen puls	30 m	60 m

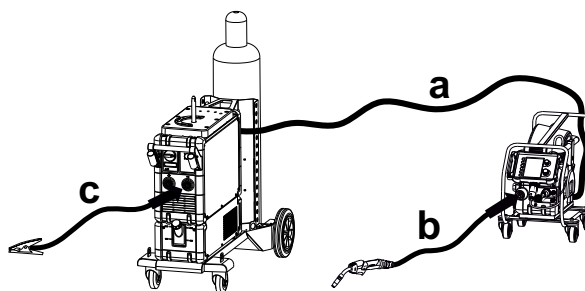

Justering af trådbremse

Bremser justeres så stramt at trådrullen standser inden svejsetråden kører ud over kanten på rullen. Bremskraften er afhængig af vægten på trådrullen, og trådhastigheden. Fabriksindstillet til 15kg.

Justering:

- Afmonter drejeknappen ved at stikke en tynd skruetrækker ind bagved knappen og ryk derefter knappen ud.
- Juster trådbremser ved at spænde eller løsne låsemøtrikken på trådnavets aksel.
- Monter drejeknappen igen.

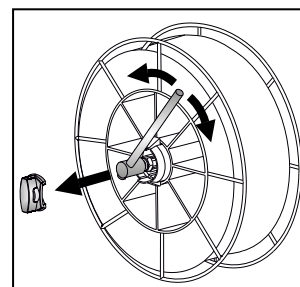

Tilslutning og ibrugtagning

Løfteanvisning

Når maskine eller MWF enhed løftes, skal løftepunkterne, som vises på figuren, anvendes.

Maskinen må ikke løftes med monteret gasflaske!

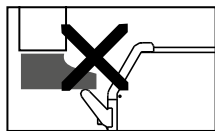
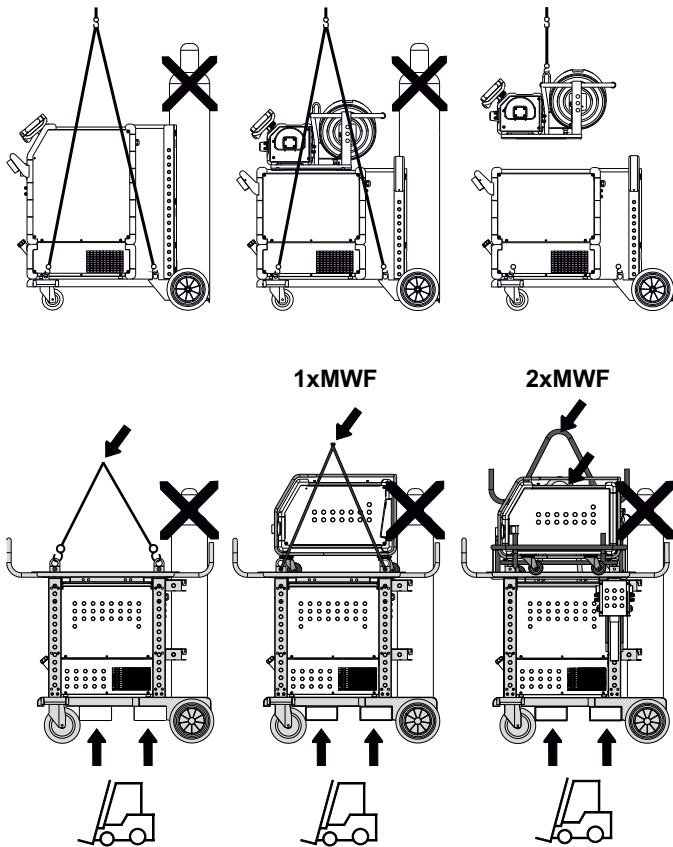

Løft ikke maskinen i håndtaget.
Træd ikke op på håndtaget.

Montering af fjernkontrol

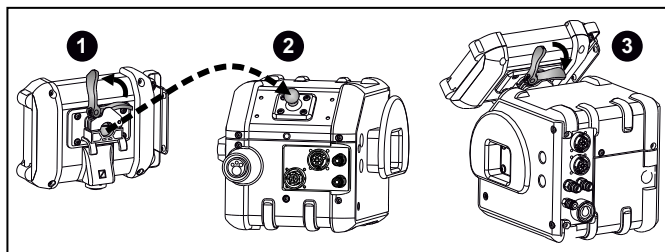

Kabeloprul MWF 30

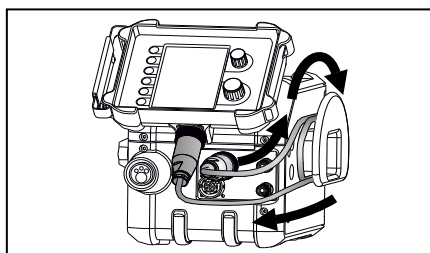

MCU udluftning

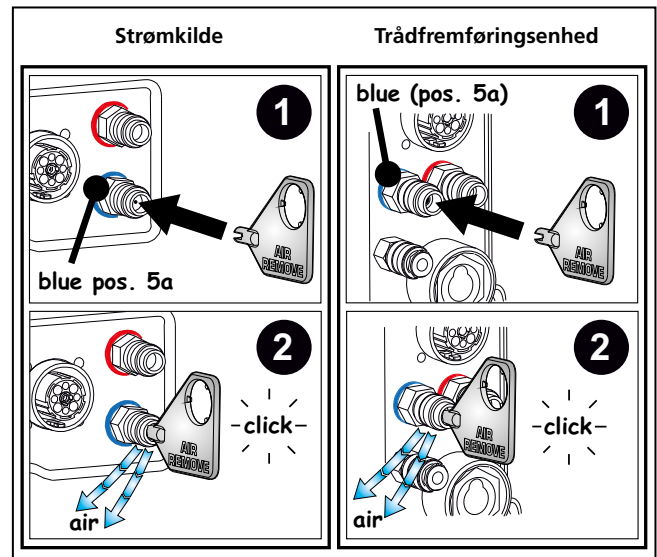

Låse- og drejefunktion MWF

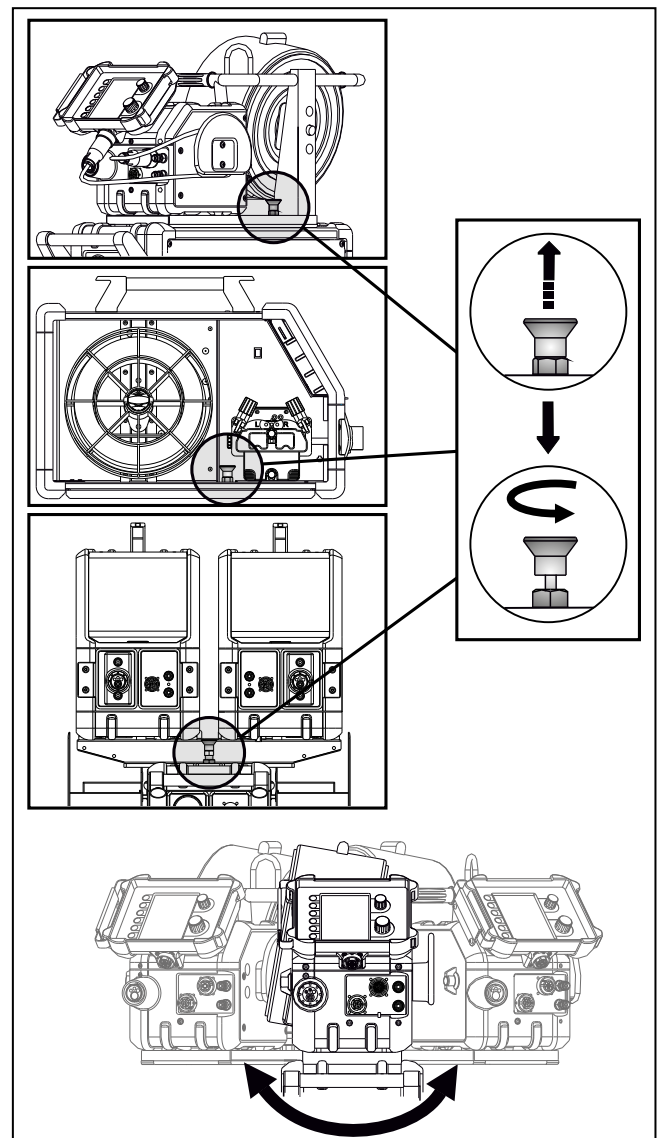

Tilslutning og ibrugtagning

Montering af dele i trådfremføring

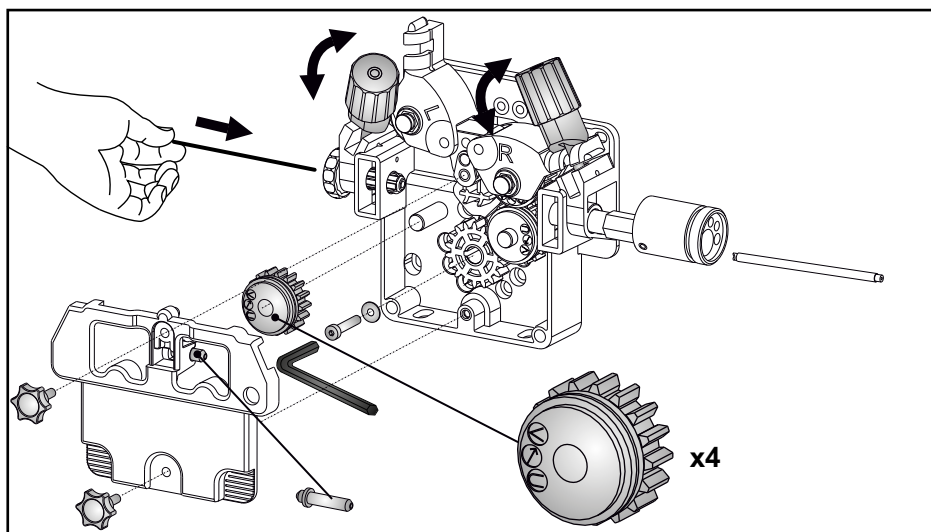

Fingerskruens tryk indstilles, således at trådtrisserne netop glider på tråden, når denne bremses ved kontaktdysen

Rangering af tråd frem/retur

Når der ikke svejdes, kan rangering af tråd startes ved tryk på en af tasterne eller fra robotinterface, hvis MWF30 anvendes i en robotløsning.

Rangering

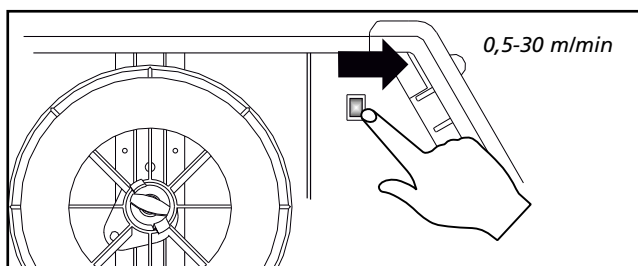

Rangering MWF 30

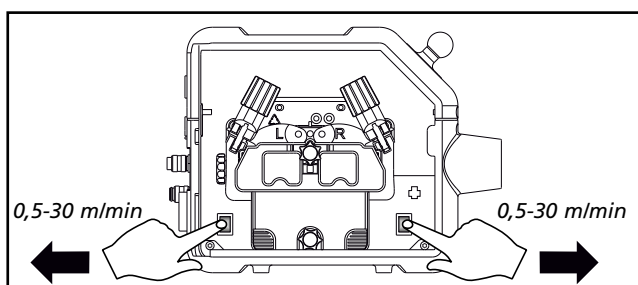

Rangering Graphical

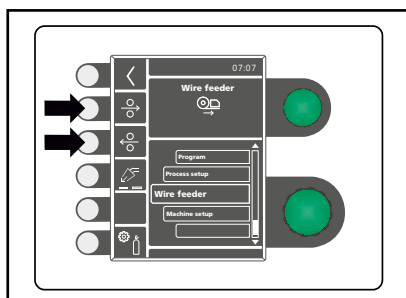

Software opdatering

- Indsæt SD-kortet
- Tænd maskinen
- Vent indtil enheden indikerer, at opdatering er afsluttet
- Sluk maskinen og tag SD-kortet ud
- Maskinen er nu klar til brug

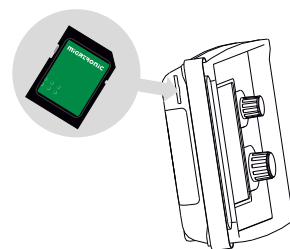

Strømkilde og alle tilkoblede enheder får den nye software indlæst.

Software kan downloades fra <http://migatron.com> til et SD-kort. SD-kortets filsystem skal være formateret til FAT32.

VIGTIGT:

Software skal gemmes i mappestrukturen: //MIGA_SW/SIGMA/

Licens SW

Ved tilkøb af ekstra programmer eller særlige funktioner skal MigaLic.dat filerne indlæses på samme vis som SW-pakker. Husk at gemme en sikkerhedskopi af filerne.

MigaLic.txt filen indeholder information om maskinens licensnummer og de gemte licenser på SD-kort.

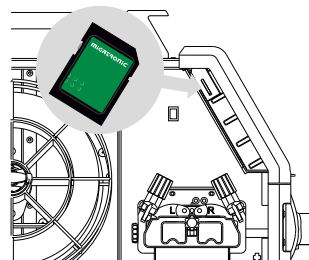

BASIC - Specielle funktioner

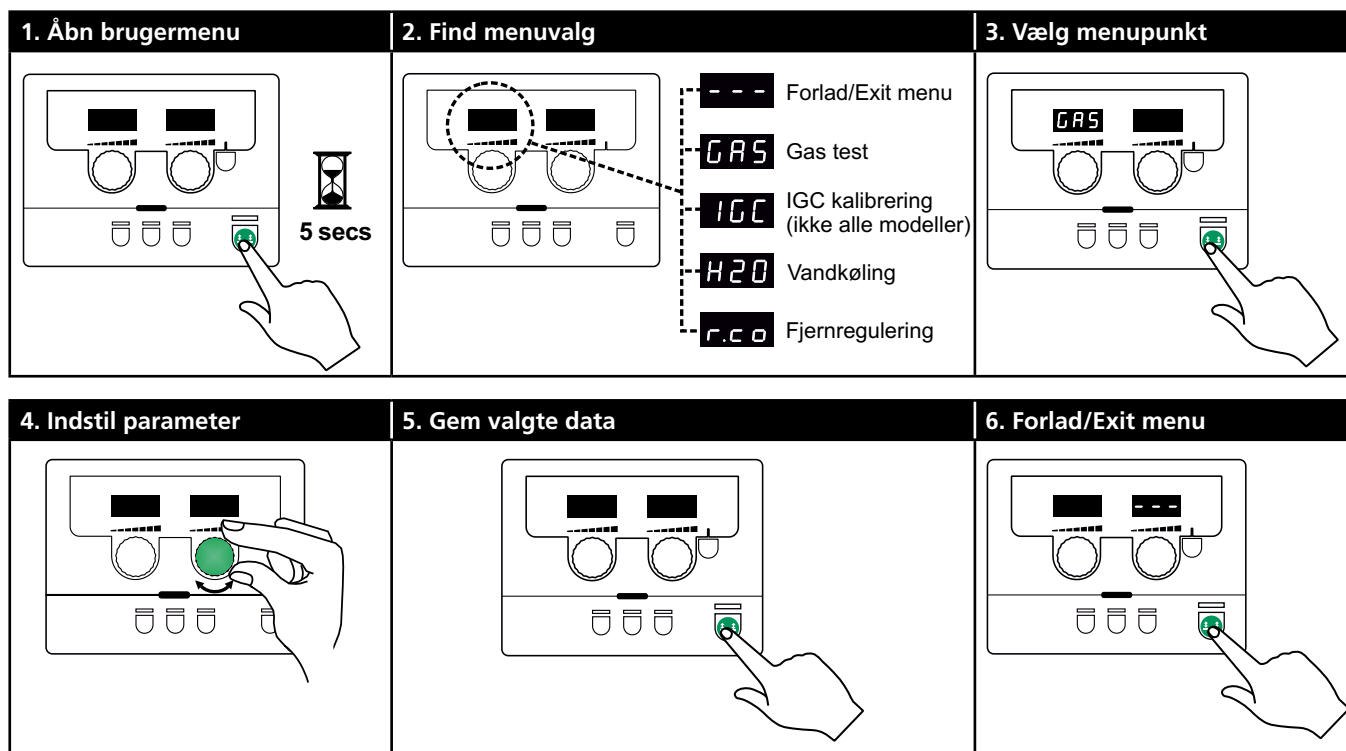

Parametre og menuvalg

Brugermenuen åbnes med et langt tryk på -knappen. Drej på venstre drejeknap til det ønskede menuvalg vises. Højre drejeknap kan bruges til at ændre indstillinger, som vises i højre display. Med et kort tryk på -knappen aktiveres funktioner som f.eks. gastest.

Følgende diagram viser alle funktioner og parametre i brugermenuen.

--- GAS IGC H2O r.c.o

--- Forlader menuen hvis der trykkes på -knappen.

GAS GAS test
Gasventilen åbnes og lukkes med -knappen. Gasgennemstrømningen kan indstilles med højre drejeknap, hvis IGC-kit er installeret.

IGC IGC-kalibrering
Kun synlig når IGC-kit er installeret.
IGC-kalibrering startes med -knappen.

H2O Vandkøling
Kun synlig når kølemodul er installeret.

0: Vandkøling OFF
1: Vandkøling ON

r.c.o Indstilling af fjernregulering
Indstilling kan ændres med højre drejeknap.

Følgende indstillinger understøttes:

0: Inaktiv

1: Dialog-brænder (varenr. 80100402)

2: Analog fjernregulering (varenr. 78815029)

BASIC - Specielle funktioner

Konfiguration af fjernkontrol

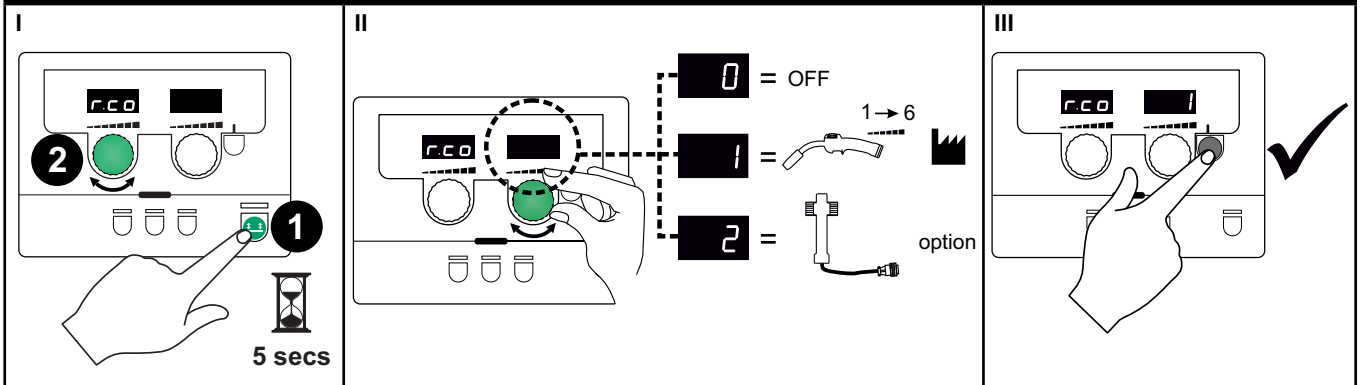

Låsefunktion /

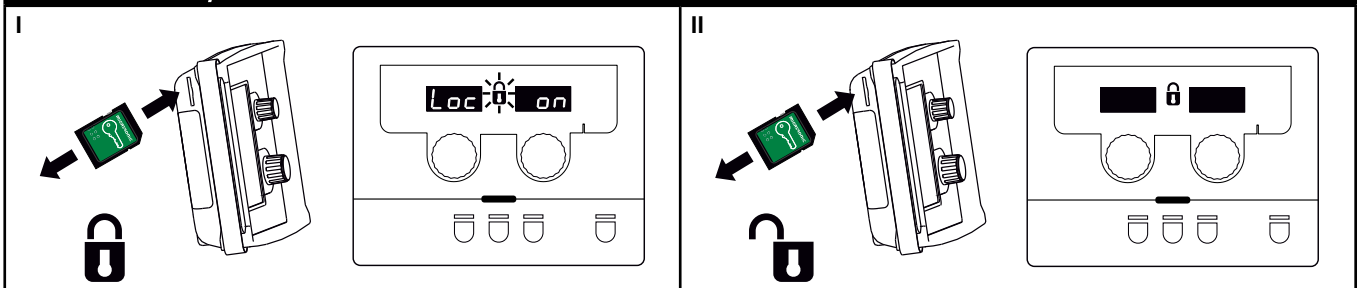

Kalibrering af gasflow (ikke alle modeller)

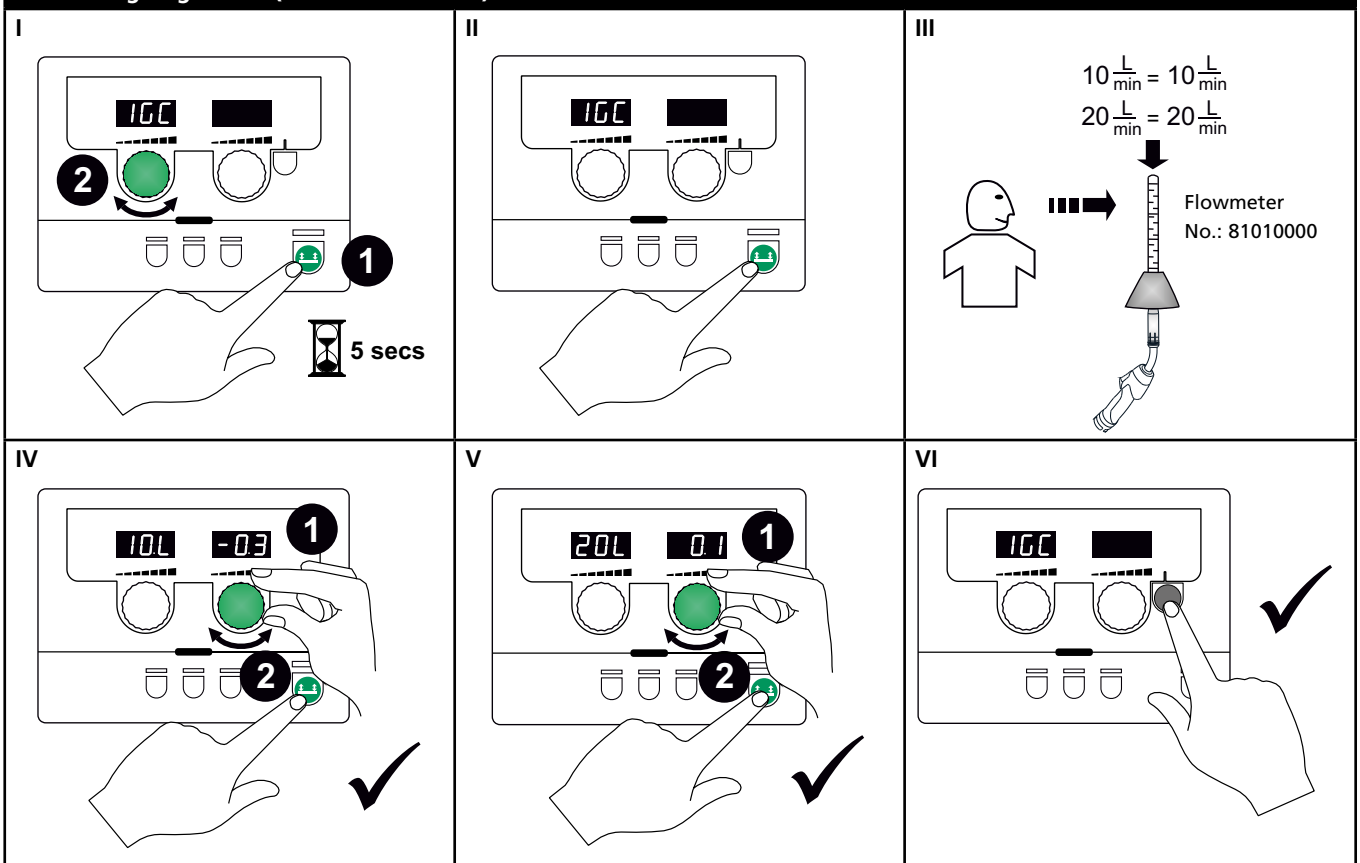

BASIC - Specielle funktioner

Visning af softwareversioner / Licensnr.

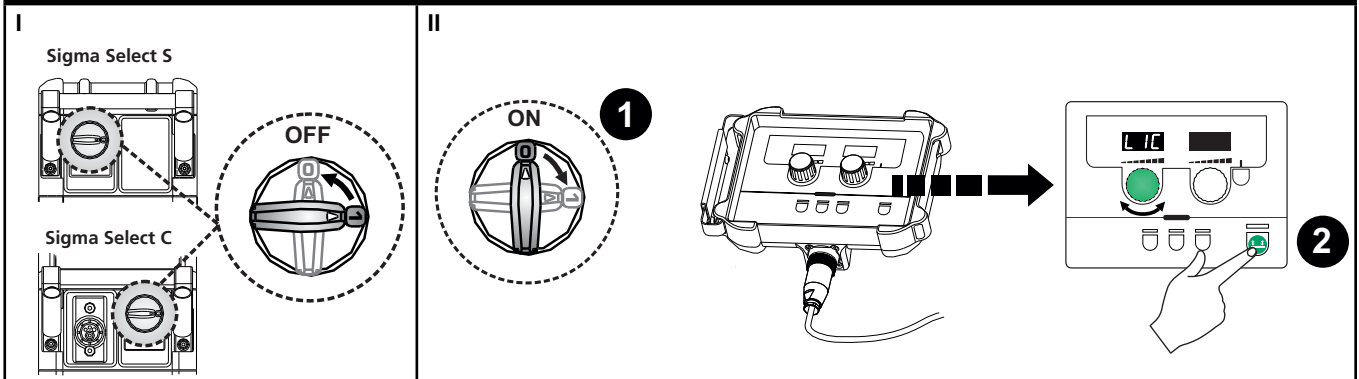

1. Licensnr.

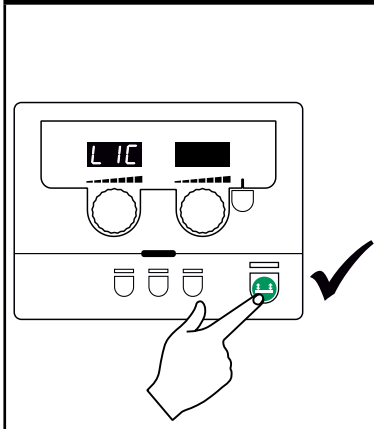

2. Se licensnr. (12 cifre)

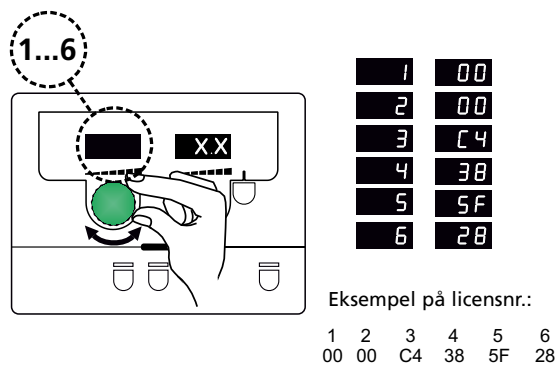

3. Retur til SW-versioner

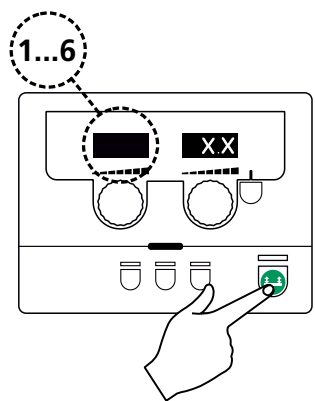

4. Vælg SW

- Basic remote **1**
- Welding package **2**
- Main controller **3**
- "..." **4**
- "..." **5**
- Wire feeder **6**
- Wire feeder **7**
- Arc controller **8**
- "..." **9**
- "..." **10**
- "..." **11**
- "..." **12**
- "..." **13**
- "..." **14**
- "..." **15**
- "..." **16**
- Water controller **17**
- Smart Torch **18**

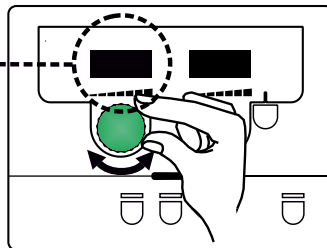

5. Forlad/Exit menu

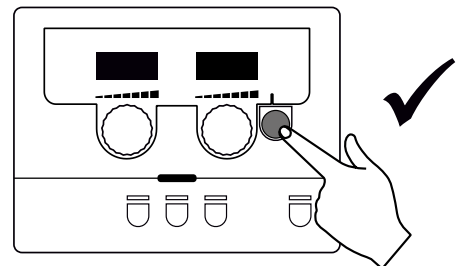

"..." not supported

BASIC - Fejlhåndtering

Fejlkode	Årsag og udbedring
E20-00	Der er ingen software i kontrolboksen
E20-02	Download software til SD-kortet, sæt SD-kortet i boksen og tænd maskinen. Udskift evt. SD-kortet.
E21-00	
E21-06	
E21-08	
E20-01	SD kortet er ikke formateret
E21-01	Formater SD-kortet i en PC som FAT og download software til SD-kortet. Udskift evt. SD-kortet.
E20-03	SD-kortet har flere filer med samme navn
E21-02	Slet SD-kortet og download software igen.
E20-04	Kontrolboksen har forsøgt at indlæse flere data end den kan have i hukommelsen Indlæs SD-kortet igen eller udskift SD-kortet. Tilkald MIGATRONIC Service, hvis problemet ikke løses.
E20-05	Software på SD-kortet er låst til en anden type kontrolboks
E20-06	Anvend et SD-kort med software som passer til din type kontrolboks.
E20-07	Den interne kopibeskyttelse tillader ikke adgang til mikroprocessoren Indlæs SD-kortet i maskinen igen eller tilkald MIGATRONIC Service.
E20-08	Kontrolboksen er defekt
E20-09	Tilkald MIGATRONIC Service.
E21-05	
E20-10	Den indlæste fil er defekt
E21-07	Indlæs SD-kortet igen eller udskift SD-kortet.
E21-03	Den indlæste svejseprogrampakke passer ikke til kontrolboksen
E21-04	Anvend et SD-kort med software som passer til din type kontrolboks.
Err GAS	Gasfejl Kontroller gastilførslen. Gasfejl afmeldes med et kort tryk på en vilkårlig tast.
E02-04	CAN – kommunikationsfejl Check mellemkabel/stik
E11-20	Strømsensorfejl 1. Check strømsensor 2. Tilkald MIGATRONIC service

Fejlsymboler

Temperaturfejl

Overophedningsindikatoren lyser, hvis svejsningen er blevet afbrudt på grund af overophedning af maskinen.

Lad maskinen være tændt, indtil den er afkølet af den indbyggede blæser.



Strømfejl

Indikatoren blinker, når startstrømmen eller svejsestrømmen er højere end maskinens ydeevne tillader. Kontroller at tråd hastighed/strøm og spænding er korrekt indstillet.

Visning af fejlkode

Indikatoren blinker, når der opstår andre typer fejl. Samtidigt vises fejlkode i displayet.

Udvalgte fejlkode

⚡ E11 15 Overspændingsfejl

Ikonet vises, når netspændingen er for høj.

Tilslut maskinen til 400V AC, +/-15% 50-60Hz.

⚡ Err H20 Kølefejl

Kølefejl vises i tilfælde af at kølevandet ikke kan cirkulere som følge af forkert tilslutning eller tilstopning. Kontroller at køleslangerne er korrekt tilsluttet, efterfyld vandbeholderen og efterse svejse slange og tilslutningsstudser.

Hvis kølevæskens viskositet er reduceret grundet lave temperaturer, skal Migatronic standard kølevæske udskiftes med 99290515 BTC-20 NF kølevæske, der er kendetegnet ved sin ekstremt lave ledningsevne og høje viskositet ved temperaturer ned til -17°C.

Skyt systemet igennem inden påfyldning af ny type kølevæske.

Kølefejlen afmeldes med et kort tryk på -knappen.

⚡ Err GAS Gasfejl (IGC)

Gasfejl kan skyldes for lavt eller for højt tryk på gastilførslen. Kontroller at trykket på gastilførslen er højere end 2 bar og mindre end 6 bar, svarende til 5 l/min og 27 l/min.

Gasfejl kan sættes ud af funktion ved at indstille manuel gasflow til 27 l/min. Gasfejlen afmeldes med et kort tryk på -knappen.

Trådfejl

⚡ E01 00 eller ⚡ E01 01

Ikonet vises ved overbelastet trådfremføringsmotor. Trådmotoren eller magnetventil kan være defekt.

Andre fejltyper

Hvis andre fejlkode vises i display skal maskinen slukkes og tændes for at fjerne meddelelsen. Viser fejlmeddelelsen gentagne gange, er reparation af svejsemaskinen nødvendig. Kontakt din forhandler og oplys fejlkode.

Når separate enheder er tilkoblet kan følgende fejlkode vises:

⚡ E07 04 vises, når kommunikationen imellem strømkilde og den/de tilkoblede enhed(er) er forsvundet.

⚡ E07 05 vises, når motorstyringen ikke fungerer korrekt.

⚡ E07 06 vises, når motoren er overbelastet.

GRAPHICAL - Specielle funktioner

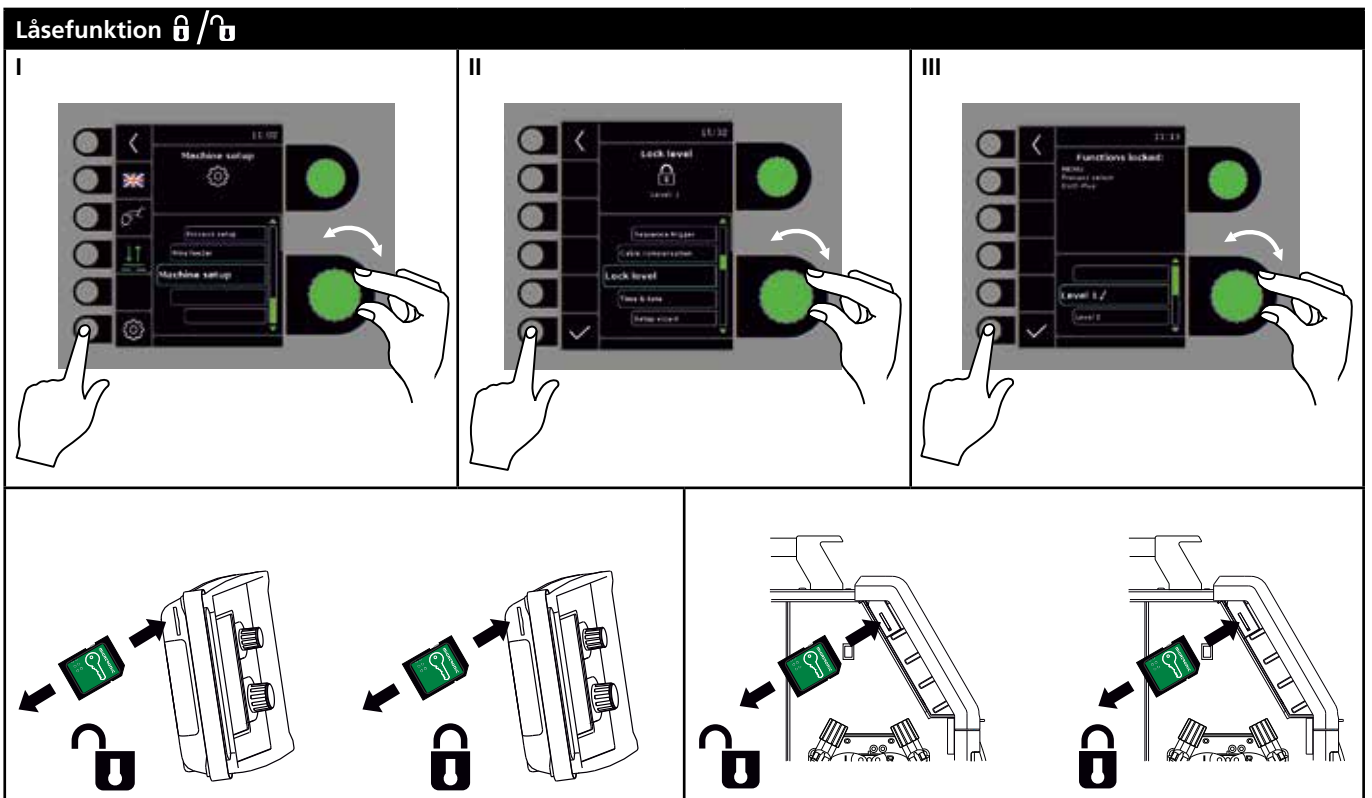

GRAPHICAL - Specielle funktioner

Software / Licenser

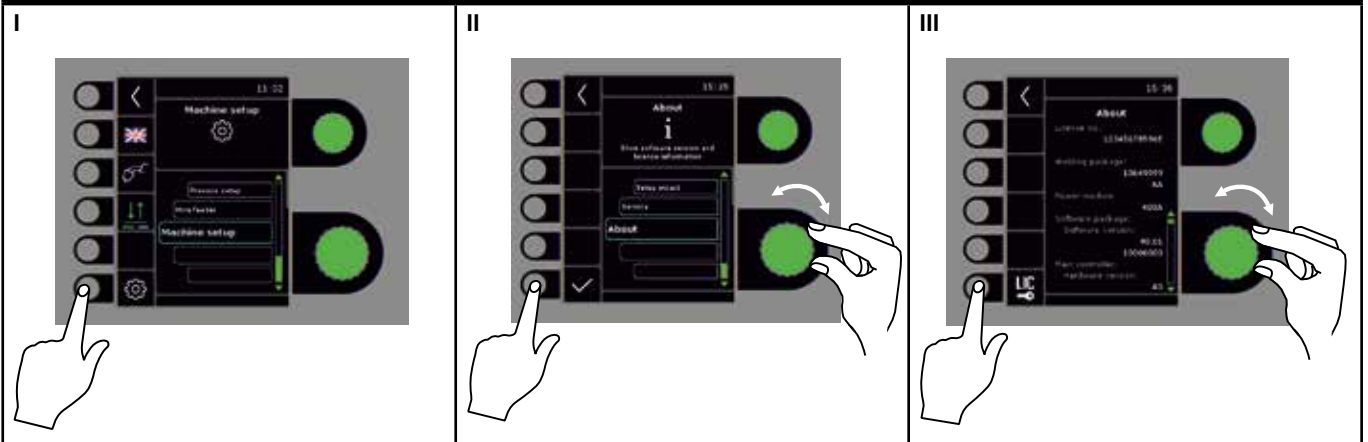

Kabelkompensering (kalibrering af modstand i svejse­slange)

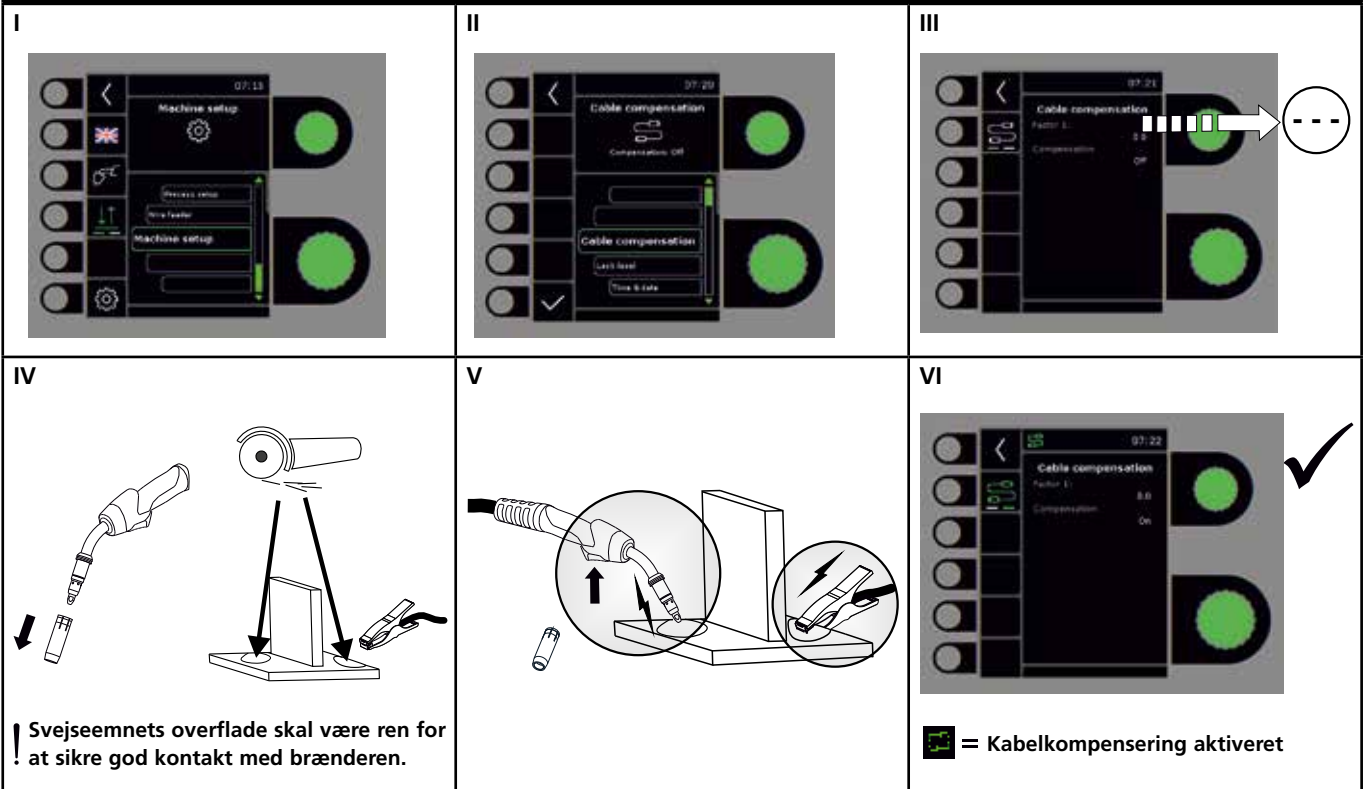

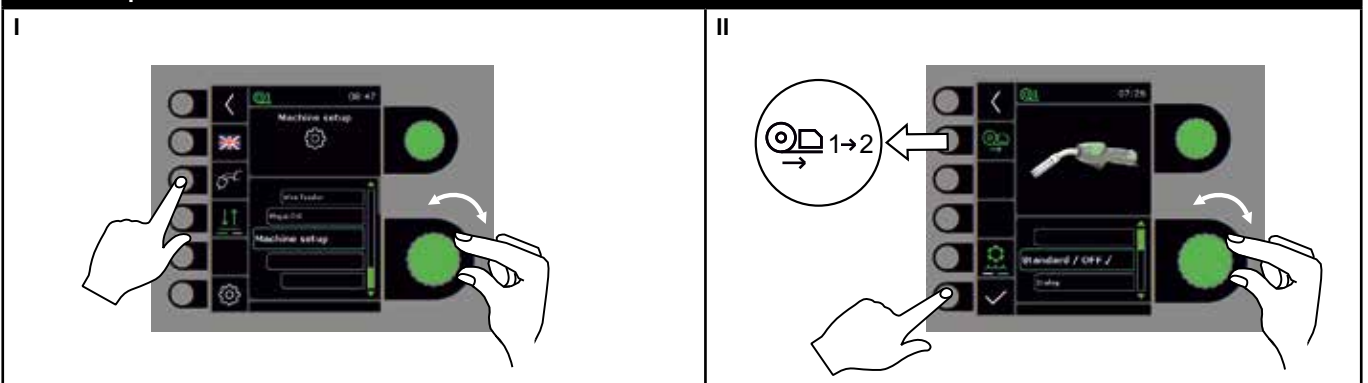

Torch setup

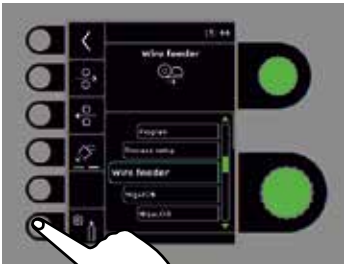

GRAPHICAL - Specielle funktioner

Kalibrering af gasflow (ikke alle modeller)

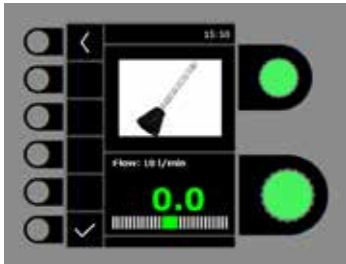
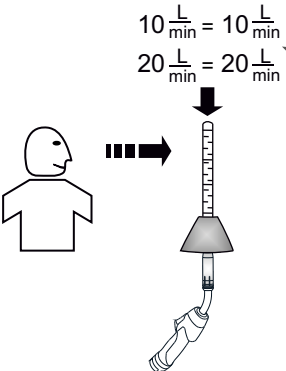
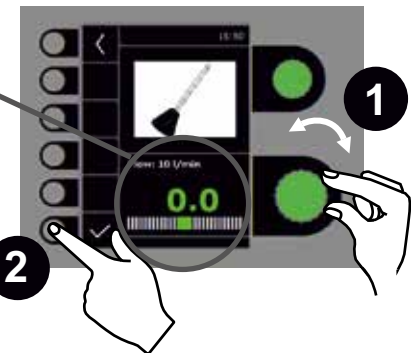
<p>I</p>  <p>A hand icon points to the 'Flow Function' option in the menu.</p>	<p>II</p>  <p>A hand icon points to the 'Gas flow - IGC' screen.</p>	<p>III</p>  <p>The screen shows a needle on a scale and a flow value of 0.0.</p>
<p>IV</p>  <p>Diagram illustrating the calibration process. A person is shown breathing through a device. The flow rate is indicated as $10 \frac{L}{min} = 10 \frac{L}{min}$ and $20 \frac{L}{min} = 20 \frac{L}{min}$.</p>	<p>V</p>  <p>A hand icon points to the flow value (0.0) on the screen. A magnifying glass is shown over the flow value. Callout 1 points to the flow value, and callout 2 points to the 'Flow Function' option in the menu.</p>	

GRAPHICAL - Fejlhåndtering

SIGMA Select har et avanceret selvbeskyttelsessystem indbygget. Ved fejl lukker maskinen automatisk for gastilførslen, afbryder svejsestrømmen og stopper trådfremførelsen.

Udvalgte fejl:

Kølefejl

Kølefejl vises i tilfælde af at kølevandet ikke kan cirkulere som følge af forkert tilslutning eller tilstopning. Kontroller at køleslangerne er korrekt tilsluttet, efterfyld vandbeholderen og efterse svejse slange og tilslutningsstudser.

Hvis kølevæskens viskositet er reduceret grundet lave temperaturer, skal Migatronics standard kølevæske udskiftes med 99290515 BTC-20 NF kølevæske, der er kendetegnet ved sin ekstremt lave ledningsevne og høje viskositet ved temperaturer ned til -17°C. Skyl systemet igennem inden påfyldning af ny type kølevæske.

Kølefejlen afmeldes med et kort tryk på ✓-knappen.



Gasfejl (IGC)

Gasfejl kan skyldes for lavt eller for højt tryk på gastilførslen.

Kontroller at trykket på gastilførslen er højere end 2 bar og mindre end 6 bar, svarende til 5 l/min og 27 l/min.

Gasfejl kan sættes ud af funktion ved at indstille manuel gasflow til 27 l/min. Gasfejlen afmeldes med et kort tryk på ✓-knappen.

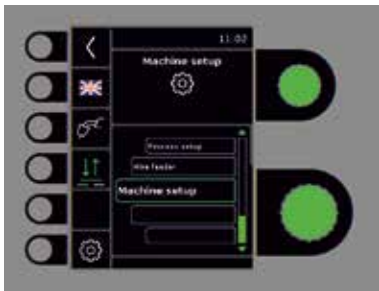
NB! Det er vigtigt, at det angivne tryk på gastilførslen kan opretholdes under svejsning.

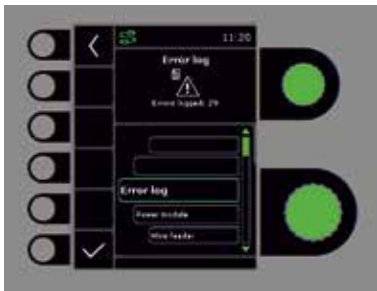
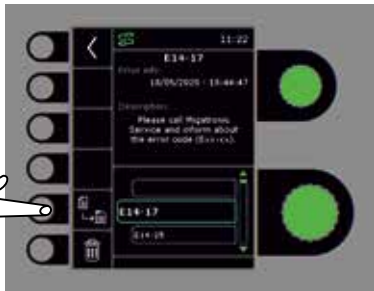
Fejllog		
I 	II 	III 
IV Fejllog Alle fejl gemmes i maskinens fejllog under menuen Service. Fejlloggen kan distribueres, når der indsættes et SD-kort og trykkes på følgende tast: Fejlloggen er nu gemt på SD-kortet. Fejlloggen kan nulstilles, når der trykkes på tasten ud for skraldespanden.		

Tekniske data 1

STRØMKILDE SIGMA Select	300		300 IAC		400		400 IAC		550	
Netspænding ±15% (50-60Hz), V	3x400		3x400		3x400		3x400		3x400	
Minimum generatorstørrelse, kVA	16		19		27		29		40	
¹ Minimum kortslutningseffekt, MVA	3,7		4,3		6,0		6,0		9,5	
Sikring, A	16		16		20		20		35	
Netstrøm effektiv, A	11,0		16,0		17,5		16,5		27,2	
Netstrøm max., A	15,4		18,3		26,0		28,2		39,2	
Effekt 100%, kVA	9,0		11,1		12,1		11,4		18,9	
Effekt max., kVA	10,7		12,7		18,0		19,5		27,1	
Effekt tomgang, W	11		13		12		13		12	
Virkningsgrad, %	87		85		89		85		90	
Powerfaktor	0,90		0,90		0,90		0,90		0,90	
	MIG	MMA	MIG	MMA	MIG	MMA	MIG	MMA	MIG	MMA
Strømområde, A	15-300	15-250	15-300	15-300	15-400	15-400	15-400	15-400	15-550	15-550
Intermittens 100% 20°C, A/V	290/28,5	250/30,0	300/29,0	300/32,0	345/31,5	345/33,8	310/29,5	310/32,5	475/37,8	475/39,0
Intermittens maks. 20°C, A/%V					400/65/34,0	400/65/36,0	400/60/34,0	400/60/36,0	550/60/41,5	550/60/42,0
Intermittens 100% 40°C, A/V	220/25,0	220/28,8	270/27,5	270/30,8	300/29,0	300/32,0	280/28,0	280/31,2	430/35,5	430/37,2
Intermittens 60% 40°C, A/V	240/26,0	230/29,2			370/32,5	370/34,8	350/31,5	350/34,0	510/39,5	510/40,4
Intermittens maks. 40°C, A/%V	300/25/29,0	250/40/30,0	300/80/29,0	300/80/32,0	400/50/34,0	400/45/36,0	400/40/34,0	400/40/36,0	550/50/41,5	550/50/42,0
Tomgangsspænding, V	50-60		65-70		65-70		65-70		75-80	
² Anvendelsesklasse, C // S	S/CE // S/CE		S/CE // S/CE		S/CE // S/CE		S/CE // S/CE		S/CE // S/CE	
³ Beskyttelsesklasse	IP23S		IP23		IP23		IP23		IP23	
Normer, C	IEC60974-1, IEC60974-5, IEC60974-10 Cl. A									
Normer, S	IEC60974-1, IEC60974-10 Cl. A									
Dimensioner C (HxBxL), mm	700x260x735		700x260x735		700x260x735		700x260x735		700x260x735	
Dimensioner S (HxBxL), mm	454x260x735		454x260x735		454x260x735		454x260x735		454x260x735	
Vægt C / S, kg	36,9 / 26		53 / 36		52 / 35		53 / 36		53 / 36	

STRØMKILDE SIGMA Select	300 Boost				300 IAC Boost			
Netspænding ±10% (50-60Hz), V	3x208-380				3x380-440			
Minimum generatorstørrelse, kVA	16				25			
¹ Minimum kortslutningseffekt, MVA	1,7				3,75			
Sikring, A	20				16			
Netstrøm effektiv, A	19,5				10,6			
Netstrøm max., A	31,6				16,2			
Effekt 100%, kVA	7,1				7,0			
Effekt max., kVA	11,0				10,6			
Effekt tomgang, W	45				16			
Virkningsgrad, %	82				87			
Powerfaktor	0,95				0,95			
	MIG	MMA	MIG	MMA	MIG	MMA	MIG	MMA
Strømområde, A	15-300	15-250	15-300	15-250	15-300	15-300	15-300	15-300
Intermittens 100% 20°C, A/V	250/26,5		250/26,5		300/29,0	300/32,0	300/29,0	300/32,0
Intermittens maks. 20°C, A/%V	300/40/29,0		300/40/29,0					
Intermittens 100% 40°C, A/V	200/24,0	200/28,0	200/24,0	200/28,0	250/26,5	220/28,8	250/26,5	220/28,8
Intermittens 60% 40°C, A/V	210/24,5	210/28,4	210/24,5	210/28,4	270/27,5	250/30,0	270/27,5	250/30,0
Intermittens maks. 40°C, A/%V	300/25/29,0	250/35/30,0	300/25/29,0	250/35/30,0	300/35/29,0	300/30/32,0	300/35/29,0	300/30/32,0
Tomgangsspænding, V	50-60				70-75			
² Anvendelsesklasse, C // S	S/CE // S/CE				S/CE // S/CE			
³ Beskyttelsesklasse	IP23S				IP23			
Normer, C	IEC60974-1, IEC60974-5, IEC60974-10 Cl. A							
Normer, S	IEC60974-1, IEC60974-10 Cl. A							
Dimensioner C (HxBxL), mm	700x260x735				900x260x735			
Dimensioner S (HxBxL), mm	454x260x735				654x260x735			
Vægt C / S, kg	45 / 34				66 / 49			

1) Dette udstyr er i overensstemmelse med EN / IEC61000-3-12:2014 (/ 2011), forudsat at nettets kortslutningseffekt I_{sc} ved tilslutningsstedet er større end eller lig med de opgivne data i ovenstående skema. Installatøren eller brugeren af udstyret er ansvarlig for at sikre, evt. i samråd med forsyningsdistributoren, at udstyret er tilsluttet til en netforsyning med en kortslutningseffekt I_{sc} større end eller lig med de opgivne data i ovenstående skema.

2) S Maskiner opfylder de krav der stilles under anvendelse i områder med forøget risiko for elektrisk chok

3) Maskinen er godkendt til indendørs og udendørs brug i henhold til beskyttelsesklasse IP23 / IP23S.

IP23S: Maskinen kan opbevares men er ikke beregnet til at blive brugt udendørs under nedbør, medmindre den er afskærmet.

Tekniske data 2

STRØMKILDE SIGMA Select	400 Boost				400 IAC Boost			
Netspænding ±10% (50-60Hz), V	3x208-380		3x380-440		3x208-380		3x380-440	
Minimum generatorstørrelse, kVA	25		25		25		25	
¹⁾ Minimum kortslutningseffekt, MVA					4,0		4,0	
Sikring, A	25-50		25-50		25-50		25-50	
Netstrøm effektiv, A	22,0		11,7		24,8		11,8	
Netstrøm max., A	45,0		23,5		48,0		24,5	
Effekt 100%, kVA	8,3		8,1		8,5		8,5	
Effekt max., kVA	16,7		16,3		17,4		17,4	
Effekt tomgang, W	60		56		60		71	
Virkningsgrad, %	84		88		82		85	
Powerfaktor	0,96		0,95		0,96		0,96	
	MIG	MMA	MIG	MMA	MIG	MMA	MIG	MMA
Strømråde, A	15-400	15-400	15-400	15-400	15-400	15-400	15-400	15-400
Intermittens 100% 20°C, A/V	300/29,0	300/32,0	300/29,0	300/32,0	300/29,0	300/32,0	300/29,0	300/32,0
Intermittens maks. 20°C, A/%V	400/30/34,0	400/30/32,0	400/30/34,0	400/30/32,0	400/30/34,0	400/30/32,0	400/30/34,0	400/30/32,0
Intermittens 100% 40°C, A/V	250/26,5	220/28,8	250/26,5	220/28,8	250/26,5	220/28,8	250/26,5	220/28,8
Intermittens 60% 40°C, A/V	280/28,0	260/30,4	280/28,0	260/30,4	280/28,0	260/30,4	280/28,0	260/30,4
Intermittens maks. 40°C, A/%V	400/25/34,0	400/20/36,0	400/25/34,0	400/20/36,0	400/25/34,0	400/20/36,0	400/25/34,0	400/20/36,0
Tomgangsspænding, V	70-75				70-75			
²⁾ Anvendelsesklasse, C // S	S/CE // S/CE				S/CE // S/CE			
³⁾ Beskyttelsesklasse	IP23				IP23			
Normer, C	IEC60974-1, IEC60974-5, IEC60974-10 Cl. A				IEC60974-1, IEC60974-5, IEC60974-10 Cl. A			
Normer, S	IEC60974-1, IEC60974-10 Cl. A				IEC60974-1, IEC60974-10 Cl. A			
Dimensioner C (HxBxL), mm	900x260x735				900x260x735			
Dimensioner S (HxBxL), mm	654x260x735				654x260x735			
Vægt C / S, kg	66 / 49				67 / 50			

TRÅDBOKS MWF			
Trådfremføringshastighed, m/min	0,5-30,0		
Brændertilslutning	EURO		
Trådspolediameter, mm	300		
Trådrulle, kg	5-18		
Intermittens 100 % 40°C, A	430		
Intermittens 60% 40°C, A	500		
Intermittens maks. 40°C A/%	550/50		
³⁾ Beskyttelsesklasse	IP23		
Tråddiameter, mm	0,6-1,6		
Gastryk, MPa (bar)	0,6 (6,0)		
	MWF 30	MWF 32	MWF 33
Dimensioner (HxBxL), mm	413x310x750	457x260x672,5	457x260x672,5
Vægt, kg	11,6	14,0	14,0
Normer	IEC60974-5, IEC60974-10 CL. A		

KØLEMODUL MCU 1300	
Køleeffekt (1 l/min), W	1300
Køleeffekt (1,5 l/min), W	1600
Tankkapacitet, liter	5
Flow, bar - °C - l/min	3,0-60-1,5
Maks. tryk, bar	5
Normer	IEC60974-2, IEC60974-10 CL.A
Dimensioner (HxBxL), mm	207x260x680
Vægt, kg	20

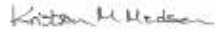
EU-OVERENSSTEMMELSESERKLÆRING	
	
MIGATRONIC A/S Aggersundvej 33 9690 Fjerritslev Danmark	
erklærer, at nedennævnte maskine	
Type:	SIGMA Select
er i overensstemmelse med bestemmelserne i direktiverne:	
	2014/35/EU 2014/30/EU 2011/65/EU
Europæiske standarder:	EN IEC60974-1:2018/A1:2019 EN IEC60974-2:2019 EN IEC60974-5:2019 EN / IEC60974-10:2014/A1:2015
Forordning:	2019/1784/EU
Udfærdiget i Fjerritslev 10.02.2021	
 Kristian M. Madsen CEO	

- 1) Dette udstyr er i overensstemmelse med EN / IEC61000-3-12:2014 (/ 2011), forudsat at nettets kortslutningseffekt S_{sc} ved tilslutningsstedet er større end eller lig med de opgivne data i ovenstående skema. Installatøren eller brugeren af udstyret er ansvarlig for at sikre, evt. i samråd med forsyningsdistributoren, at udstyret er tilsluttet til en netforsyning med en kortslutningseffekt S_{sc} større end eller lig med de opgivne data i ovenstående skema.
- 2) **S** Maskiner opfylder de krav der stilles under anvendelse i områder med forøget risiko for elektrisk chok
- 3) Maskinen er godkendt til indendørs og udendørs brug i henhold til beskyttelsesklasse IP23 / IP23S.
IP23S: Maskinen kan opbevares men er ikke beregnet til at blive brugt udendørs under nedbør, medmindre den er afskærmet.

Connection and start-up

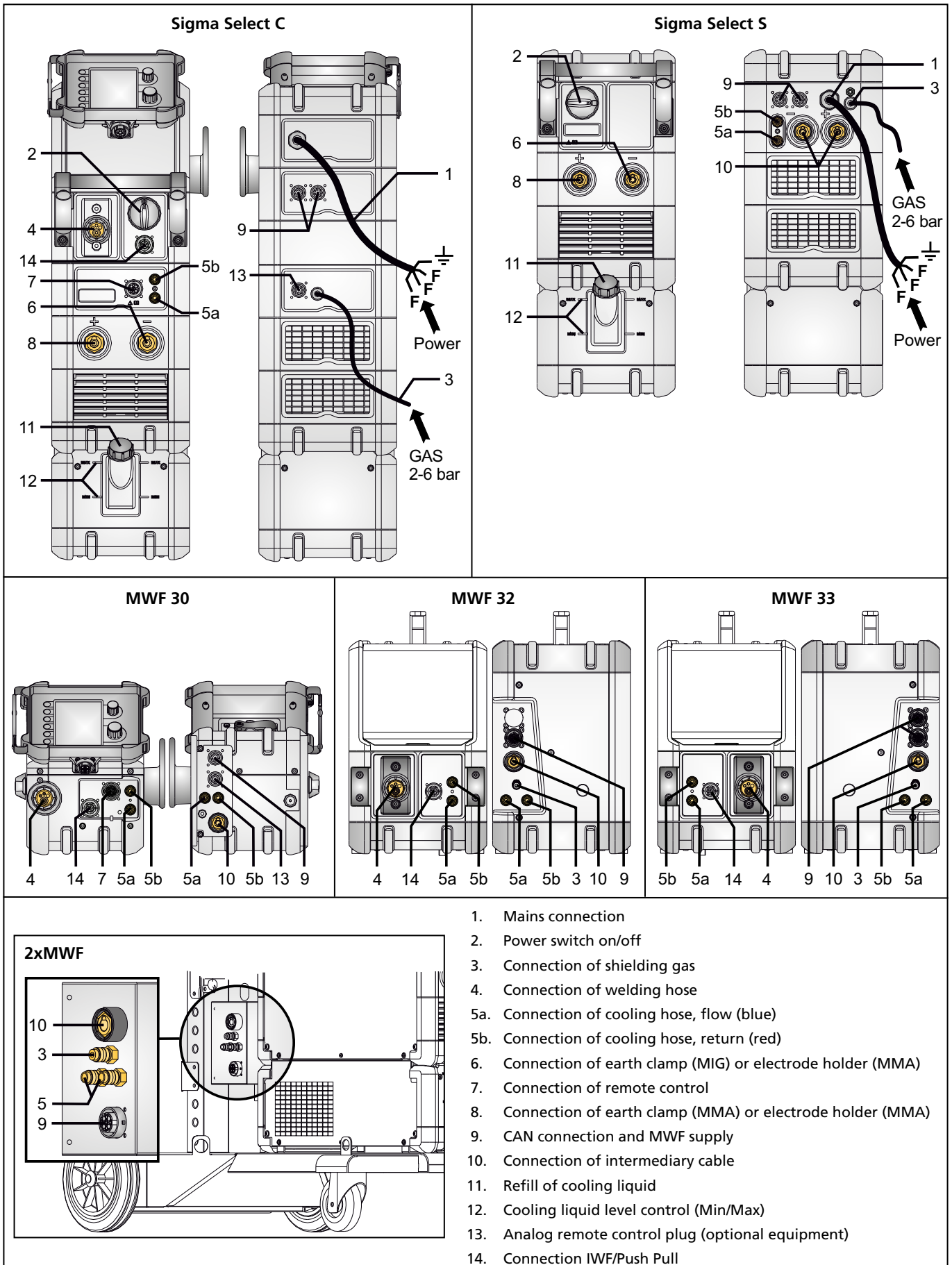

Connection and start-up



Warning

Read warning notice and instruction manual carefully prior to initial operation and save the information for later use.

Permissible installation

Mains connection

Connect the machine to the correct mains supply. Please read the type plate (U₁) on the rear side of the machine.

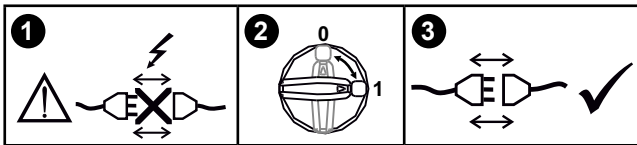
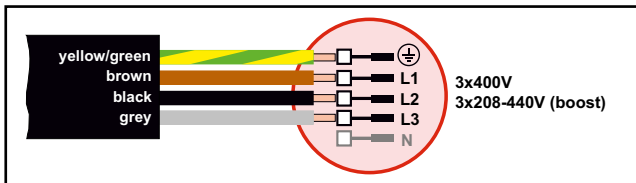

Voltage stabilisation kit

The power source is configurable with a voltage stabilisation kit as a safeguard against larger voltage variations, e.g. in case of generator use where the machine is connected to a separate power supply.

Connection of shielding gas

Connect the gas hose, which branches off from the back panel of the welding machine (3), to a gas supply with pressure regulator (2-6 bar). (Note: Some types of pressure regulators require an output pressure of more than 2 bar to function optimally). One/two gas cylinders can be mounted on the bottle carrier on the back of the trolley.

Gas consumption

Depending on the welding task, gas type and seam design, the gas consumption will vary in ranges from 6-7 l/min at low amperages (<25A) and up to 27 l/min at max. amperage.

Material consumption

Material consumption can be estimated by calculating welding time in minutes times wire feed speed (m/min) times weight per meter of the welding consumables in use.

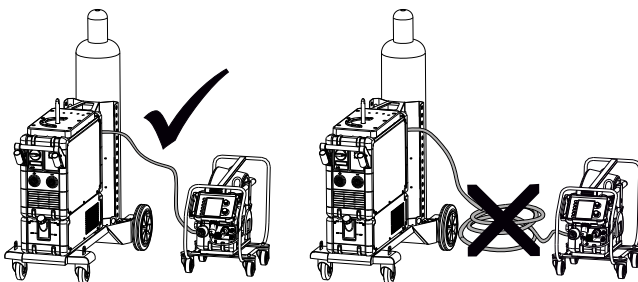

WARNING

When you activate the torch trigger, there is voltage applied to the welding wire and electrode.

Connection of welding hose

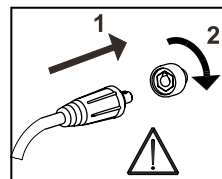
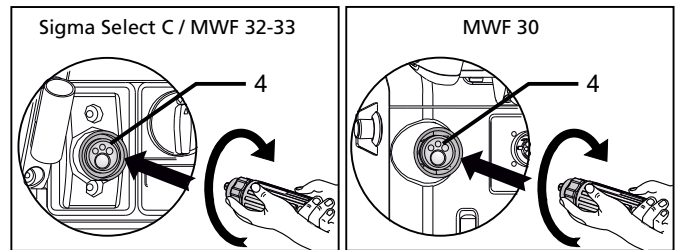

Important!

In order to avoid destruction of plugs and cables, good electric contact is required when connecting earth cables and welding hoses to the machine.

Connection of electrode holder for MMA

The electrode holder and earth cable are connected to plus connection (10) and minus connection (8). Observe the instructions from the electrode supplier when selecting polarity.

Recommended cable dimensions

Welding current	DC	PULSE
200 A	35 mm ²	35 mm ²
300 A	50 mm ²	70 mm ²
400 A	95 mm ² / 2x50 mm ²	95 mm ² / 2x50 mm ²
550 A	2x70 mm ²	2x70 mm ²

Welding process	Distance to work piece (a+b)	Total cable length in welding circuit (a+b+c)
MIG - IAC and pulse	10 m	20 m
MIG - non pulse	30 m	60 m

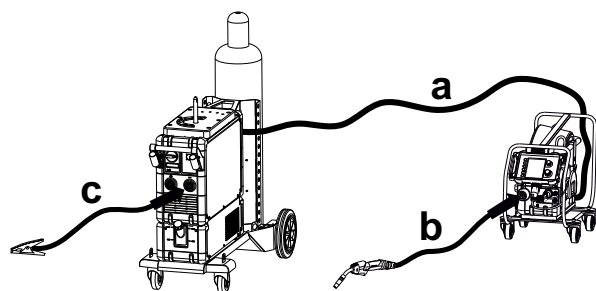

Adjustment of wire brake

The wire brake must be adjusted so as to stop the wire reel before the welding wire runs over the edge of the reel. The brake force depends on the weight of the wire reel and the wire feed speed. Factory setting is 15kg.

Adjustment:

- Dismount the control knob by placing a thin screw driver behind the knob and then pull it out.
- Adjust the wire brake by fastening or loosening the self-locking nut on the axle of the wire hub.
- Remount the control knob.

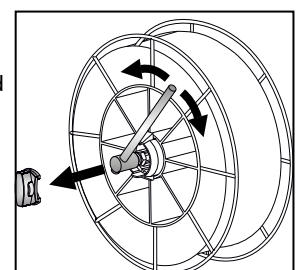

Connection and start-up

Lift instructions

The lifting points must be used (please see figure) when lifting the machine or the MWF unit. The machine must not be lifted with mounted gas bottle.

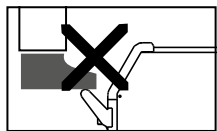
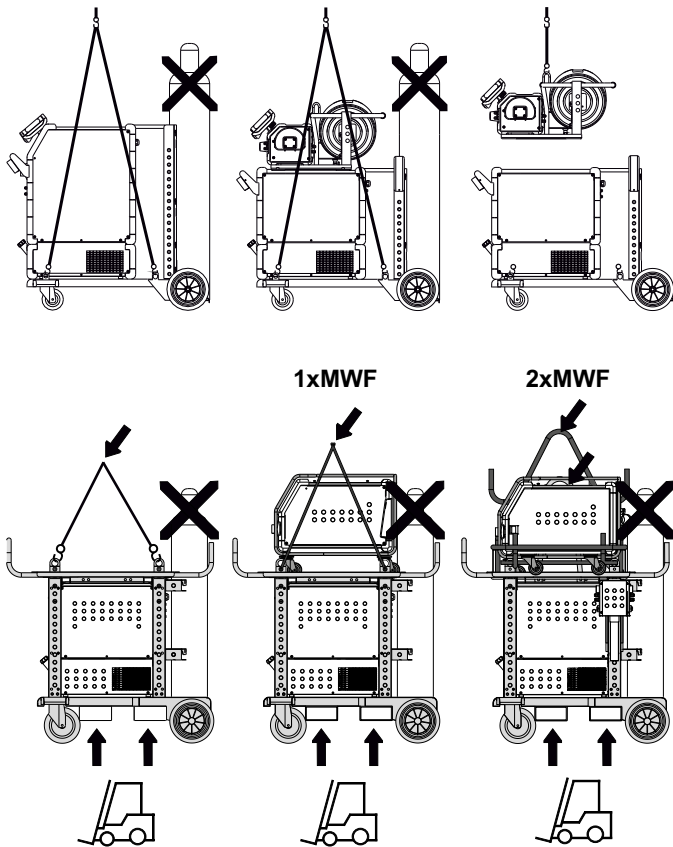

Do not lift the machine by the handle.
Do not step on the handle.

Mounting the remote control

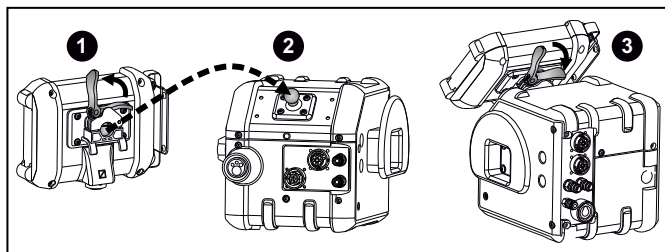

MWF 30 cable coiling

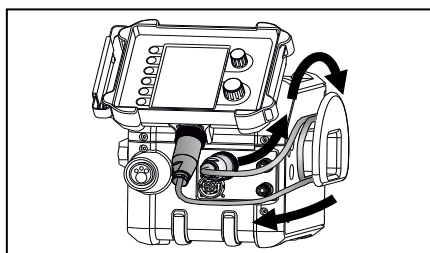

MCU ventilation

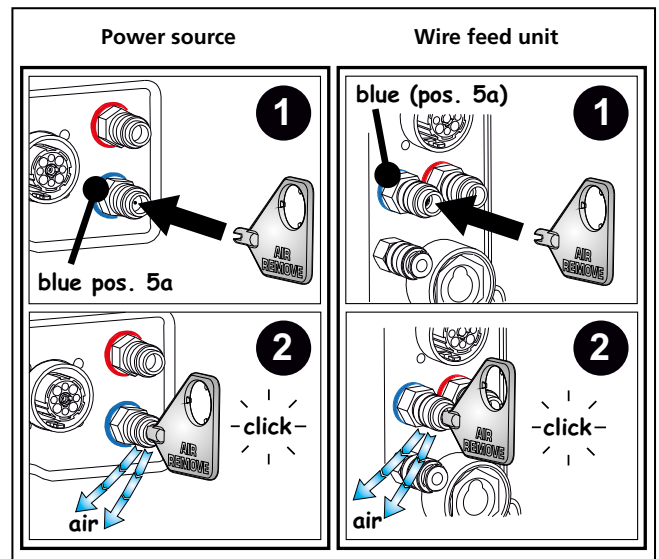

MWF lock-turn function

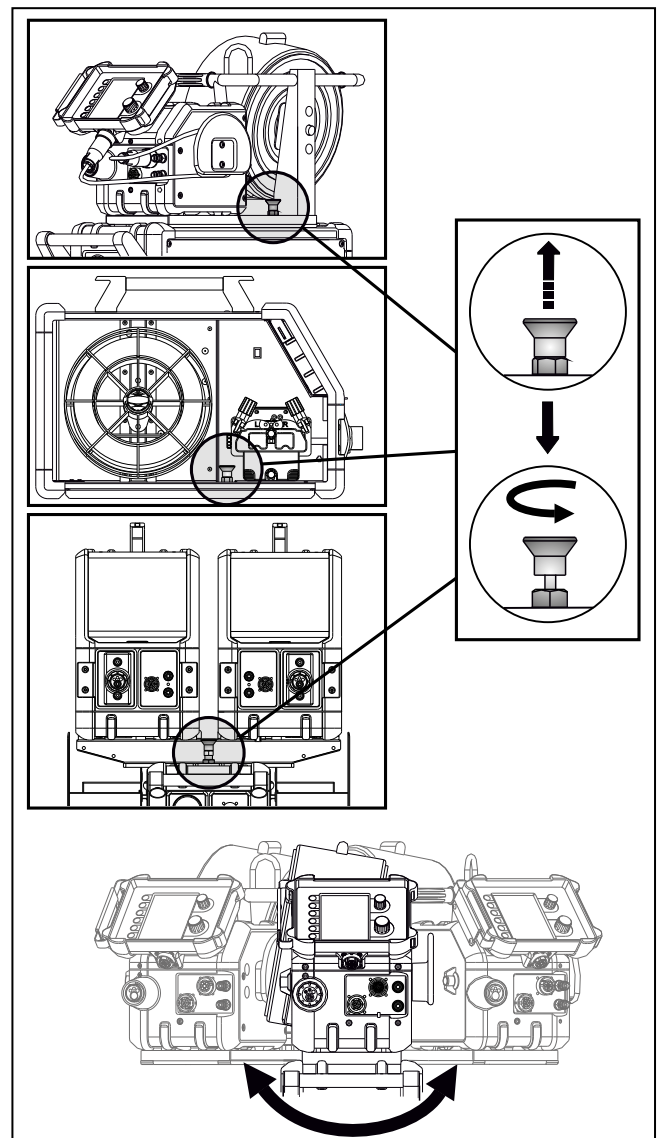

Connection and start-up

Assembly of parts in wire feed unit

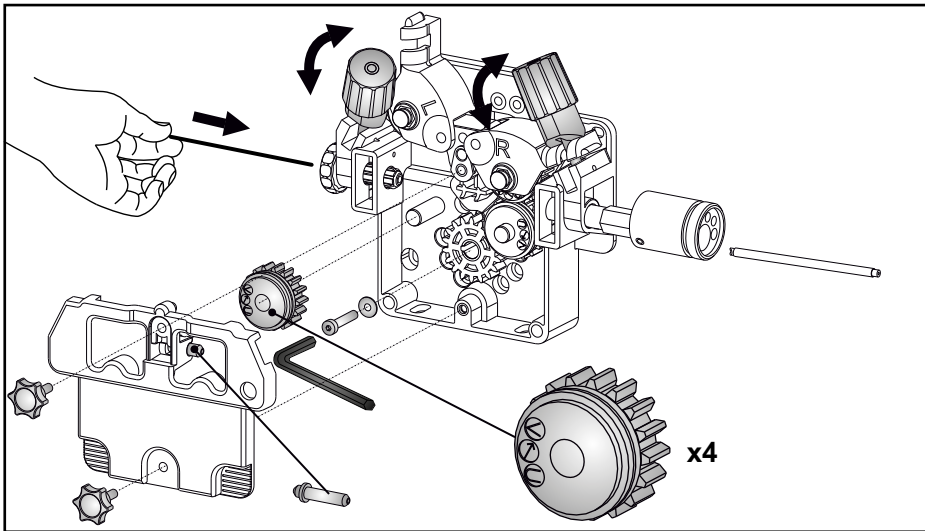

The pressure of the thumbscrew is adjusted to allow the wire feed roll just to slide on the wire when this is stopped at the contact tip

Wire inching forward/backward

When idling, wire inching can be activated by pressing one of the keys or activated at the robot interface, if the MWF30 unit is used in a robot setup.

Wire inching

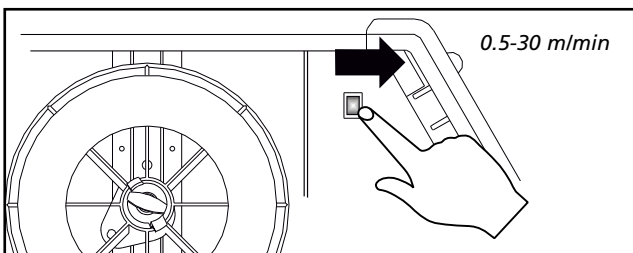

Wire inching MWF 30

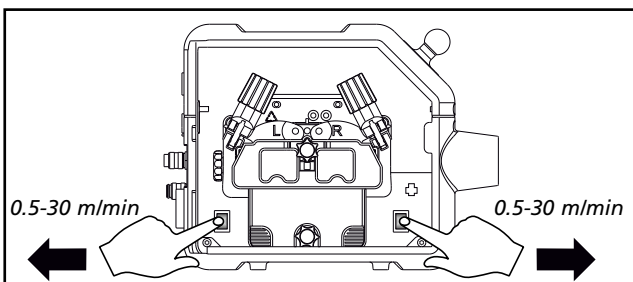

Wire inching Graphical

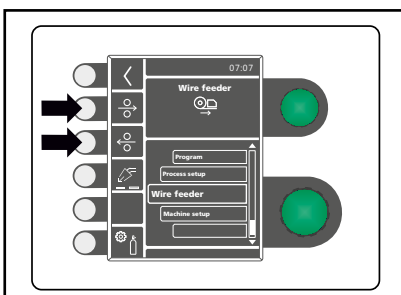

Software update

- Insert the SD-card
- Turn on the machine
- Wait until the unit indicates that the update is complete
- Turn off the machine and remove the SD card
- The machine is now ready for use

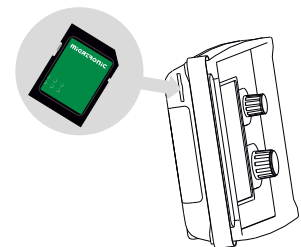

New software will be loaded into power source and all connected units.

The software can be downloaded from <http://migatron.com> to an SD card. The file system of the SD card must be formatted to FAT32.

IMPORTANT:

Save the software in the //MIGA_SW/SIGMA/ file structure.

Licence SW

If you purchase additional licences for programs or special functions, load the MigaLic.dat files like the software packages. Note! Create a backup of the files.

The MigaLic.txt file contains information about licence number and licences saved on SD card.

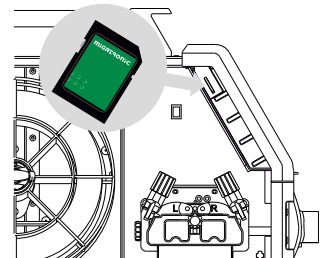

BASIC - Special functions

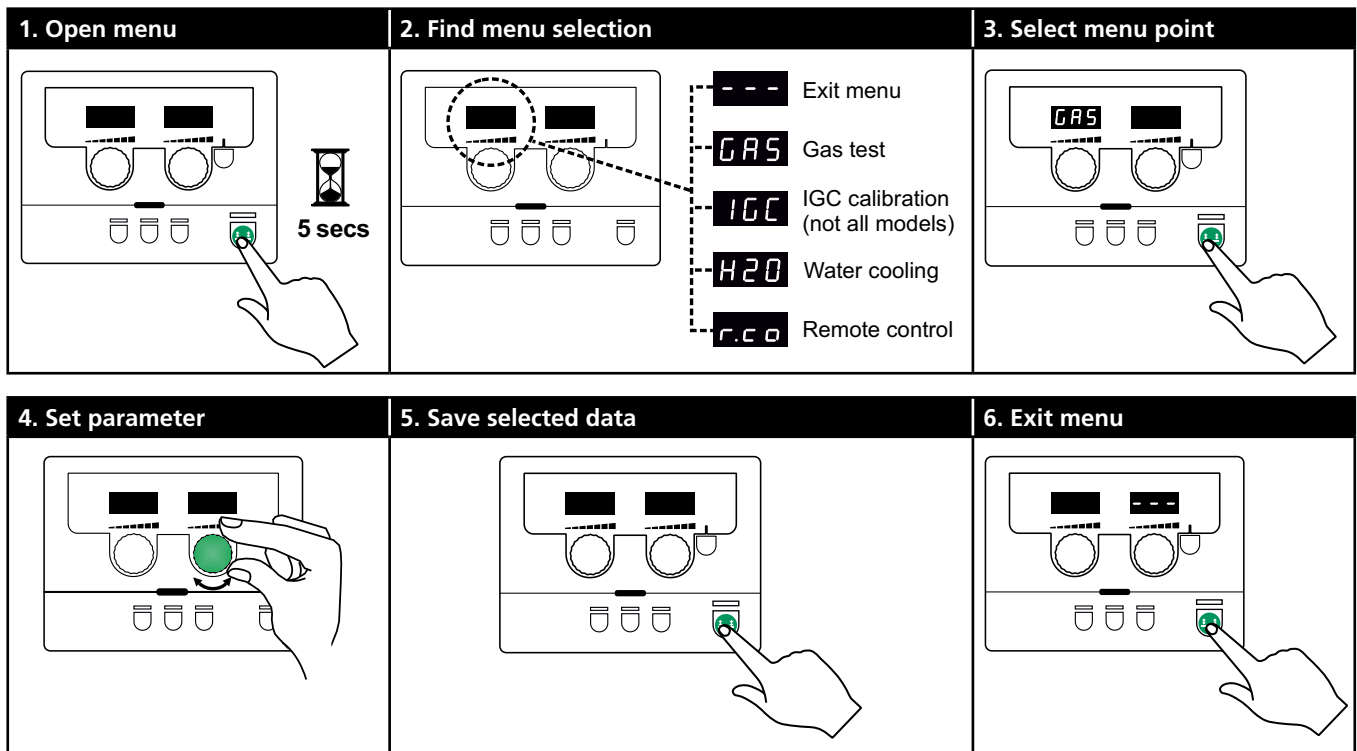

Parameters and menu selection

Press and hold the -key to open the user menu. Turn the left control knob until the desired menu is displayed. Use the right control knob to alter settings displayed in the right display. Press the -key briefly to activate functions, such as gas test.

Functions and parameters in the user menu:

--- **GAS** **IGC** **H2O** **r.c.o**

--- Press the -key to exit the menu

GAS GAS test
Press the -key to open and close the gas valve. If an IGC kit is installed, it is possible to adjust the gas flow with the right control knob.

IGC IGC calibration
Visible only if IGC kit is installed.
Press the -key to start IGC calibration.

H2O Water cooling
Visible only if water cooling unit is installed.

0: Water cooling OFF
1: Water cooling ON

r.c.o Setting remote control
Use the right control knob to change the following settings:

0: Disabled
1: Dialog torch (item no. 80100402)
2: Analogue remote control (item no. 78815029)

BASIC - Special functions

Configuration of external control

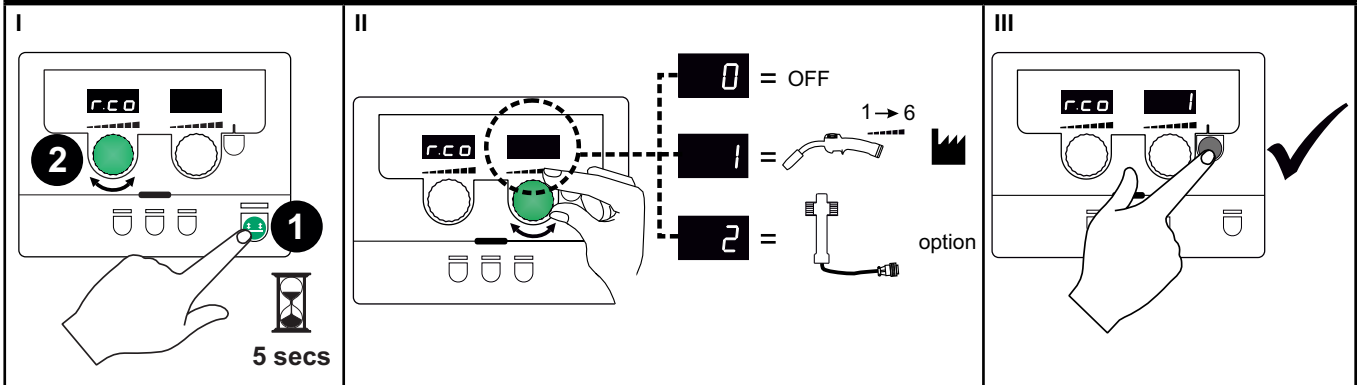

Lock function /

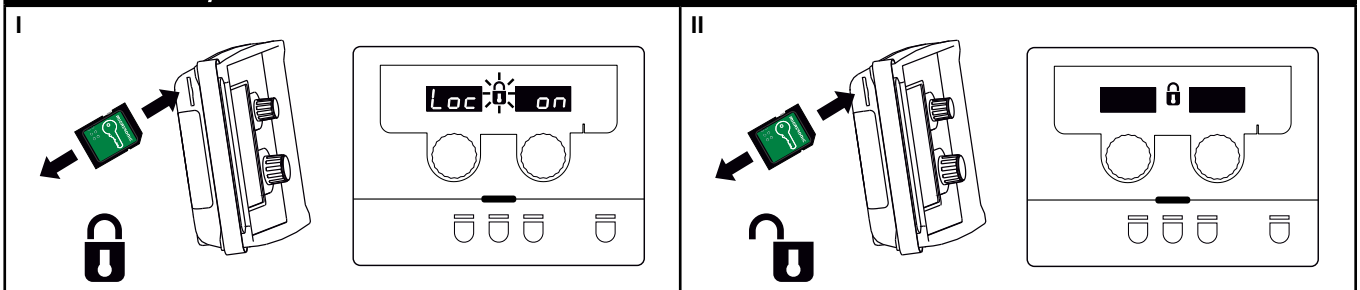

Calibration of gas flow (not all models)

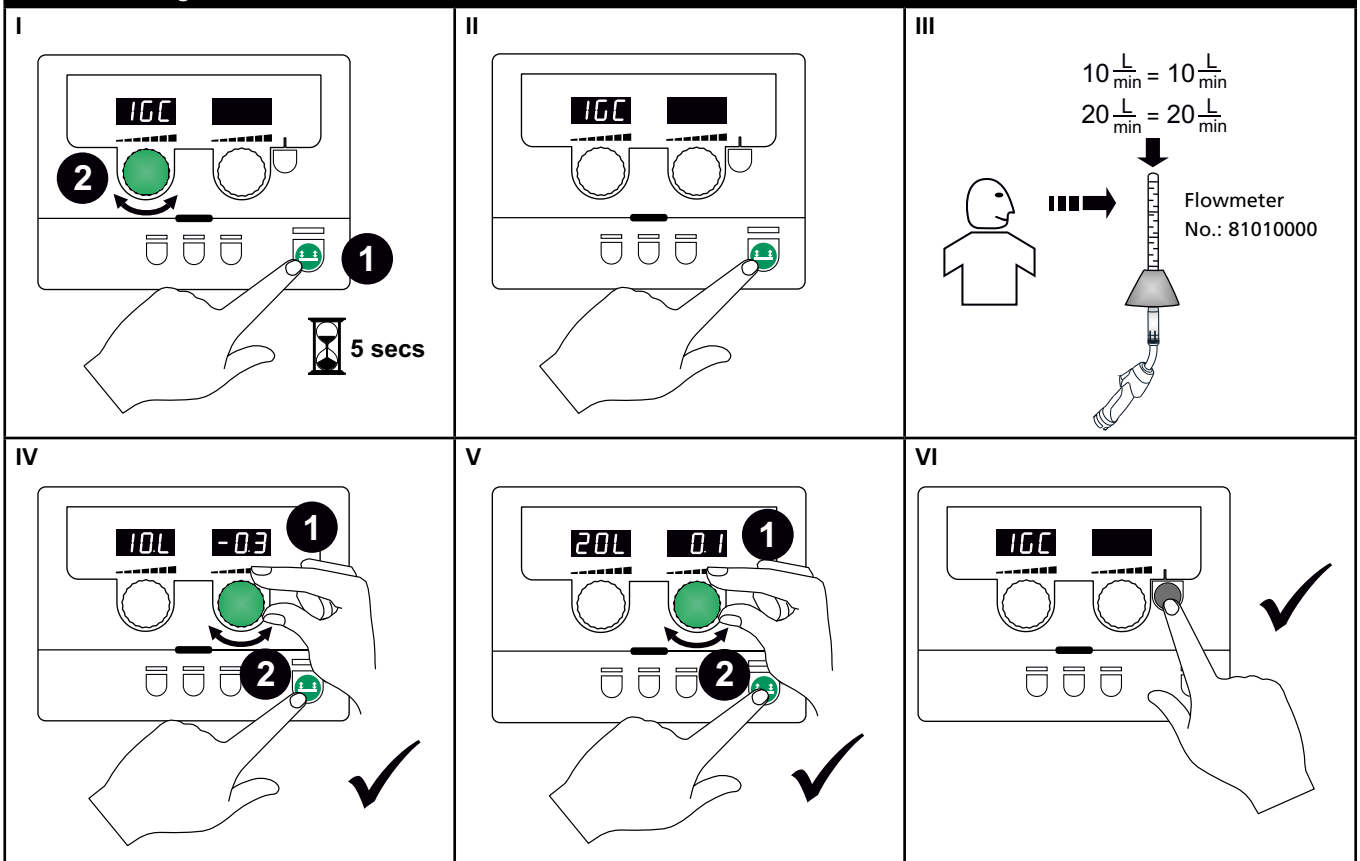

BASIC - Special functions

Display of software versions/licence number

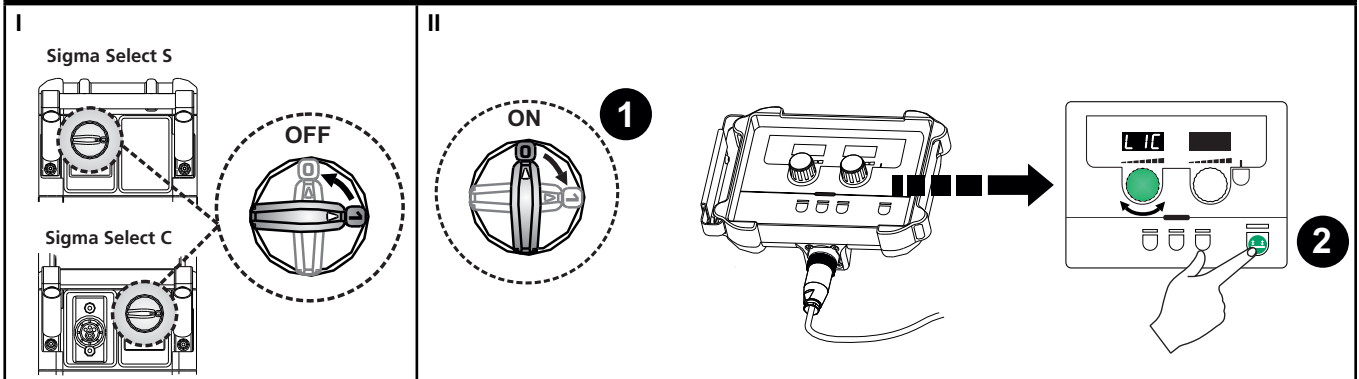

1. Licence number

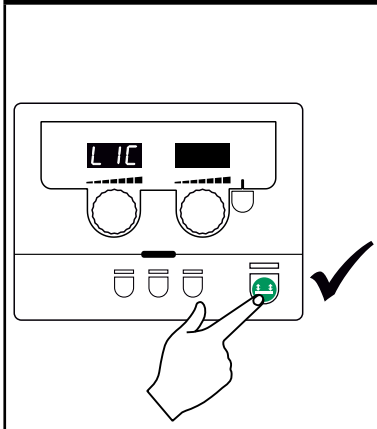

2. See licence no. (12 digits)

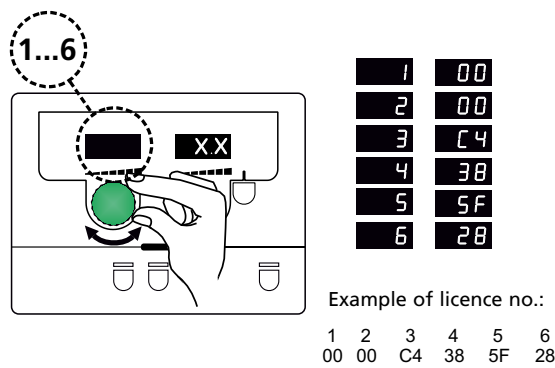

3. Return to SW versions

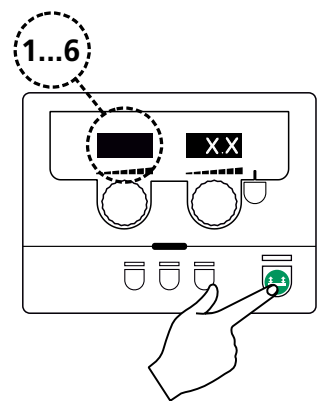

4. Select SW

- Basic remote **1**
- Welding package **2**
- Main controller **3**
- "-" **4**
- "-" **5**
- Wire feeder **6**
- Wire feeder **7**
- Arc controller **8**
- "-" **9**
- "-" **10**
- "-" **11**
- "-" **12**
- "-" **13**
- "-" **14**
- "-" **15**
- "-" **16**
- Water controller **17**
- Smart Torch **18**

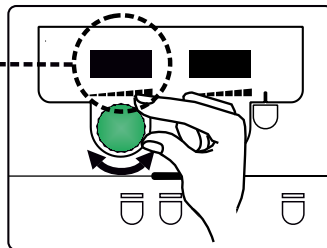

5. Exit menu

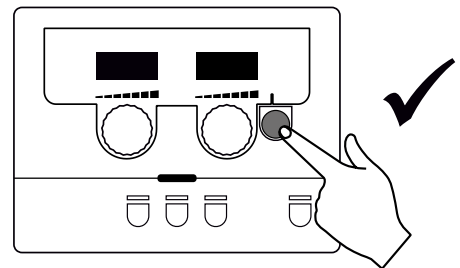



"-" not supported

BASIC - Error handling

Error code	Cause and solution
E20-00 E20-02 E21-00 E21-06 E21-08	There is no software present in the control unit Download software to the SD card, insert the SD card into the control unit and turn on the machine. Replace the SD card, if necessary.
E20-01 E21-01	The SD card is not formatted Format the SD card in a PC as FAT and download software to the SD card. Replace the SD card, if necessary.
E20-03 E21-02	The SD card has several files of the same name Delete files on the SD card and reload software.
E20-04	The control unit has tried to load more data than there is room for in the memory Reinsert the SD card or replace the SD card. If this does not solve the problem, contact Migatron Service.
E20-05 E20-06	Software on the SD card is locked for another type of control unit Use an SD card with software that matches your type of control unit.
E20-07	The internal copy protection does not allow access to the micro-processor Reinsert the SD card into the machine or contact Migatron Service.
E20-08 E20-09 E21-05	The control unit is defective Contact MIGATRONIC Service
E20-10 E21-07	The loaded file is defective Reinsert the SD card or replace the SD card.
E21-03 E21-04	The welding program package does not match this control unit Use an SD card with software that matches your type of control unit.
Err GAS	Gas error Check the gas supply. Cancel the gas fault by briefly pressing any key.
E02-04	CAN communication error Check intermediary cable/plug
E11-20	Current sensor error 1. Check the current sensor 2. Contact MIGATRONIC service

Fault symbols

 **Temperature fault**
The indicator is switched on, when the power source is overheated. Leave the machine on until the built-in fan has cooled it down.

 **Current fault**
The indicator flashes when start current or welding current is higher than permitted by the welding machine's efficiency. Make sure that wire speed/current and voltage are set correctly.

 **Fault symbols**
The indicator flashes when other types of errors occur. At the same time an error code is shown in the display.



Selected error codes

 **E11 15 Mains supply fault**
The indicator is displayed, when the mains voltage is too high. Connect the welding machine to 400V AC, +/-15% 50-60Hz.

 **Err H2O Torch cooling fault**
Cooling fault is indicated on machines in case of insufficient circulation of the cooling liquid due to faulty connection, defective parts or choking. Check that the cooling hoses are correctly connected, top up the water tank and check welding hose and branches.

If the coolant viscosity is reduced due to low temperatures, the Migatron standard coolant must be exchanged with 99290515 BTC-20 NF coolant, which is characterised by its extremely low conductance and high viscosity down to temperatures at -17°C. Flush the system before adding new type of coolant.

The cooling fault is cancelled by pressing shortly on the -key pad.

 **Err GAS Gas control fault (IGC)**
Gas fault exists due to a too low or high gas flow. Make sure that the pressure on the gas flow is higher than 2 bar and less than 6 bar, corresponding to 5 l/min and 27 l/min.
The fault is disconnected by adjusting the manual gas flow to 27 l/min.
The gas fault is reset by a short pressure on the -key pad.

Wire feed fault
 or 

The indicator is displayed, if the wire feed motor is overloaded.
The wire feed motor or magnet valve may be defective.

Other types of faults

If other fault symbols are shown in the display, the machine shall be switched off and then on to dispose of the symbol. If the fault symbol is shown repeatedly, repair of the power source is required.

Contact your distributor with information of the fault.

When separate units are connected, the following error codes can be displayed:

 **E07 04** is displayed when the communication between the power source and the connected unit(s) is lost.

 **E07 05** is displayed when controlling the motor is not running properly.

 **E07 06** is displayed when the motor is overloaded.

GRAPHICAL - Special functions

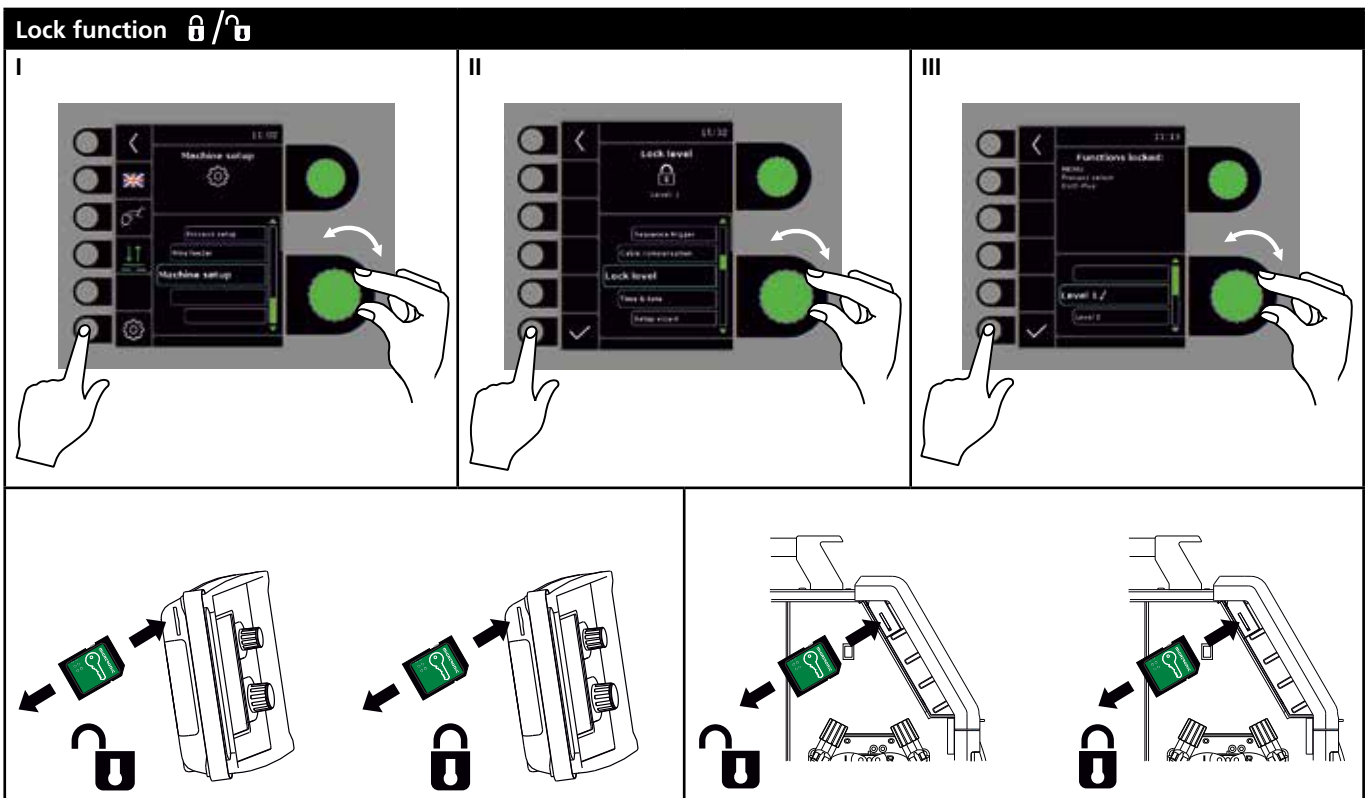
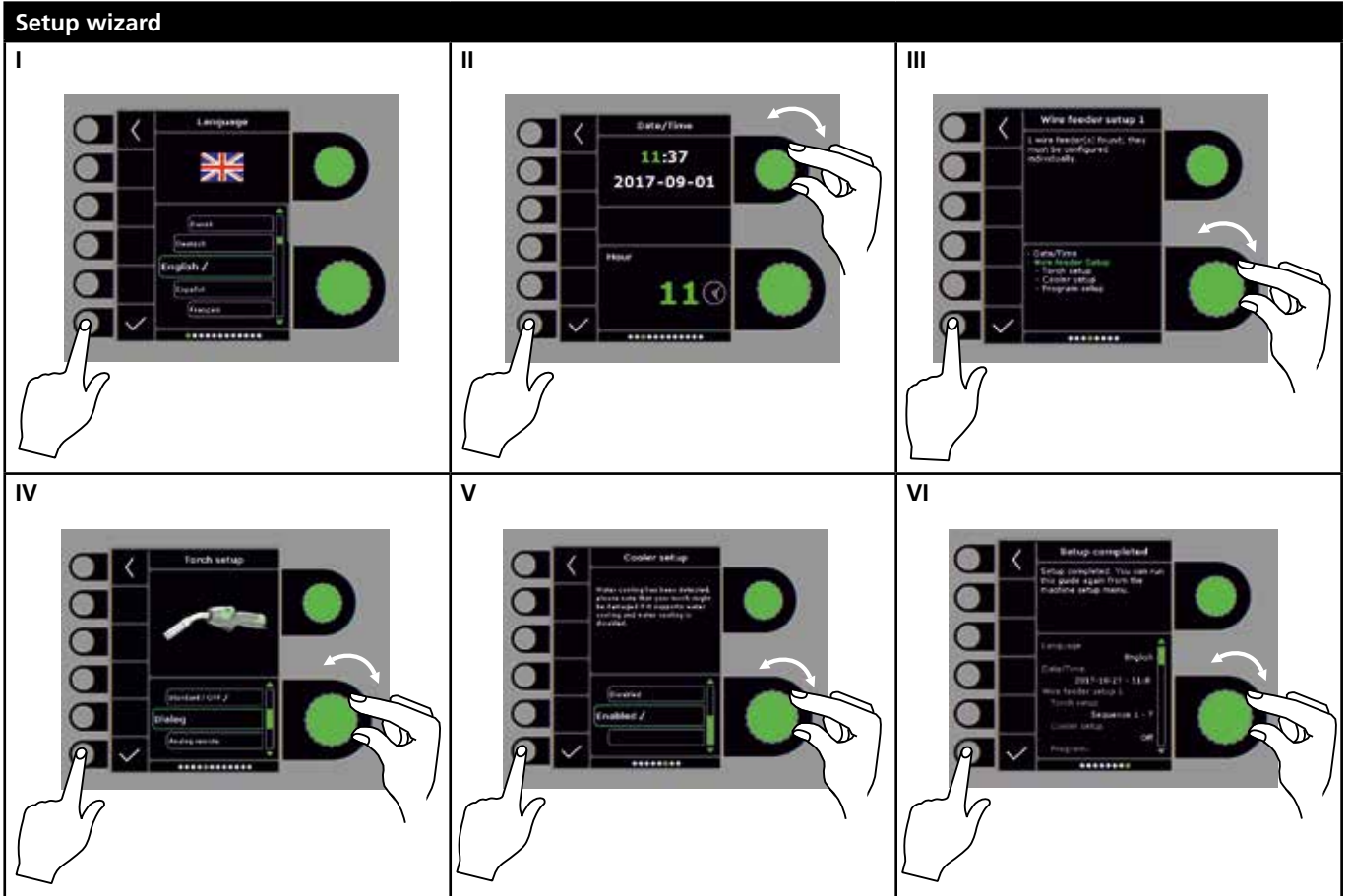

GRAPHICAL - Special functions

Software / Licenses

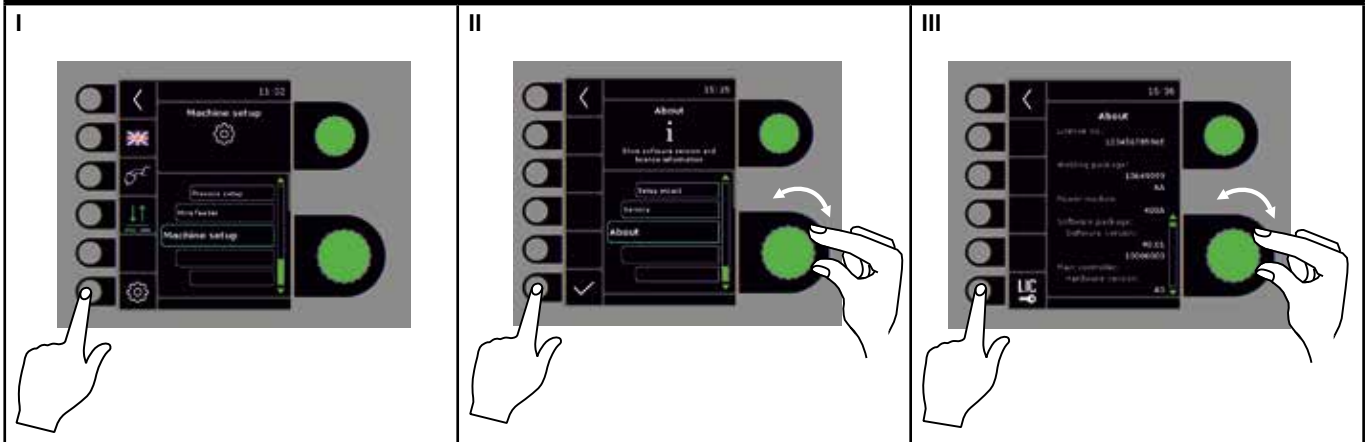

Cable compensation (calibration of resistance in welding hose)

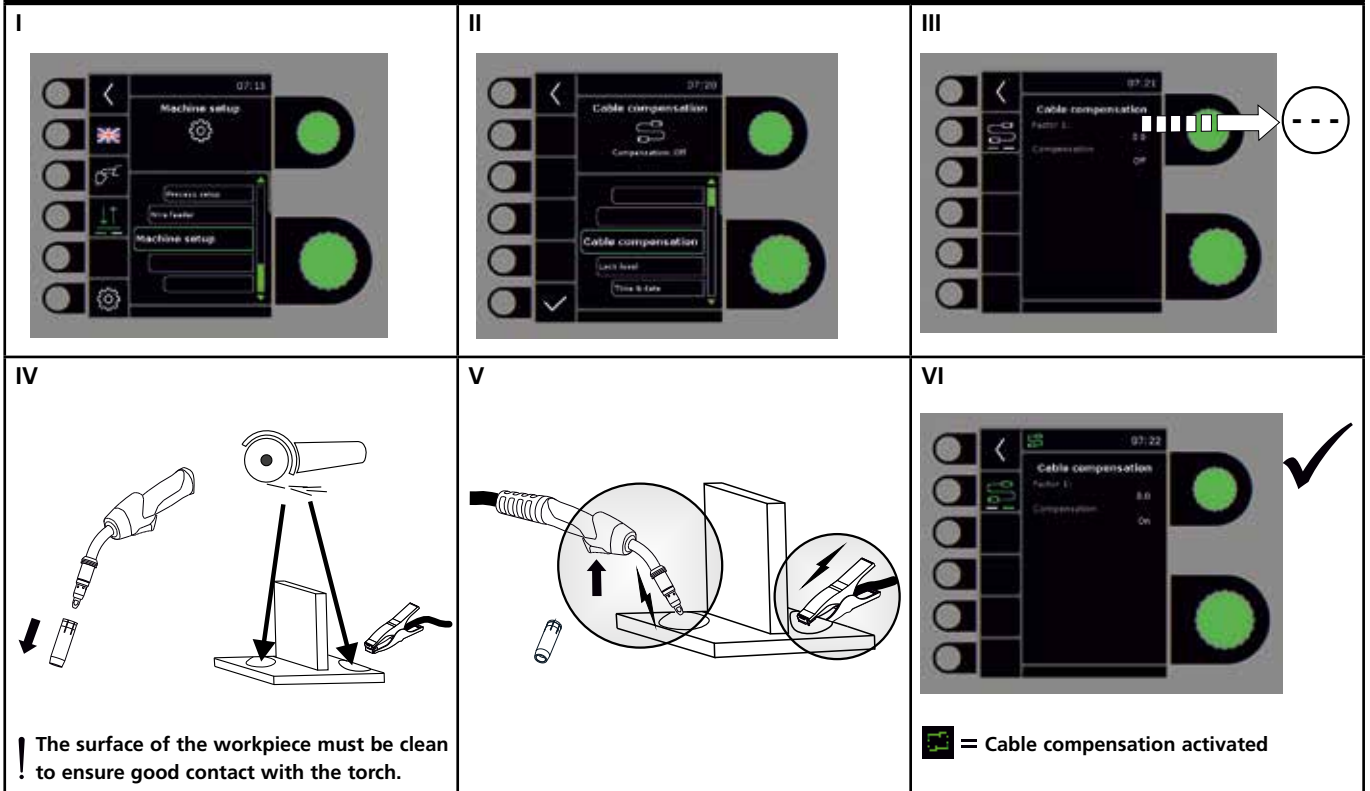

Torch setup

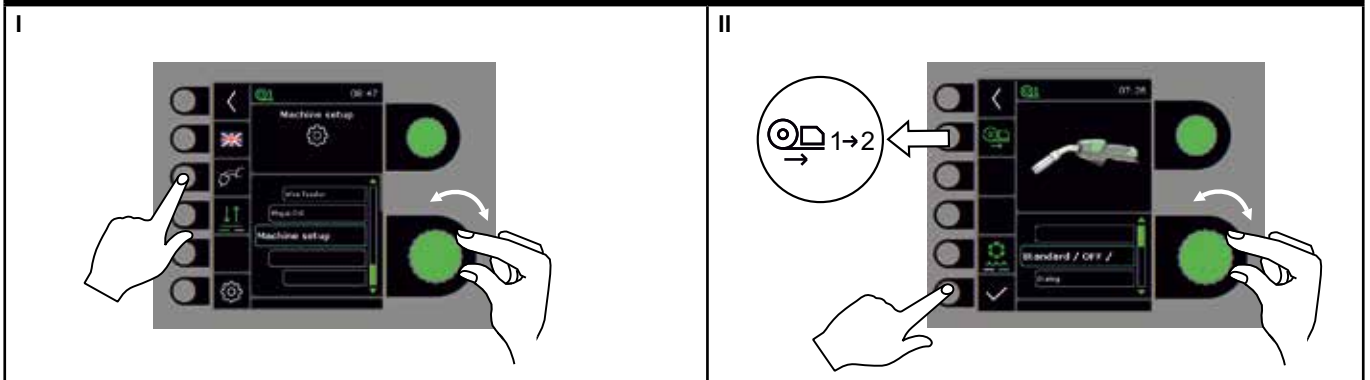

GRAPHICAL - Special functions

Calibration of gas flow (not all models)

I

II

III

IV

V

GRAPHICAL - Error handling

SIGMA Select has a sophisticated built-in self-protection system. The machine automatically stops the gas supply, interrupts the welding current and stops the wire feeding in case of an error.

Selected errors:

Torch cooling fault

Cooling fault is indicated on machines in case of insufficient circulation of the cooling liquid due to faulty connection, defective parts or choking. Check that the cooling hoses are correctly connected, top up the water tank and check welding hose and branches.

If the coolant viscosity is reduced due to low temperatures, the Migatronic standard coolant must be exchanged with 99290515 BTC-20 NF coolant, which is characterised by its extremely low conductance and high viscosity down to temperatures at -17°C. Flush the system before adding new type of coolant.

The cooling fault is cancelled by pressing shortly on the ✓-key pad.



Gas control fault (IGC)

Gas fault exists due to a too low or high gas flow.

Make sure that the pressure on the gas flow is higher than 2 bar and less than 6 bar, corresponding to 5 l/min and 27 l/min.

The fault is disconnected by adjusting the manual gas flow to 27 l/min. The gas fault is reset by a short pressure on the ✓-key pad.

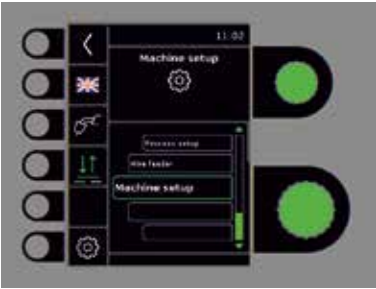
Note: it is important that the stated gas supply can be maintained during welding.

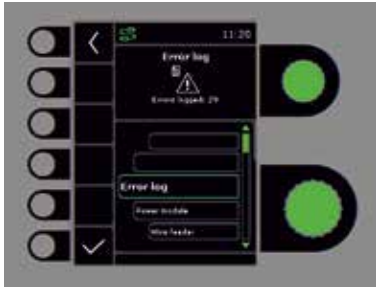
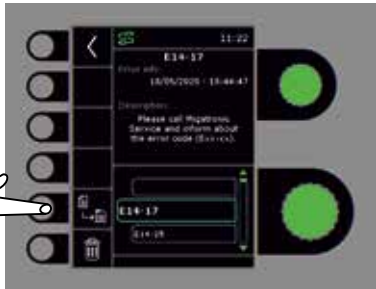
Error log		
<p>I</p>  <p>A screenshot of the machine's control panel showing the 'Machine setup' menu. The screen displays various settings options like 'Process setup', 'Wire feeder', and 'Machine setup'.</p>	<p>II</p>  <p>A screenshot of the machine's control panel showing the 'Service' menu. The screen displays options like 'Time & date', 'Error code', 'Service', and 'About'.</p>	<p>III</p>  <p>A screenshot of the machine's control panel showing the 'Error log' menu. The screen displays 'Error type: 29' and 'Error log'.</p>
<p>IV</p> <p>Error log All errors are saved in the machine error log in the menu Service. The error log can be distributed, when inserting a SD-card and pressing the following key: The error log is now saved at the SD-card. The error log can be reset when pressing the key pad with the trash bin.</p>	 <p>A screenshot of the machine's control panel showing the 'Error log' menu with a list of error entries. A hand icon points to the trash bin icon at the bottom of the screen, which is used to reset the error log.</p>	

Technical data 1

POWER SOURCE	300		300 IAC		400		400 IAC		550	
Mains voltage $\pm 15\%$ (50-60Hz), V	3x400		3x400		3x400		3x400		3x400	
Minimum generator size, kVA	16		19		27		29		40	
¹ Minimum short-circuit power, MVA	3.7		4.3		6.0		6.0		9.5	
Fuse, A	16		16		20		20		35	
Mains current effective, A	11.0		16.0		17.5		16.5		27.2	
Mains current max., A	15.4		18.3		26.0		28.2		39.2	
Power 100%, kVA	9.0		11.1		12.1		11.4		18.9	
Power max., kVA	10.7		12.7		18.0		19.5		27.1	
Power open circuit, W	11		13		12		13		12	
Efficiency, %	87		85		89		85		90	
Power factor	0.90		0.90		0.90		0.90		0.90	
	MIG	MMA	MIG	MMA	MIG	MMA	MIG	MMA	MIG	MMA
Current range, A	15-300	15-250	15-300	15-300	15-400	15-400	15-400	15-400	15-550	15-550
Duty cycle 100% 20°C, A	290/28.5	250/30.0	300/29.0	300/32.0	345/31.5	345/33.8	310/29.5	310/32.5	475/37.8	475/39.0
Duty cycle max. 20°C, A/%V					400/65/34.0	400/65/36.0	400/60/34.0	400/60/36.0	550/60/41.5	550/60/42.0
Duty cycle 100% 40°C, A/V	220/25.0	220/28.8	270/27.5	270/30.8	300/29.0	300/32.0	280/28.0	280/31.2	430/35.5	430/37.2
Duty cycle 60% 40°C, A/V	240/26.0	230/29.2			370/32.5	370/34.8	350/31.5	350/34.0	510/39.5	510/40.4
Duty cycle max. 40°C, A/%V	300/25/29.0	250/40/30.0	300/80/29.0	300/80/32.0	400/50/34.0	400/45/36.0	400/40/34.0	400/40/36.0	550/50/41.5	550/50/42.0
Open circuit voltage, V	50-60		65-70		65-70		65-70		75-80	
² Sphere of application, C // S	S/CE // S/CE		S/CE // S/CE		S/CE // S/CE		S/CE // S/CE		S/CE // S/CE	
³ Protection class	IP23S		IP23		IP23		IP23		IP23	
Standards, C	IEC60974-1. IEC60974-5. IEC60974-10 Cl. A									
Standards, S	IEC60974-1. IEC60974-10 Cl. A									
Dimensions C (HxWxL), mm	700x260x735		700x260x735		700x260x735		700x260x735		700x260x735	
Dimensions S (HxWxL), mm	454x260x735		454x260x735		454x260x735		454x260x735		454x260x735	
Weight C / S, kg	36.9 / 26		53 / 36		52 / 35		53 / 36		53 / 36	

POWER SOURCE	300 Boost				300 IAC Boost			
Mains voltage $\pm 10\%$ (50-60Hz), V	3x208-380		3x380-440		3x208-380		3x380-440	
Minimum generator size, kVA	16		16		4.0		25	
¹ Minimum short-circuit power, MVA	1.7		3.75				4.0	
Fuse, A	20		16		25-50		20-50	
Mains current effective, A	19.5		10.6		22.5		11.9	
Mains current max., A	31.6		16.2		33.0		15.2	
Power 100%, kVA	7.1		7.0		8.4		8.3	
Power max., kVA	11.0		10.6		11.1		10.6	
Power open circuit, W	45		16		60		56	
Efficiency, %	82		87		85		88	
Power factor	0.95		0.95		0.96		0.95	
	MIG	MMA	MIG	MMA	MIG	MMA	MIG	MMA
Current range, A	15-300	15-250	15-300	15-250	15-300	15-300	15-300	15-300
Duty cycle 100% 20°C, A	250/26.5		250/26.5		300/29.0	300/32.0	300/29.0	300/32.0
Duty cycle max. 20°C, A/%V	300/40/29.0		300/40/29.0					
Duty cycle 100% 40°C, A/V	200/24.0	200/28.0	200/24.0	200/28.0	250/26.5	220/28.8	250/26.5	220/28.8
Duty cycle 60% 40°C, A/V	210/24.5	210/28.4	210/24.5	210/28.4	270/27.5	250/30.0	270/27.5	250/30.0
Duty cycle max. 40°C, A/%V	300/25/29.0	250/35/30.0	300/25/29.0	250/35/30.0	300/35/29.0	300/30/32.0	300/35/29.0	300/30/32.0
Open circuit voltage, V	50-60				70-75			
² Sphere of application, C // S	S/CE // S/CE				S/CE // S/CE			
³ Protection class	IP23S				IP23			
Standards, C	IEC60974-1. IEC60974-5. IEC60974-10 Cl. A				IEC60974-1. IEC60974-5. IEC60974-10 Cl. A			
Standards, S	IEC60974-1. IEC60974-10 Cl. A				IEC60974-1. IEC60974-10 Cl. A			
Dimensions C (HxWxL), mm	700x260x735				900x260x735			
Dimensions S (HxWxL), mm	454x260x735				654x260x735			
Weight C / S, kg	45 / 34				66 / 49			

- This equipment complies with EN / IEC61000-3-12:2014 (/ 2011) provided that the short-circuit power S_{sc} of the grid at the interface point is greater than or equal to the stated data in the abovementioned table. It is the responsibility of the installer or user of the equipment to ensure, by consultation with the distribution network operator if necessary, that the equipment is connected only to a supply with a short-circuit power S_{sc} greater than or equal to the stated data in the abovementioned table.
- S** This machine meets the demand made for machines which are to operate in areas with increased hazard of electric shocks.
- The machine is designed for indoor and outdoor use according to protection class IP23 / IP23S.
IP23S: The machine may be stored but is not intended to be used outside during precipitation unless sheltered

Technical data 2

POWER SOURCE	400 Boost				400 IAC Boost			
Mains voltage $\pm 10\%$ (50-60Hz), V	3x208-380		3x380-440		3x208-380		3x380-440	
Minimum generator size, kVA	25		25		25		25	
¹⁾ Minimum short-circuit power, MVA					4.0		4.0	
Fuse, A	25-50		25-50		25-50		25-50	
Mains current effective, A	22.0		11.7		24.8		11.8	
Mains current max., A	45.0		23.5		48.0		24.5	
Power 100%, kVA	8.3		8.1		8.5		8.5	
Power max., kVA	16.7		16.3		17.4		17.4	
Power open circuit, W	60		56		60		71	
Efficiency, %	84		88		82		85	
Power factor	0.96		0.95		0.96		0.96	
	MIG	MMA	MIG	MMA	MIG	MMA	MIG	MMA
Current range, A	15-400	15-400	15-400	15-400	15-400	15-400	15-400	15-400
Duty cycle 100% 20°C, A	300/29.0	300/32.0	300/29.0	300/32.0	300/29.0	300/32.0	300/29.0	300/32.0
Duty cycle max. 20°C, A/%V	400/30/34.0	400/30/32.0	400/30/34.0	400/30/32.0	400/30/34.0	400/30/32.0	400/30/34.0	400/30/32.0
Duty cycle 100% 40°C, A/V	250/26.5	220/28.8	250/26.5	220/28.8	250/26.5	220/28.8	250/26.5	220/28.8
Duty cycle 60% 40°C, A/V	280/28.0	260/30.4	280/28.0	260/30.4	280/28.0	260/30.4	280/28.0	260/30.4
Duty cycle max. 40°C, A/%V	400/25/34.0	400/20/36.0	400/25/34.0	400/20/36.0	400/25/34.0	400/20/36.0	400/25/34.0	400/20/36.0
Open circuit voltage, V	70-75				70-75			
²⁾ Sphere of application, C // S	S/CE // S/CE				S/CE // S/CE			
³⁾ Protection class	IP23				IP23			
Standards, C	IEC60974-1. IEC60974-5. IEC60974-10 Cl. A				IEC60974-1. IEC60974-5. IEC60974-10 Cl. A			
Standards, S	IEC60974-1. IEC60974-10 Cl. A				IEC60974-1. IEC60974-10 Cl. A			
Dimensions C (HxWxL), mm	900x260x735				900x260x735			
Dimensions S (HxWxL), mm	654x260x735				654x260x735			
Weight C / S, kg	66 / 49				67 / 50			

WIRE FEED UNIT MWF			
Wire feed speed, m/min	0.5-30.0		
Torch connection	EURO		
Wire-reel diameter, mm	300		
Wire spool, kg	5-18		
Duty cycle 100 % 40°C, A	430		
Duty cycle 60% 40°C, A	500		
Duty cycle max. 40°C, A/%	550/50		
³⁾ Protection class	IP23		
Wire diameter, mm	0.6-1.6		
Gas pressure, MPa (bar)	0.6 (6.0)		
	MWF 30	MWF 32	MWF 33
Dimensions (HxWxL), mm	413x310x750	457x260x672.5	457x260x672.5
Weight, kg	11.6	14.0	14.0
Standards	IEC60974-5, IEC60974-10 CL. A		

COOLING UNIT MCU 1300	
Cooling efficiency (1 l/min), W	1300
Cooling efficiency (1.5 l/min), W	1600
Tank capacity, liter	5
Flow, bar - °C - l/min	3.0-60-1.5
Pressure max., bar	5
Standards	IEC60974-2. IEC60974-10 CL.A
Dimension s (HxWxL), mm	207x260x680
Weight	20

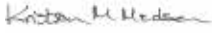
EC DECLARATION OF CONFORMITY	
	
MIGATRONIC A/S Aggersundvej 33 9690 Fjerritslev Denmark	
hereby declare that our machine as stated below	
Type:	SIGMA SELECT
conforms to directives:	2014/35/EU 2014/30/EU 2011/65/EU
European standards:	EN IEC60974-1:2018/A1:2019 EN IEC60974-2:2019 EN IEC60974-5:2019 EN / IEC60974-10:2014/A1:2015
Regulation:	2019/1784/EU
Issued in Fjerritslev 10.02.2021	
 Kristian M. Madsen CEO	

- 1) This equipment complies with EN / IEC61000-3-12:2014 (/ 2011) provided that the short-circuit power S_{sc} of the grid at the interface point is greater than or equal to the stated data in the abovementioned table. It is the responsibility of the installer or user of the equipment to ensure, by consultation with the distribution network operator if necessary, that the equipment is connected only to a supply with a short-circuit power S_{sc} greater than or equal to the stated data in the abovementioned table.
- 2) **S** This machine meets the demand made for machines which are to operate in areas with increased hazard of electric shocks.
- 3) The machine is designed for indoor and outdoor use according to protection class IP23 / IP23S.
IP23S: The machine may be stored but is not intended to be used outside during precipitation unless sheltered

Anschluss und Inbetriebnahme

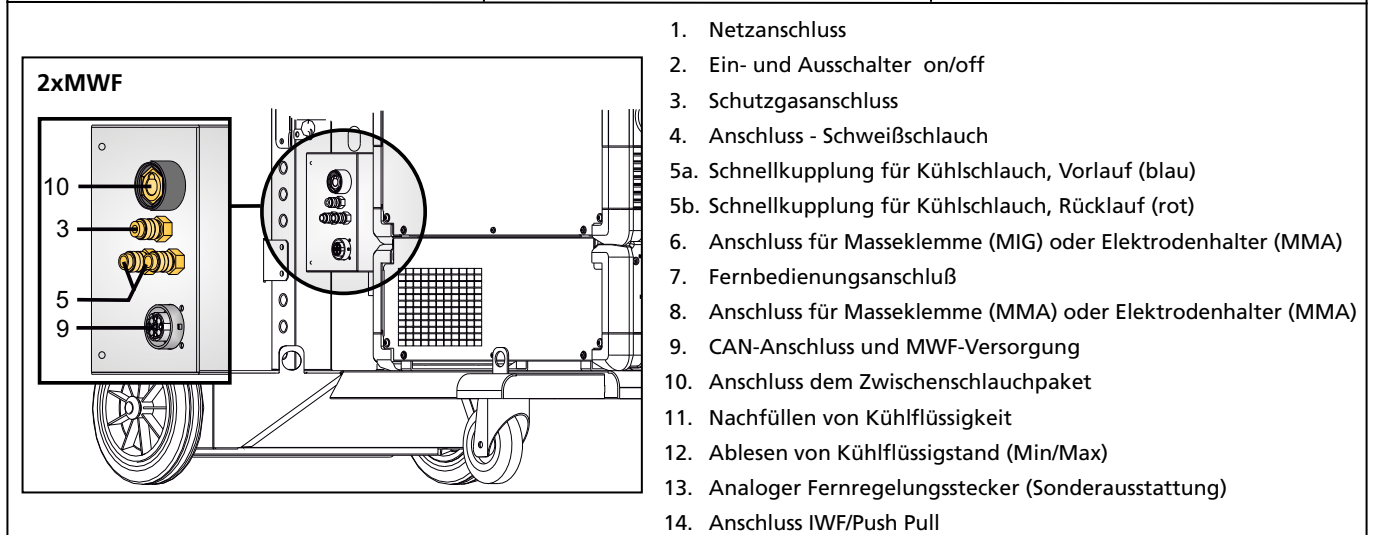
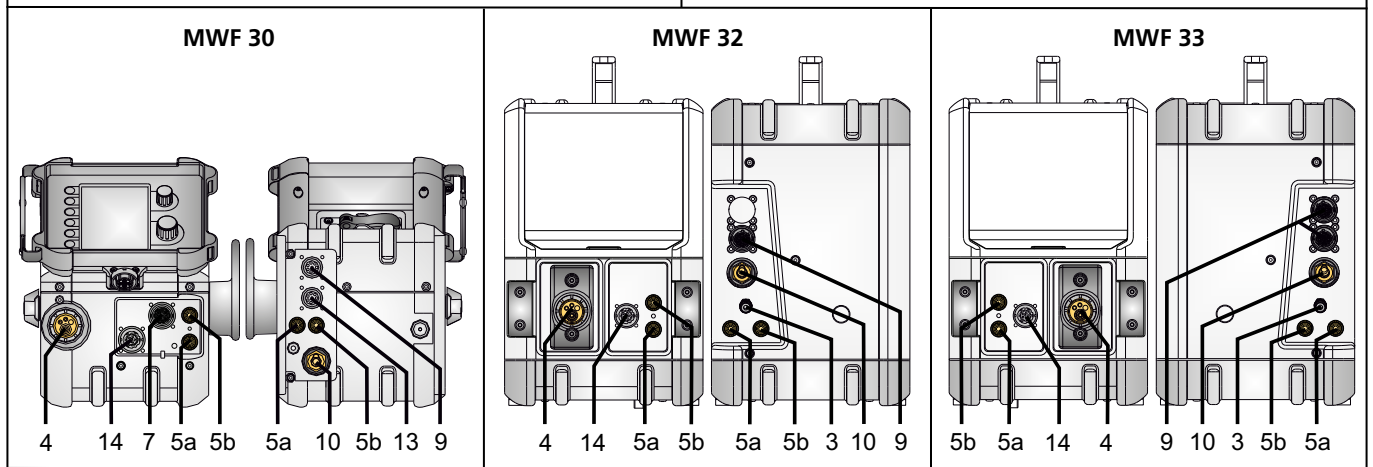
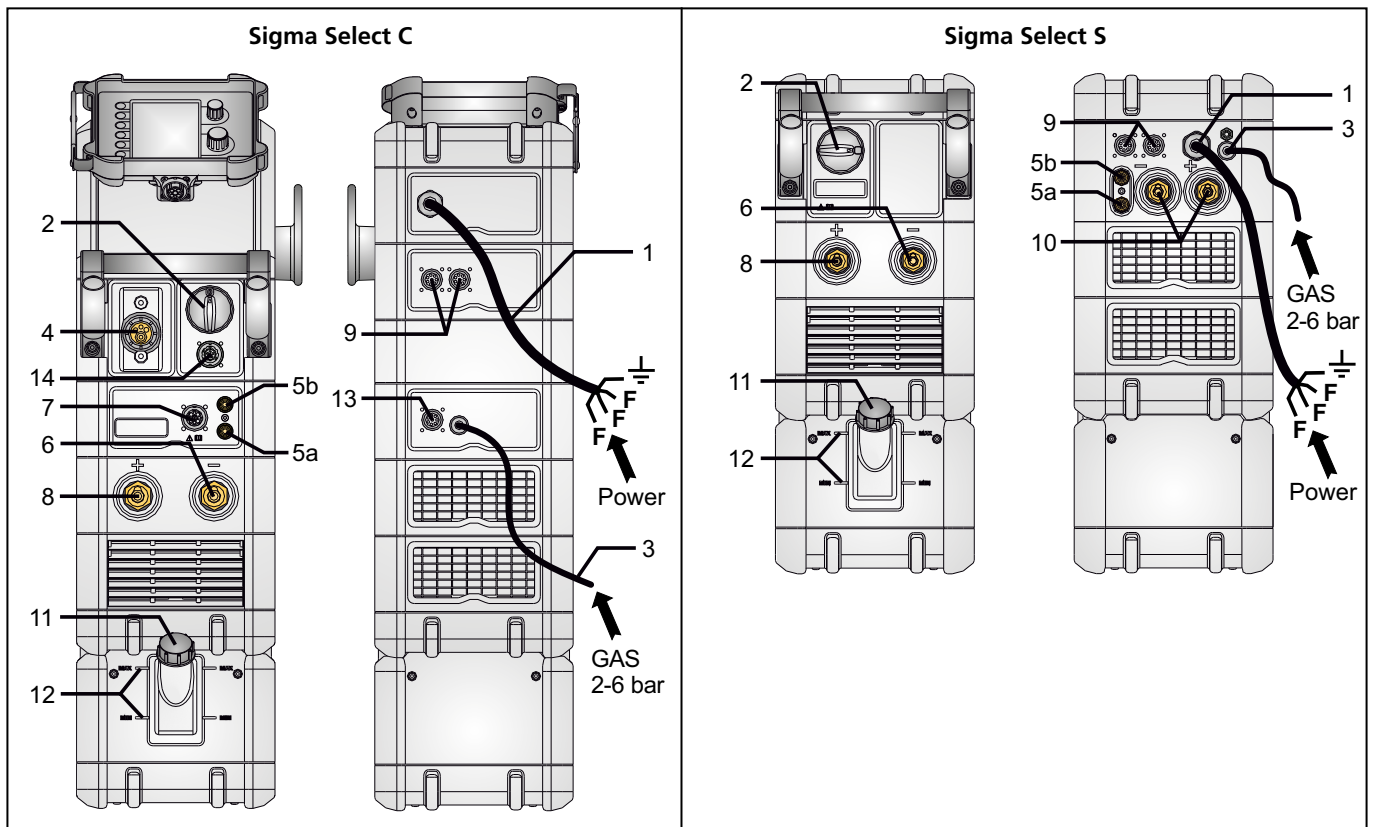

Anschluss und Inbetriebnahme



Warnung

Lesen Sie die Warnhinweise und Betriebsanleitung sorgfältig vor der Inbetriebnahme und speichern Sie die Information für den späteren Gebrauch.

Zulässige Installation

Netzanschluss

Die Maschine soll an eine Netzspannung angekuppelt werden, die mit den Angaben auf dem Typenschild (U1) hinter die Maschine übereinstimmt.

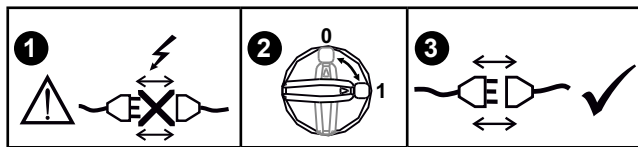
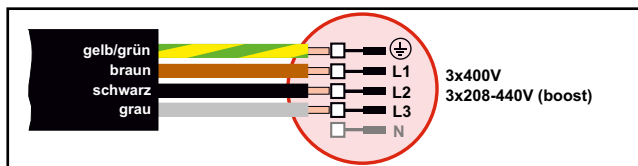

Spannungsstabilisierungs-Kit

Die Stromquelle lässt sich mit einem Spannungsstabilisierungs-Kit zum Schutz gegen höhere Spannungsschwankungen konfigurieren, z.B. beim Generatorbetrieb, wo die Maschine an eine separate Stromversorgung angeschlossen ist.

Schutzgasanschluss

Den Gasschlauch an der Rückseite der Maschine (3) an eine Gasversorgung mit Druckregler (2-6 bar) anschließen. (NB! Einige Druckreglertypen fordern einen höheren Ausgangsdruck als 2 bar um optimal zu funktionieren). Eine Gasflasche/ zwei Gasflaschen können hinter dem Wagen fixiert werden.

Gasverbrauch

Abhängig von der Schweißaufgabe, der Gasart und der Schweißnaht variiert der Gasverbrauch in Bereichen von 6 bis 7 l/min bei niedrigen Stromstärken (<25 A) bis zu 27 l/min bei max. Strom.

Materialverbrauch

Materialverbrauch kann berechnet werden, wenn die Schweißzeit in Minuten mit der Drahtfördergeschwindigkeit (m/min) und Gewicht pro Meter der aktuellen Zusatzmaterialien multipliziert werden.

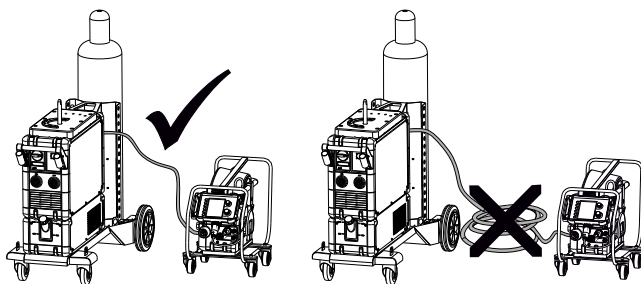

WARNUNG

Bei Betätigung des Brenntasters liegt Spannung an dem Schweißdraht und der Elektrode an.

Anschluß des Schweißschlauchs

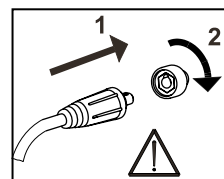
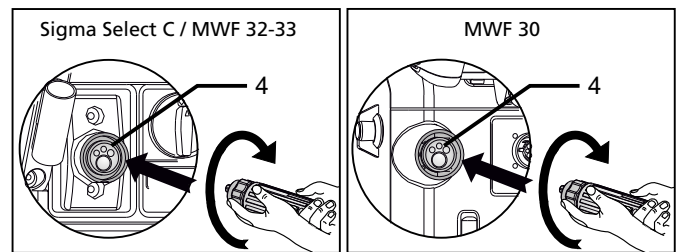

Wichtig!

Achten Sie auf festen Sitz der Anschlüsse von Massekabel und Schweißschlauch. Die Stecker und Kabel können sonst beschädigt werden.

Anschluss des Elektrodenhalters für MMA

Elektrodenhalter und Massekabel werden an Pluspol (10) und Minuspol (8) angeschlossen. Die zu wählende Polarität ist von den zu verwendenden Elektroden abhängig und wird gemäß den Herstellerangaben (siehe Elektroden-Verpackung) gewählt.

Empfohlene Kabelgrößen

Schweißstrom	DC	PULS
200 A	35 mm ²	35 mm ²
300 A	50 mm ²	70 mm ²
400 A	95 mm ² / 2x50 mm ²	95 mm ² / 2x50 mm ²
550 A	2x70 mm ²	2x70 mm ²

Schweißprozess	Abstand zum Werkstück (a+b)	Gesamtkabellänge im Schweißkreislauf (a+b+c)
MIG - IAC und Puls	10 m	20 m
MIG - ohne Puls	30 m	60 m

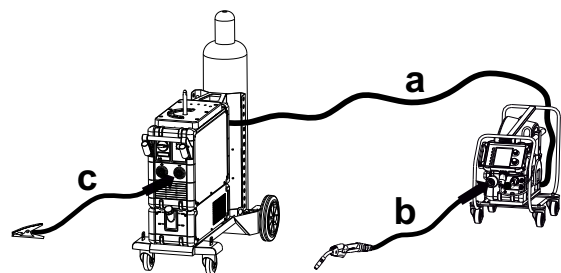

Justierung der Drahtbremse

Die Bremse so fest einstellen, dass die Draht-rolle stoppt, ehe der Schweißdraht über die Korb-spule springt. Die Bremskraft ist vom Gewicht der Drahtrolle und der Drahtfördergeschwindigkeit abhängig. Werkeinstellung = 15kg.

Justierung:

- Der Drehknopf lässt sich mittels eines dünnen Schraubendrehers herausdrücken und abmontieren.
- Die Drahtbremse durch Festspannen bzw. Lockern der Gegenmutter auf der Achse der Drahtnabe justieren.
- Den Drehknopf wieder montieren.

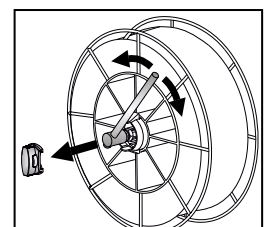

Anschluss und Inbetriebnahme

Hebeanweisung

Wenn die Maschine oder die MWF-Einheit angehoben werden soll, muss an den der Abbildung gezeigten Hebepunkten angesetzt werden. Die Maschine darf nicht mit montierter Gasflasche angehoben werden!

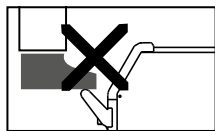
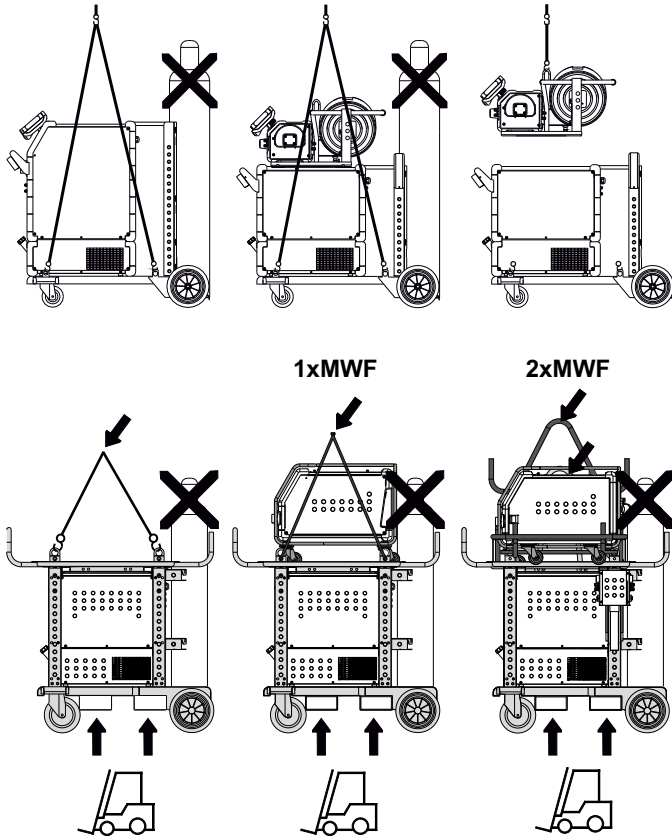

Die Maschine nicht am Handgriff anheben. Nicht auf den Handgriff treten.

Montage des Steuerpanels

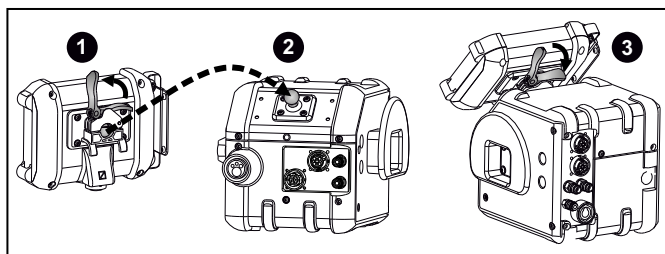

Kabelauffrollvorrichtung MWF 30

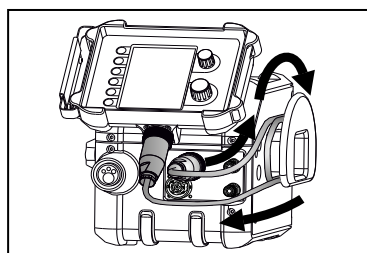

MCU Lüftung

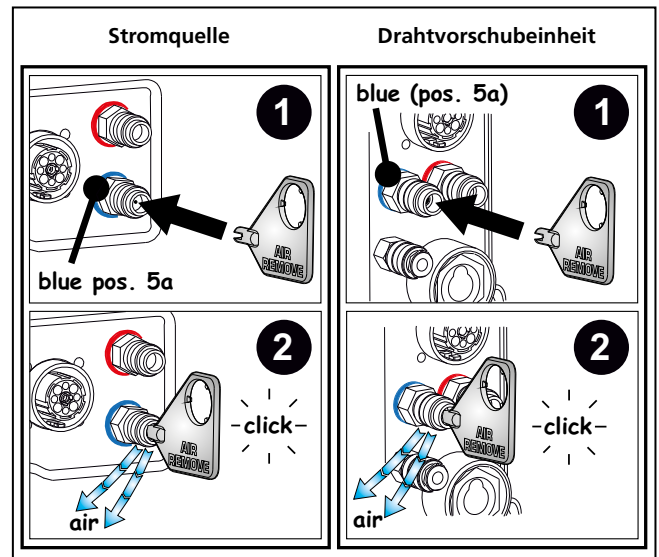

Schloss- und Drehfunktion MWF

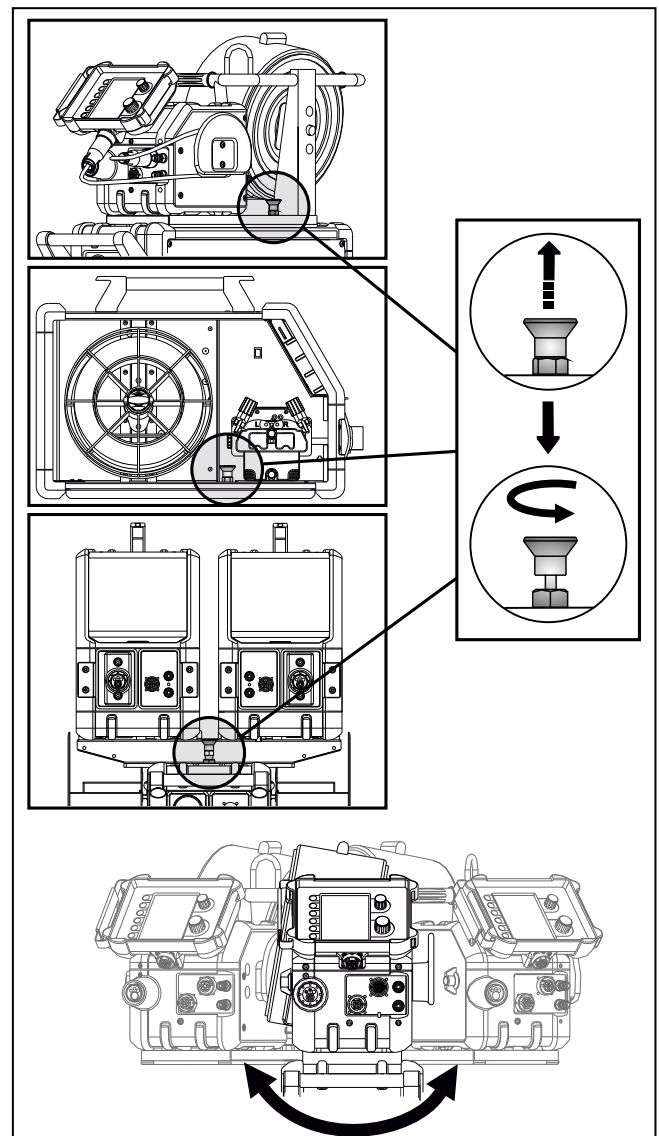

Anschluss und Inbetriebnahme

Montage der Teile in Drahtvorschubeinheit

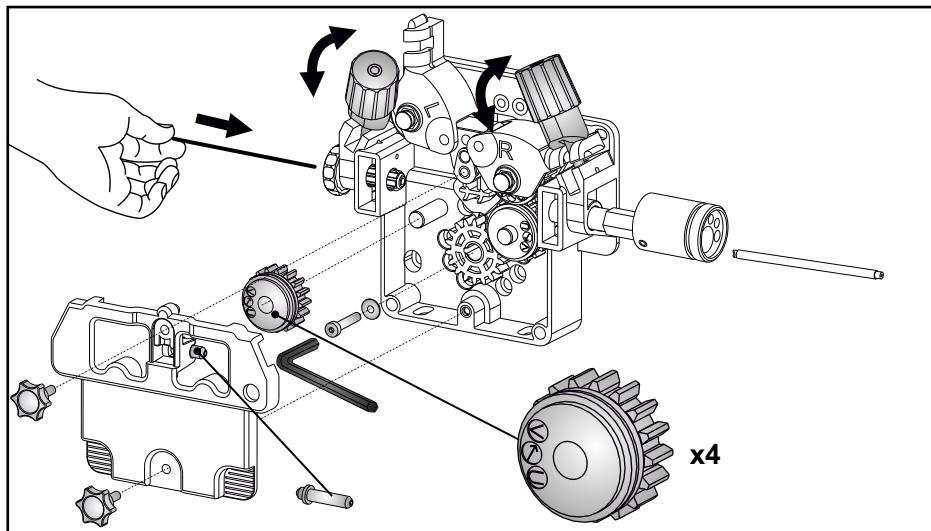

Mit Hilfe der Rändelschraube am Spannbolzen wird der Andruck der Förderrollen so eingestellt, daß eine gleichmässige Förderung des Drahtes gewährleistet ist, ohne den Draht zu deformieren.

Drahtförderung vorwärts/zurück

Wenn nicht geschweißt wird, lässt die Drahtförderung sich durch Betätigung einer der Tasten oder von der Roboterschnittstelle aus aktivieren, falls die MWF30-Einheit in einer Roboterlösung eingesetzt wird.

Drahtförderung

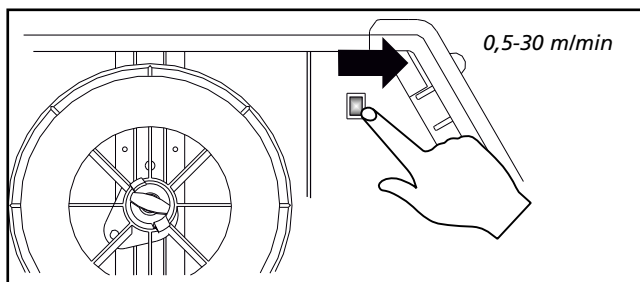

Drahtförderung MWF 30

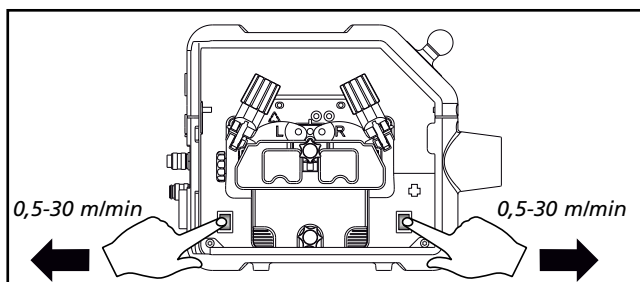

Drahtförderung Graphical

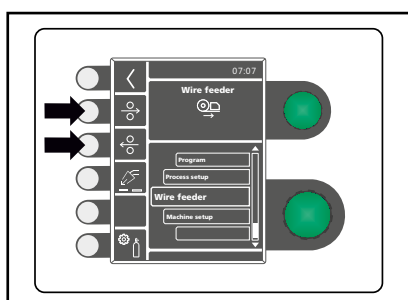

Software Einlesen

- Die SD-Karte einlegen.
- Die Maschine einschalten.
- Warten Sie, bis angezeigt wird, dass die Aktualisierung abgeschlossen ist.
- Die Maschine ausschalten und die SD-Karte entfernen.
- Die Maschine ist nun einsatzbereit.

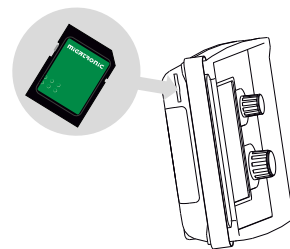

Neue Software wird in Stromquelle und alle anderen angeschlossenen Einheiten eingelesen.

Die Software kann auf <http://migatron.com> auf eine SD-Karte heruntergeladen werden. Die Dateisystem der SD-Karte muss auf FAT32 formatiert sein.

WICHTIG:
Die Software in der Mapenstruktur //MIGA_SW/SIGMA/ speichern.

Lizenz SW

Wenn mehr Programme oder Sonderfunktionen erkauf sind, werden die MigaLic. dat Datei sowie die anderen Softwarepackungen eingelesen. Bitte eine Sicherheitskopie der Software speichern.

Die MigalLic.txt Datei enthält Information über Maschinenlizenznummer und die gespeicherten Lizenzen auf der SD-Karte.

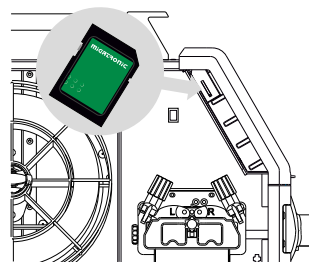

BASIC - Sonderfunktionen

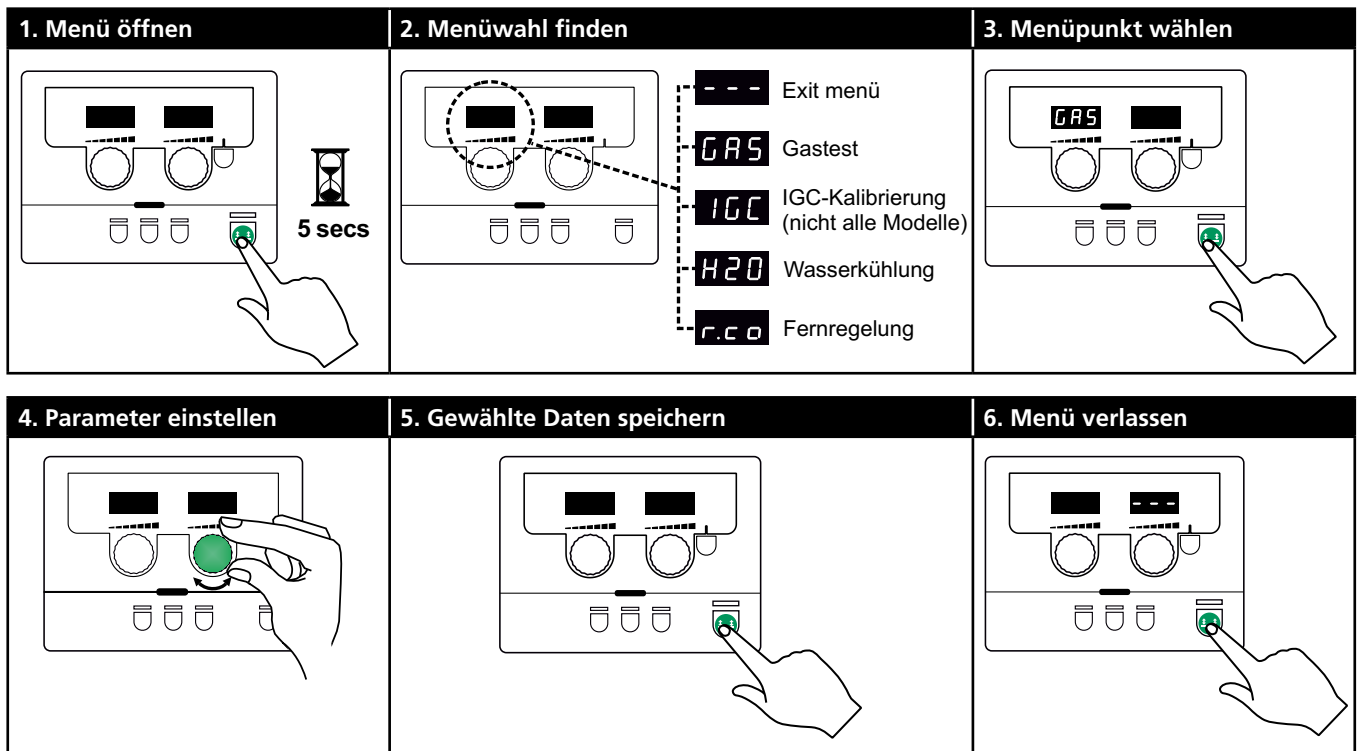

Parameter und Menüwahl

Langer Tastendruck auf die -Taste öffnet das Benutzermenü. Den linken Drehregler drehen bis das gewünschte Menü angezeigt wird. Mit dem rechten Drehregler lassen sich Einstellungen ändern, die im rechten Display angezeigt werden. Kurze Betätigung der -Taste aktiviert Funktionen wie z.B. Gastest.

Parameter- und Funktionswahlen im Benutzermenü:

--- **GAS** **IGC** **H2O** **r.c.o**

--- Zum Verlassen des Menüs die -Taste drücken

GAS GAsTest
Betätigung der -Taste öffnet bzw. sperrt den Gasmagnetventil. Wenn ein IGC-Kit installiert ist, lässt sich der Gasdurchfluss mittels des rechten Drehreglers einstellen.

IGC IGC-Kalibrierung
Nur sichtbar wenn IGC-Kit installiert ist.
Betätigung der -Taste startet die IGC-Kalibrierung.

H2O Wasserkühlung
Nur sichtbar wenn Kühleinheit installiert ist.

0: Wasserkühlung AUS
1: Wasserkühlung EIN

r.c.o Einstellung der Fernregelung
Folgende Einstellungen mittels des rechten Drehreglers ändern:

0: Ausgeschaltet
1: Dialog-Brenner (Artikel-Nr. 80100402)
2: Analoge Fernregelung (Artikel-Nr. 78815029)

BASIC - Sonderfunktionen

Konfiguration des Fernreglers

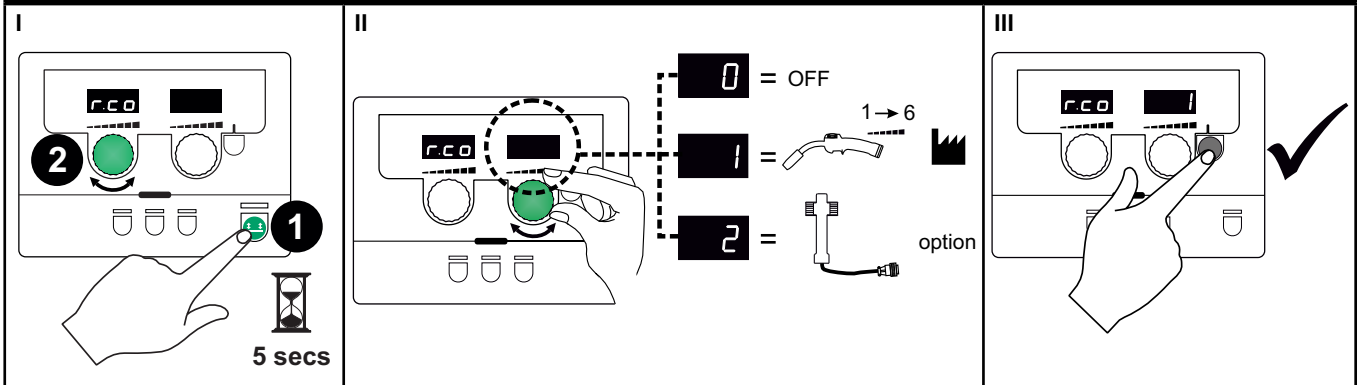

Schlossfunktion /

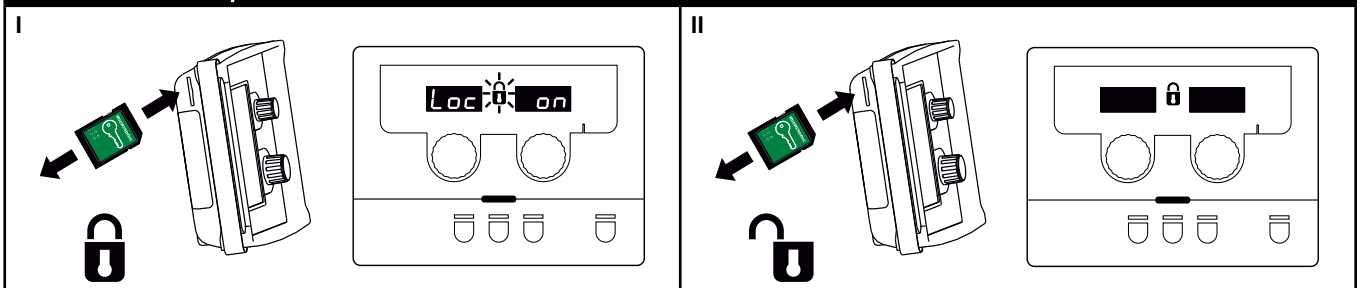

Kalibrierung des Gasdurchflusses (nicht alle Modelle)

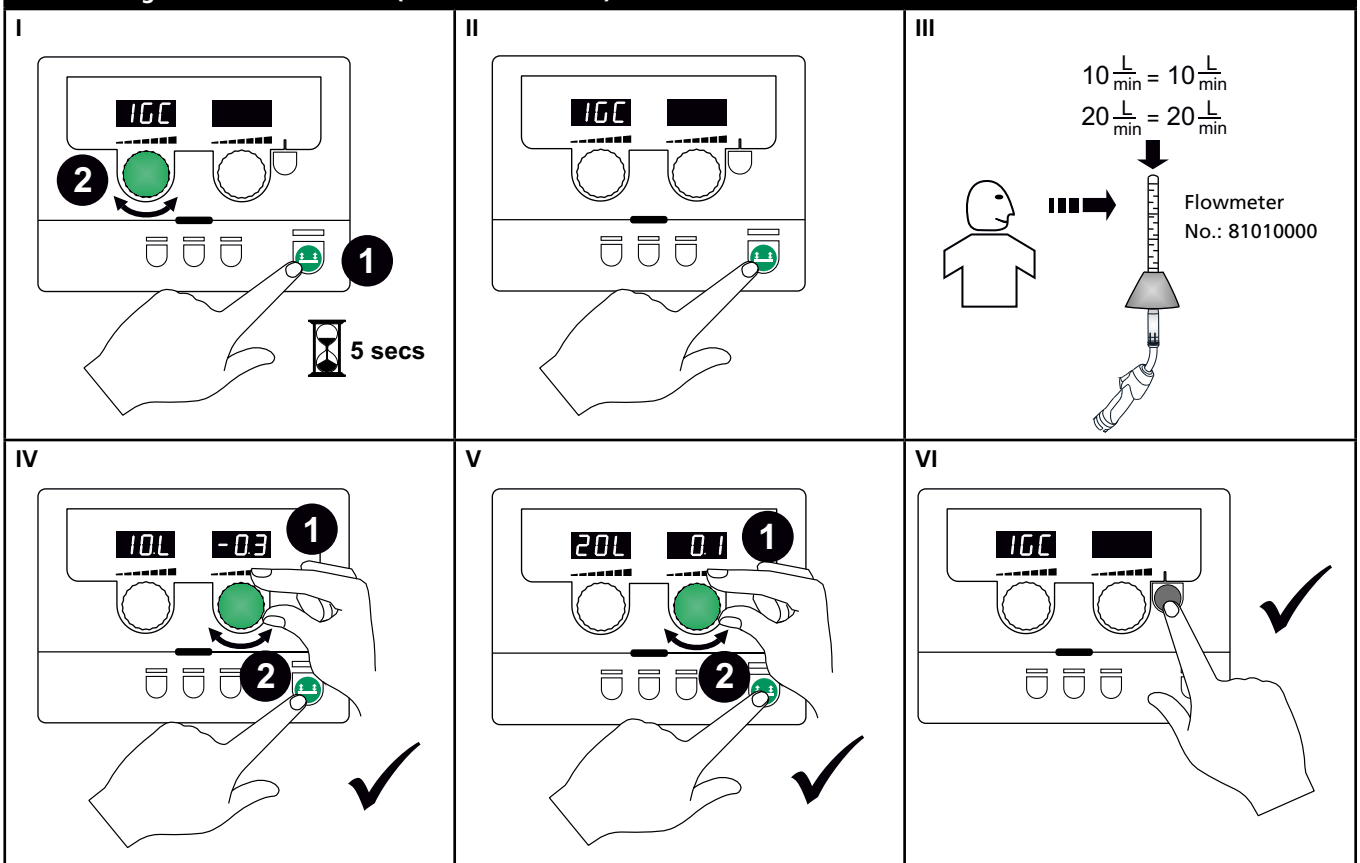

BASIC - Sonderfunktionen

Weisung der Softwareversion/Lizenznummer

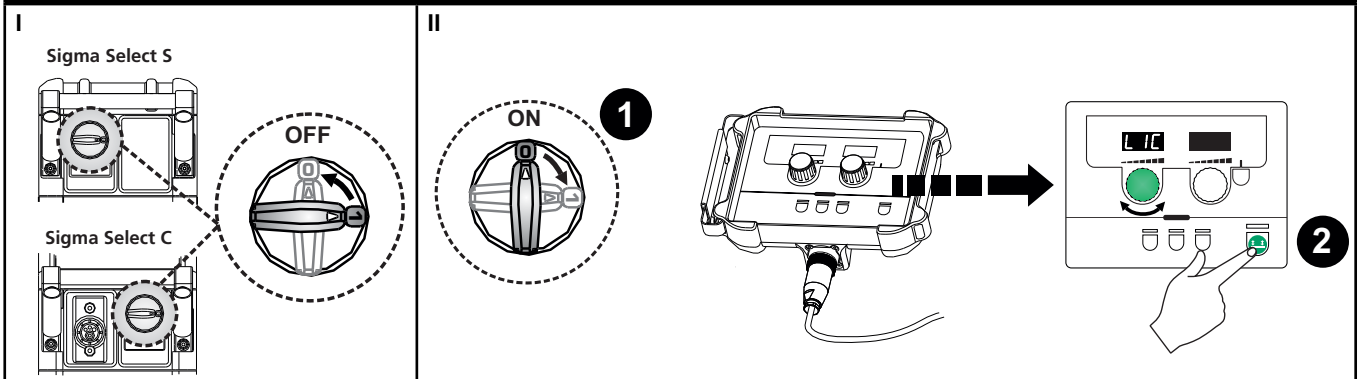

1. Lizenznummer

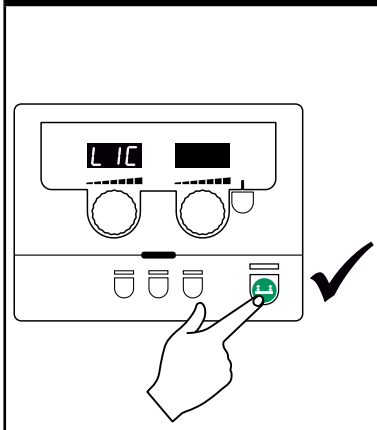

2. Anzeige der Lizenz-Nr. (12 Ziffer)

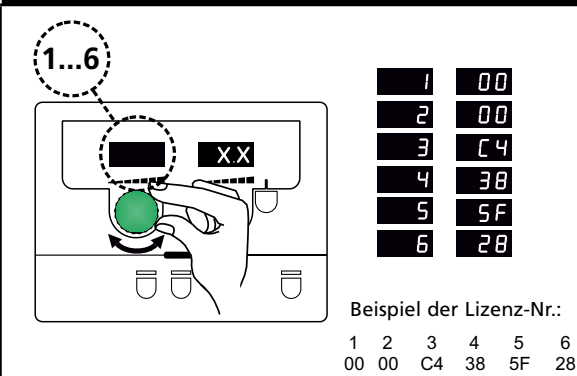

3. Zurück an SW-Versionen

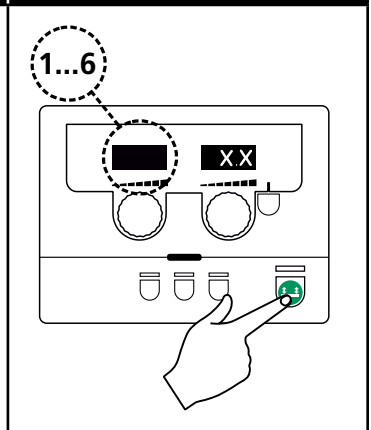

4. Wahl der SW

- Basic remote 1
- Welding package 2
- Main controller 3
- "-" 4
- "-" 5
- Wire feeder 6
- Wire feeder 7
- Arc controller 8
- "-" 9
- "-" 10
- "-" 11
- "-" 12
- "-" 13
- "-" 14
- "-" 15
- "-" 16
- Water controller 17
- Smart Torch 18

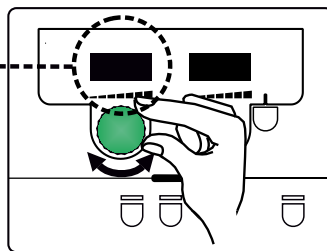

5. Menü verlassen

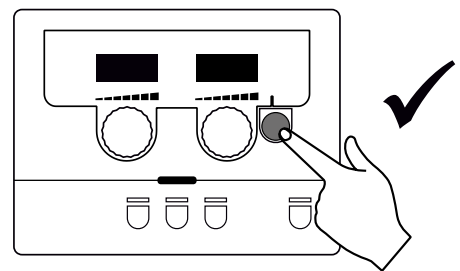



"-" not supported

BASIC - Fehlerhandhabung

Fehler-kodes	Ursache und Ausbesserung
E20-00 E20-02 E21-00 E21-06 E21-08	Es gibt keine Software in der E-Box Die Software auf die SD-Karte herunterladen, die SD-Karte in die Kontrolleinheit einsetzen und die Maschine einschalten. Die SD-Karte eventuell austauschen.
E20-01 E21-01	Die SD-Karte ist nicht formatiert Die SD-Karte in einem PC als FAT formatieren und die Software auf die SD-Karte herunterladen. Die SD-Karte eventuell austauschen.
E20-03 E21-02	Die SD-Karte hat mehrere Dateien mit demselben Namen Die SD-Karte formatieren und die Software wieder herunterladen.
E20-04	Die Kontrolleinheit hat versucht mehr Daten einzulesen als gespeichert werden können Die SD-Karte wieder einlesen oder austauschen. Migatronic-Kundendienst kontaktieren, wenn das Problem weiterhin besteht.
E20-05 E20-06	Die Software auf der SD-Karte ist für einen anderen Typ von E-Box zugelassen Eine SD-Karte anwenden, deren Software zu Ihrer E-Box passt.
E20-07	Der interne Kopierschutz erlaubt keinen Zugriff auf den Mikroprozessor Die SD-Karte wieder einlesen oder Migatronic-Kundendienst kontaktieren.
E20-08 E20-09 E21-05	Die Kontrolleinheit ist fehlerhaft Migmatronic-Kundendienst kontaktieren.
E20-10 E21-07	Die eingelesene Datei ist fehlerhaft Die SD-Karte wieder einlesen oder austauschen.
E21-03 E21-04	Das eingelesene Schweißprogramm-paket passt nicht zur Kontrolleinheit Eine SD-Karte anwenden, deren Software zu Ihrer Kontrolleinheit passt.
Err GAS	Gasfehler Gaszufuhr prüfen. Gasfehler abmelden durch kurzes Drücken einer beliebigen Taste.
E02-04	CAN-Kommunikationsfehler Zwischenschlauchpaket/Stecker prüfen.
E11-20	Stromsensorfehler 1. Stromsensor prüfen 2. Migatronic-Kundendienst kontaktieren

Fehlersymbole

 **Temperaturfehler**
Die Überhitzungsanzeige leuchtet auf, wenn der Schweißvorgang wegen Überhitzung der Maschine unterbrochen wurde. Lassen Sie die Maschine eingeschaltet, bis sie mittels des eingebauten Lüfters abgekühlt ist.

 **Stromfehler**
Der Indikator blinkt, wenn der Start- oder Schweißstrom zu hoch ist. Kontrollieren Sie bitte, dass Drahtgeschwindigkeit, Strom und Spannung korrekt eingestellt sind.



 **Anzeige von Fehlersymbolen**
Der Indikator blinkt, wenn andere Fehlerarten aufgetreten sind. Gleichzeitig wird das Fehlersymbol im Display angezeigt.

Ausgewählte Fehlercodes



 **E11 15** **Überspannungsfehler**
Der Indikator wird angezeigt, wenn die Netzspannung außerhalb der Toleranz liegt. Schließen Sie die Maschine bitte an: 400V AC +/- 15% 50-60 Hz.

 **Err H2O** **Kühlungsfehler**
Kühlungsfehler wird angezeigt auf Geräte, falls der Kühlkreislauf unterbrochen oder der Kühlmitteldurchfluss zu gering ist. Kontrollieren Sie bitte, dass die Kühleinheit korrekt angeschlossen ist und der Wasserbehälter ausreichend gefüllt ist. Überprüfen Sie den Schweißbrenner und die Wasserkühlanschlüsse.
Wenn die Kühlmittelviskosität wegen niedrigen Temperaturen reduziert ist, muss das Migatronic-Standardkühlmittel gegen das BTC-20 NF Kühlmittel 99290515 ausgetauscht werden, das sich durch seinen extrem niedrigen Leitwert und seine hohe Viskosität bis zu Temperaturen von -17 °C auszeichnet. Spülen Sie das System, bevor Sie eine neue Art von Kühlmittel hinzufügen.

Durch kurzes Drücken auf die -Taste wird der Kühlungsfehler abgemeldet.

 **Err GAS** **Gasfehler (IGC)**
Die Gasmenge ist zu gering oder zu groß. Kontrollieren Sie bitte, dass die Gaszufuhr höher als 2 bar und weniger als 6 bar ist, d.h. zwischen 5 l/min und 27 l/min. Gasfehler wird außer Tätigkeit gesetzt, wenn der manuelle Gasfluß zu 27 l/min eingestellt wird. Der Gasfehler wird durch kurzes Drücken auf die -Taste abgemeldet.

Drahtvorschubfehler

 **E01 00** oder  **E01 01**

Der Drahtvorschubmotor ist überlastet.
Der Drahtvorschubmotor oder das Magnetventil können defekt sein.

Andere Fehlertypen

Wenn andere Fehlersymbole im Display angezeigt werden, soll die Maschine aus- und eingeschaltet werden, damit das Symbol entfernt wird. Wenn das Fehlersymbol mehrmals erscheint, ist eine Reparatur der Stromquelle notwendig. Setzen Sie sich bitte mit Ihrem Händler in Verbindung, und teilen Sie ihm das Fehlersymbol mit.

Wenn separate Einheiten angeschlossen sind, können folgende Fehlercodes angezeigt werden:

 **E07 04** wird angezeigt, wenn die Kommunikation zwischen der Stromquelle und der (den) angeschlossenen Einheit(en) verloren ist.

 **E07 05** wird angezeigt, wenn die Motorsteuerung nicht korrekt funktioniert.

 **E07 06** wird angezeigt, wenn der Motor überlastet ist.

GRAPHICAL - Sonderfunktionen

Wizard-Aufstellung

I Language selection screen showing 'English /' selected.

II Date/Time and Hour setting screen. Time is 11:37, date is 2017-09-01, and hour is 11.

III Wire feeder setup 1 screen. A warning message states: '1 wire feeder(s) found, they must be configured individually.'

IV Torch setup screen. Options include 'Torch: CUT 2', 'Dialing', and 'Arcing mode'.

V Cooler setup screen. A warning message states: 'Water cooling has been detected, please verify that your torch might be damaged if its supports water cooling and water cooling is disabled.'

VI Setup completed screen. A message states: 'Setup completed. You can run the setup again from the machine setup menu.'

Sperrfunktion /

I Machine setup screen with a lock icon.

II Lock level screen (Level 1).

III Functions locked screen. A list of locked functions includes: 'Wire', 'Manual return', and 'Hot key'.

The bottom row shows the physical machine with a hand holding a green lock key, demonstrating the lock and unlock actions.

GRAPHICAL - Sonderfunktionen

Software/Lizenzen

I

II

III

Kabelkompensation (Kalibrierung des Widerstandes im Schweißbrenner)

I

II

III

IV

! Die Oberfläche des Werkstücks muss rein sein zur Sicherstellung des guten Kontakts mit dem Brenner.

V

VI

= Kabelkompensation aktiviert

Einstellung des Schweißbrenners

I

II

GRAPHICAL - Sonderfunktionen

Kalibrierung des Gasdurchflusses (nicht alle Modelle)

I

II

III

IV

V

GRAPHICAL - Fehlerhandhabung

Die SIGMA Select hat ein fortschrittliches Selbstschutz-System. Die Maschine automatisch stoppt die Gaszufuhr, unterbricht den Schweißstrom und stoppt die Drahtzuführung, wenn ein Fehler auftritt.

Ausgewählte Fehler:

Kühlungsfehler

Kühlungsfehler wird angezeigt auf Geräte, falls der Kühlkreislauf unterbrochen oder der Kühlmitteldurchfluss zu gering ist. Kontrollieren Sie bitte, dass die Kühleinheit korrekt angeschlossen ist und der Wasserbehälter ausreichend gefüllt ist. Überprüfen Sie den Schweißbrenner und die Wasserkühlanschlüsse.



Wenn die Kühlmittelviskosität wegen niedrigen Temperaturen reduziert ist, muss das Migatronic-Standardkühlmittel gegen das BTC-20 NF Kühlmittel 99290515 ausgetauscht werden, das sich durch seinen extrem niedrigen Leitwert und seine hohe Viskosität bis zu Temperaturen von -17 °C auszeichnet. Spülen Sie das System, bevor Sie eine neue Art von Kühlmittel hinzufügen.

Durch kurzes Drücken auf die ✓-Taste wird der Kühlungsfehler abgemeldet.

Gas Fehler (IGC)

Die Gasmenge ist zu gering oder zu groß. Kontrollieren Sie bitte, dass die Gaszufuhr höher als 2 bar und weniger als 6 bar ist, d.h. zwischen 5 l/min und 27 l/min. Gasfehler wird außer Tätigkeit gesetzt, wenn der manuelle Gasfluß zu 27 l/min eingestellt wird. Der Gasfehler wird durch kurzes Drücken auf die ✓-Taste abgemeldet.

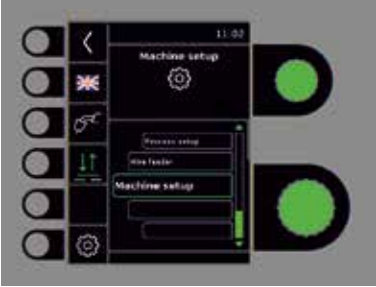
Achtung: Es ist wichtig, dass die angegebene Gaszufuhr während des Schweißens aufrechterhalten werden kann.

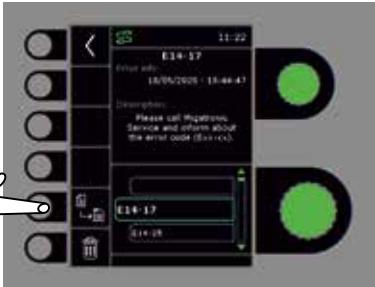
Fehlerliste	
I	II
	
III	IV
	<p>Fehlerliste Alle Fehler sind in der Maschine im Menü Service gespeichert. Die Fehlerliste kann durch Einsetzen einer SD-Karte und Drücken der folgenden Taste kopiert werden: Die Fehlerliste ist dann auf der SD-Karte gespeichert. Die Fehlerliste kann durch Drücken der Taste mit dem Mülleimer gelöscht werden.</p> <div style="text-align: center;">  </div>

Technische Daten 1

STROMQUELLE SIGMA Select	300		300 IAC		400		400 IAC		550	
Netzspannung $\pm 15\%$ (50-60Hz), V	3x400		3x400		3x400		3x400		3x400	
Mindestgröße des Generators, kVA	16		19		27		29		40	
¹⁾ Minimum Kurzschlussleistung, MVA	3,7		4,3		6,0		6,0		9,5	
Sicherung, A	16		16		20		20		35	
Effektiver Netzstrom, A	11,0		16,0		17,5		16,5		27,2	
Max. Netzstrom, A	15,4		18,3		26,0		28,2		39,2	
Leistung 100%, kVA	9,0		11,1		12,1		11,4		18,9	
Leistung max., kVA	10,7		12,7		18,0		19,5		27,1	
Leistung Leerlauf, W	11		13		12		13		12	
Wirkungsgrad, %	87		85		89		85		90	
Leistungsfaktor	0,90		0,90		0,90		0,90		0,90	
	MIG	MMA	MIG	MMA	MIG	MMA	MIG	MMA	MIG	MMA
Strombereich, A	15-300	15-250	15-300	15-300	15-400	15-400	15-400	15-400	15-550	15-550
Zulässige ED 100% 20°C, A	290/28,5	250/30,0	300/29,0	300/32,0	345/31,5	345/33,8	310/29,5	310/32,5	475/37,8	475/39,0
Zulässige ED max. 20°C, A/%V					400/65/34,0	400/65/36,0	400/60/34,0	400/60/36,0	550/60/41,5	550/60/42,0
Zulässige ED 100% 40°C, A/V	220/25,0	220/28,8	270/27,5	270/30,8	300/29,0	300/32,0	280/28,0	280/31,2	430/35,5	430/37,2
Zulässige ED 60% 40°C, A/V	240/26,0	230/29,2			370/32,5	370/34,8	350/31,5	350/34,0	510/39,5	510/40,4
Zulässige ED max. 40°C, A/%V	300/25/29,0	250/40/30,0	300/80/29,0	300/80/32,0	400/50/34,0	400/45/36,0	400/40/34,0	400/40/36,0	550/50/41,5	550/50/42,0
Leerlaufspannung, V	50-60		65-70		65-70		65-70		75-80	
²⁾ Anwendungsklasse, C // S	S/CE // S/CE		S/CE // S/CE		S/CE // S/CE		S/CE // S/CE		S/CE // S/CE	
³⁾ Schutzklasse	IP23S		IP23		IP23		IP23		IP23	
Norm, C	IEC60974-1, IEC60974-5, IEC60974-10 Cl. A									
Norm, S	IEC60974-1, IEC60974-10 Cl. A									
Maße C (HxBxL), mm	700x260x735		700x260x735		700x260x735		700x260x735		700x260x735	
Maße S (HxBxL), mm	454x260x735		454x260x735		454x260x735		454x260x735		454x260x735	
Gewicht C / S, kg	36,9 / 26		53 / 36		52 / 35		53 / 36		53 / 36	

STROMQUELLE SIGMA Select	300 Boost				300 IAC Boost			
Netzspannung $\pm 10\%$ (50-60Hz), V	3x208-380				3x380-440			
Mindestgröße des Generators, kVA	16				25			
¹⁾ Minimum Kurzschlussleistung, MVA	1,7				3,75			
Sicherung, A	20				16			
Effektiver Netzstrom, A	19,5				10,6			
Max. Netzstrom, A	31,6				16,2			
Leistung 100%, kVA	7,1				7,0			
Leistung max., kVA	11,0				10,6			
Leistung Leerlauf, W	45				16			
Wirkungsgrad, %	82				87			
Leistungsfaktor	0,95				0,95			
	MIG	MMA	MIG	MMA	MIG	MMA	MIG	MMA
Strombereich, A	15-300	15-250	15-300	15-250	15-300	15-300	15-300	15-300
Zulässige ED 100% 20°C, A	250/26,5		250/26,5		300/29,0		300/32,0	
Zulässige ED max. 20°C, A/%V	300/40/29,0		300/40/29,0					
Zulässige ED 100% 40°C, A/V	200/24,0	200/28,0	200/24,0	200/28,0	250/26,5	220/28,8	250/26,5	220/28,8
Zulässige ED 60% 40°C, A/V	210/24,5	210/28,4	210/24,5	210/28,4	270/27,5	250/30,0	270/27,5	250/30,0
Zulässige ED max. 40°C, A/%V	300/25/29,0	250/35/30,0	300/25/29,0	250/35/30,0	300/35/29,0	300/30/32,0	300/35/29,0	300/30/32,0
Leerlaufspannung, V	50-60				70-75			
²⁾ Anwendungsklasse, C // S	S/CE // S/CE				S/CE // S/CE			
³⁾ Schutzklasse	IP23S				IP23			
Norm, C	IEC60974-1, IEC60974-5, IEC60974-10 Cl. A				IEC60974-1, IEC60974-5, IEC60974-10 Cl. A			
Norm, S	IEC60974-1, IEC60974-10 Cl. A				IEC60974-1, IEC60974-10 Cl. A			
Maße C (HxBxL), mm	700x260x735				900x260x735			
Maße S (HxBxL), mm	454x260x735				654x260x735			
Gewicht C / S, kg	45 / 34				66 / 49			

- Dieses Gerät entspricht den EN / IEC1000-3-12:2014 (/ 2011), sofern die Kurzschlussleistung S_{sc} der Netzversorgung am Netzstecker größer als oder gleich die angegebenen Daten im obenerwähnten Schema ist. Es ist die Verantwortung des Elektroinstallateurs oder der Anwender des Gerätes zu gewährleisten, eventuell durch Rücksprache mit dem Netzbetreiber, dass das Gerät nur an eine Stromversorgung mit Kurzschlussleistung S_{sc} größer als oder gleich wie die angegebenen Daten im obenerwähnten Schema angeschlossen ist.
- S** Erfüllt die Anforderungen an Geräte zur Anwendung unter erhöhter elektrischer Gefährdung
- Die Maschine ist für den Innen- und Außenbereich gemäß der Schutzklasse IP23 / IP23S ausgelegt.
IP23S: Die Maschine kann gelagert werden, darf jedoch nicht während eines Niederschlags im Freien verwendet werden. Es sei denn, sie wird dagegen geschützt.

Technische Daten 2

STROMQUELLE SIGMA Select	400 Boost				400 IAC Boost			
Netzspannung $\pm 10\%$ (50-60Hz), V	3x208-380		3x380-440		3x208-380		3x380-440	
Mindestgröße des Generators, kVA	25		25		25		25	
¹⁾ Minimum Kurzschlussleistung, MVA					4,0		4,0	
Sicherung, A	25-50		25-50		25-50		25-50	
Effektiver Netzstrom, A	22,0		11,7		24,8		11,8	
Max. Netzstrom, A	45,0		23,5		48,0		24,5	
Leistung 100%, kVA	8,3		8,1		8,5		8,5	
Leistung max., kVA	16,7		16,3		17,4		17,4	
Leistung Leerlauf, W	60		56		60		71	
Wirkungsgrad, %	84		88		82		85	
Leistungsfaktor	0,96		0,95		0,96		0,96	
	MIG	MMA	MIG	MMA	MIG	MMA	MIG	MMA
Strombereich, A	15-400	15-400	15-400	15-400	15-400	15-400	15-400	15-400
Zulässige ED 100% 20°C, A	300/29,0	300/32,0	300/29,0	300/32,0	300/29,0	300/32,0	300/29,0	300/32,0
Zulässige ED max. 20°C, A/%N	400/30/34,0	400/30/32,0	400/30/34,0	400/30/32,0	400/30/34,0	400/30/32,0	400/30/34,0	400/30/32,0
Zulässige ED 100% 40°C, A/N	250/26,5	220/28,8	250/26,5	220/28,8	250/26,5	220/28,8	250/26,5	220/28,8
Zulässige ED 60% 40°C, A/N	280/28,0	260/30,4	280/28,0	260/30,4	280/28,0	260/30,4	280/28,0	260/30,4
Zulässige ED max. 40°C, A/%N	400/25/34,0	400/20/36,0	400/25/34,0	400/20/36,0	400/25/34,0	400/20/36,0	400/25/34,0	400/20/36,0
Leerlaufspannung, V	70-75				70-75			
²⁾ Anwendungsklasse, C // S	S/CE // S/CE				S/CE // S/CE			
³⁾ Schutzklasse	IP23				IP23			
Norm, C	IEC60974-1, IEC60974-5, IEC60974-10 Cl. A				IEC60974-1, IEC60974-5, IEC60974-10 Cl. A			
Norm, S	IEC60974-1, IEC60974-10 Cl. A				IEC60974-1, IEC60974-10 Cl. A			
Maße C (HxBxL), mm	900x260x735				900x260x735			
Maße S (HxBxL), mm	654x260x735				654x260x735			
Gewicht C / S, kg	66 / 49				67 / 50			

DRAHTVORSCHUBEINHEIT MWF			
Drahtfördergeschwindigkeit, m/min	0,5-30,0		
Brenneranschluss	EURO		
Drahtspulendurchmesser, mm	300		
Drahtspule, kg	5-18		
Zulässige ED 100% 40°C, A/%	430		
Zulässige ED 60% 40°C, A/%	500		
Zulässige ED max. 40°C, A/%	550/50		
³⁾ Schutzklasse	IP23		
Drahtdurchmesser, mm	0,6-1,6		
Gasdruck, MPa (bar)	0,6 (6,0)		
	MWF 30	MWF 32	MWF 33
Maße (HxBxL), mm	413x310x750	457x260x672,5	457x260x672,5
Gewicht, kg	11,6	14,0	14,0
Norm	IEC60974-5, IEC60974-10 CL. A		

KÜHLEINHEIT MCU 1300	
Kühlleistung (1 l/min), W	1300
Kühlleistung (1,5 l/min), W	1600
Tankkapazität, liter	5
Durchflussmenge, bar - °C - l/min	3,0-60-1,5
Druck max., bar	5
Norm	IEC60974-2, IEC60974-10 CL.A
Maße (HxBxL), mm	207x260x680
Gewicht	20

EU-KONFORMITÄTSERKLÄRUNG

CE

MIGATRONIC A/S
Aggersundvej 33
9690 Fjerritslev
Dänemark

erklärt, dass das unten erwähnte Gerät
Typ: SIGMA Select
den Bestimmungen der EU-Richtlinien
2014/35/EU
2014/30/EU
2011/65/EU entspricht

Europäische Normen: EN IEC60974-1:2018/A1:2019
EN IEC60974-2:2019
EN IEC60974-5:2019
EN / IEC60974-10:2014/A1:2015

Verordnung: 2019/1784/EU

Ausgestellt in Fjerritslev am 10.02.2021

Kristian M. Madsen
Kristian M. Madsen
CEO

- Dieses Gerät entspricht den EN / IEC61000-3-12:2014 (/ 2011), sofern die Kurzschlussleistung S_{sc} der Netzversorgung am Netzstecker größer als oder gleich die angegebenen Daten im obenerwähnten Schema ist. Es ist die Verantwortung des Elektroinstallateurs oder der Anwender des Gerätes zu gewährleisten, eventuell durch Rücksprache mit dem Netzbetreiber, dass das Gerät nur an eine Stromversorgung mit Kurzschlussleistung S_{sc} größer als oder gleich wie die angegebenen Daten im obenerwähnten Schema angeschlossen ist.
- S** Erfüllt die Anforderungen an Geräte zur Anwendung unter erhöhter elektrischer Gefährdung
- Die Maschine ist für den Innen- und Außenbereich gemäß der Schutzklasse IP23 / IP23S ausgelegt.
IP23S: Die Maschine kann gelagert werden, darf jedoch nicht während eines Niederschlags im Freien verwendet werden. Es sei denn, sie wird dagegen geschützt.

Branchement et fonctionnement

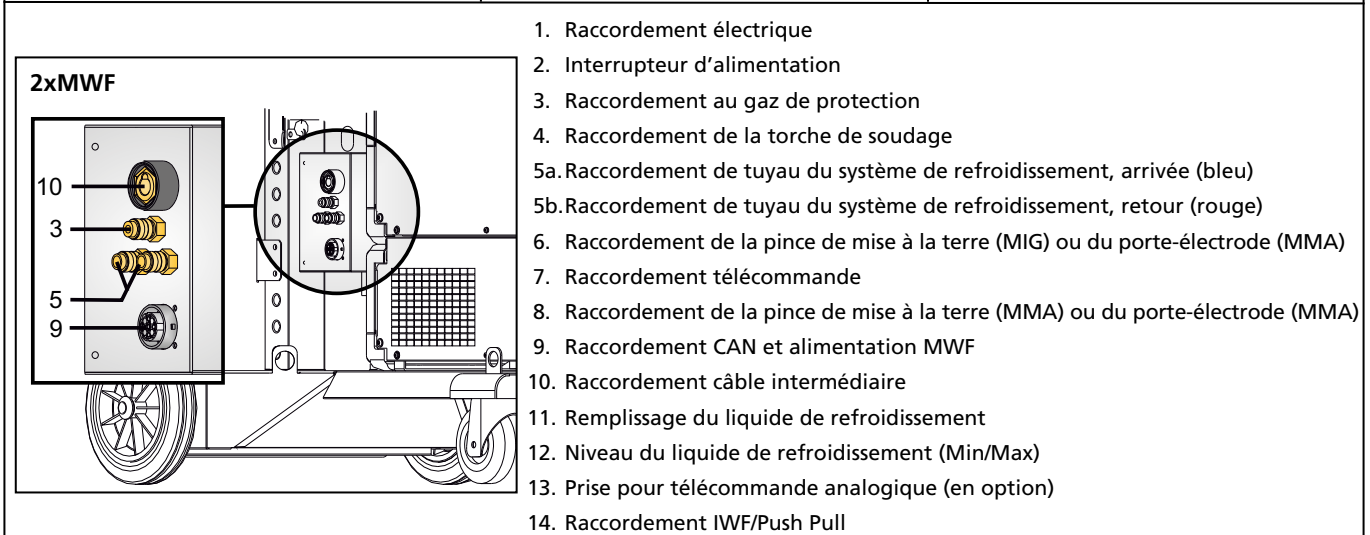
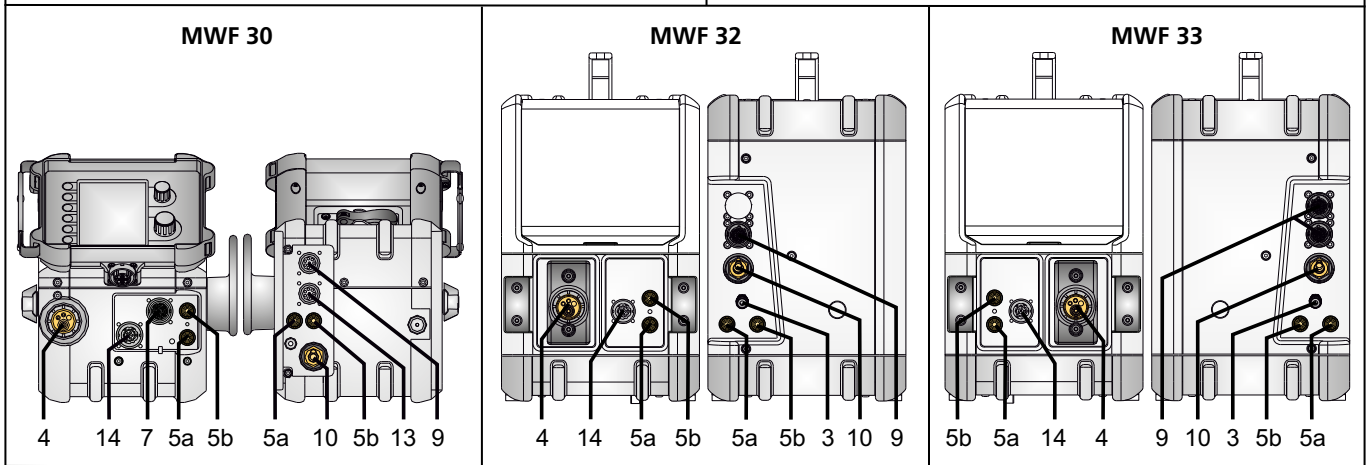
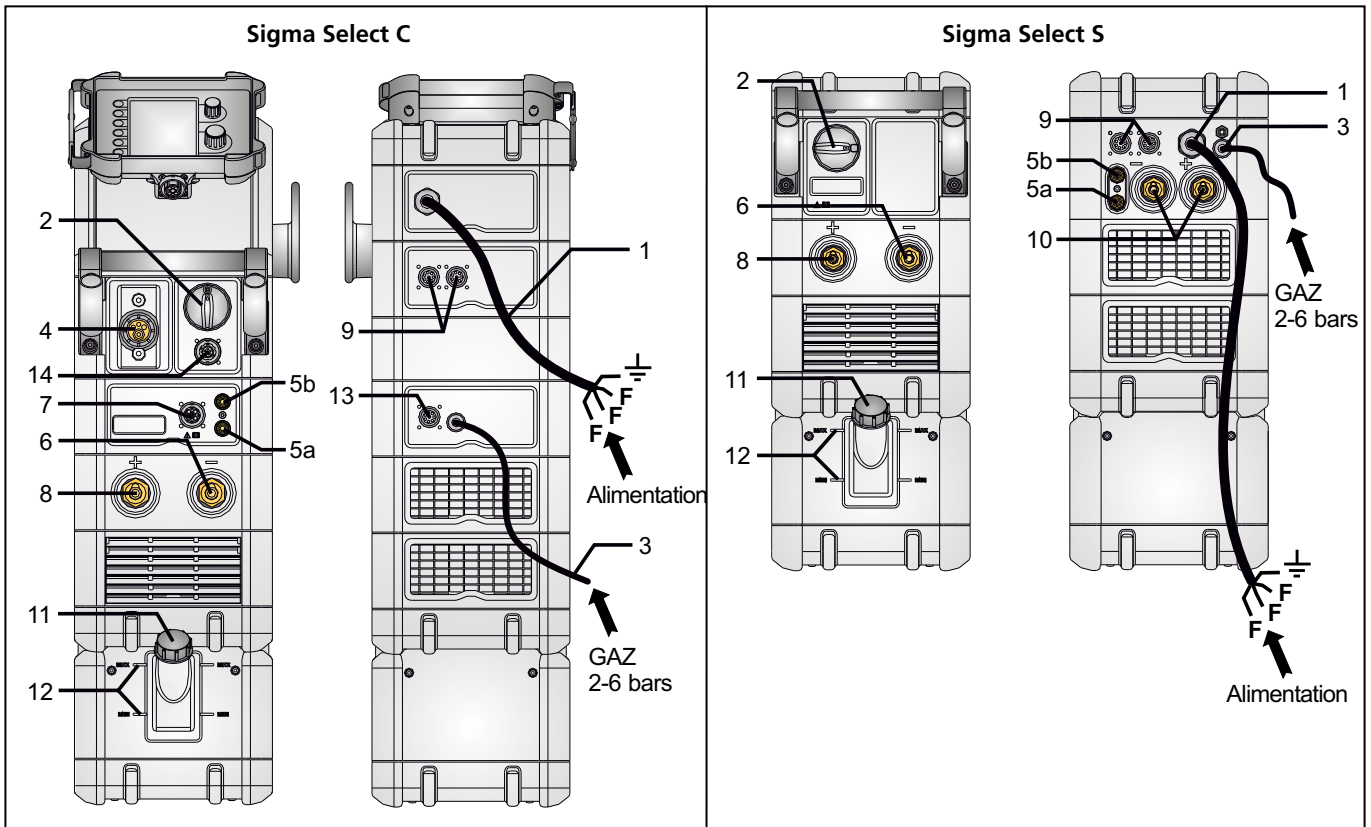

Branchement et fonctionnement



Attention

Lisez attentivement la fiche de mise en garde/le mode d'emploi avant la première utilisation et conservez ces informations en vue de leur utilisation ultérieure.

Installation autorisée

Raccordement électrique

Branchez la machine à une prise secteur adaptée. Veuillez lire la plaque signalétique (U_i) à l'arrière de la machine.

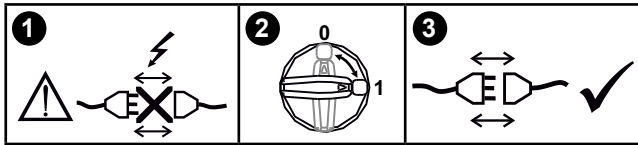
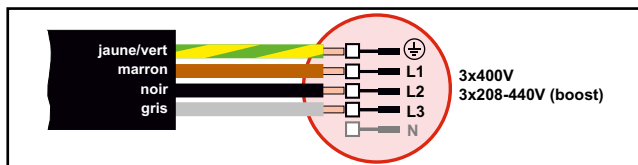

Kit de stabilisation de la tension

La source d'alimentation est configurable avec un Kit de stabilisation de la tension ; celui-ci prévient les variations de tension plus importantes. Par exemple : en cas d'utilisation du générateur et lorsque la machine est branchée à une alimentation séparée.

Raccordement au gaz de protection

Raccorder le tuyau de gaz qui se trouve sur le panneau arrière de la machine (3) et le relier à une alimentation en gaz avec régulateur de pression (2-6 bars). (Remarque : pour une utilisation optimale, certains types de régulateurs de pression nécessitent une pression de sortie supérieure à 2 bars). Une/deux bouteilles de gaz peuvent être installées à l'arrière du chariot.

Consommation de gaz

Selon la tâche de soudage, le type de gaz et la conception de la soudure, la consommation de gaz varie entre 6 et 7 l/min à faible ampérage (<25A) et jusqu'à 27 l/min au maximum.

Consommation de matériaux

La consommation de matériaux peut être estimée en calculant le temps de soudage en minutes multiplié par la vitesse d'alimentation du fil (m/min) multiplié par le poids par mètre des consommables de soudure utilisés.

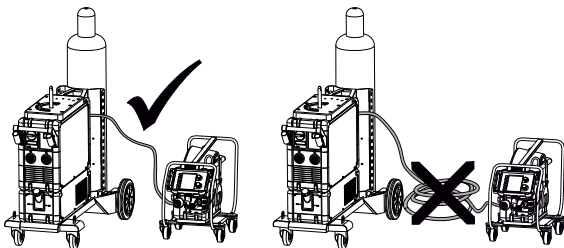

Attention

L'activation de la gâchette de la torche génère une tension au niveau du fil de soudage/de l'électrode.

Raccordement de la torche de soudage

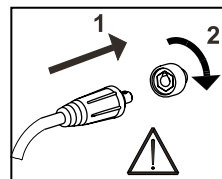
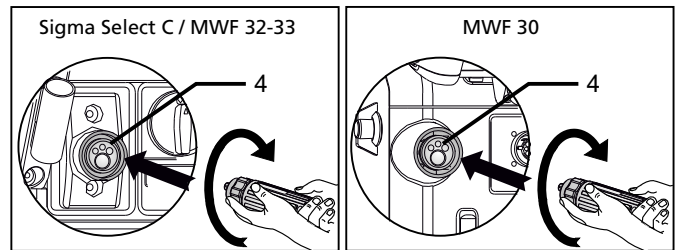

Important !

Afin d'éviter la destruction des prises et câbles, assurez-vous que le contact électrique est bien établi lors du branchement des câbles de mise à la terre et des torches de soudage à la machine.

Branchement du porte-électrode pour le soudage MMA

Le porte-électrode et le câble de mise à la terre sont branchés sur la borne plus (10) et la borne moins (8). Respectez les instructions relatives à la polarité indiquées par le fournisseur des électrodes.

Dimensions de câble recommandées

Courant de soudage	Courant Continu	Pulsé
200 A	35 mm ²	35 mm ²
300 A	50 mm ²	70 mm ²
400 A	95 mm ² / 2x50 mm ²	95 mm ² / 2x50 mm ²
550 A	2x70 mm ²	2x70 mm ²

Procédé de soudage	Distance par rapport à la pièce (a+b)	Longueur totale du câble dans le circuit de soudage (a+b+c)
MIG - IAC et pulsé	10 m	20 m
MIG - non pulsé	30 m	60 m

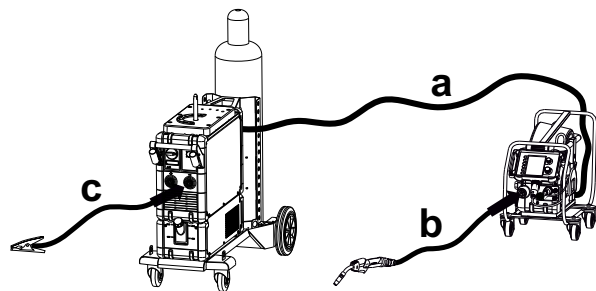

Réglage du frein du dévidoir

Le frein du dévidoir ralentit la bobine en fonction de l'avancement du fil de soudage.

Le degré de freinage dépend du poids de la bobine et de la vitesse de dévidage. La valeur par défaut est de 15 kg.

Réglage :

- Démonter le bouton de réglage en plaçant un petit tournevis derrière le bouton, puis sortir ce dernier.
- Régler le frein en serrant ou desserrant l'écrou autobloquant au niveau de l'axe du moyeu.
- Réinstaller le bouton.

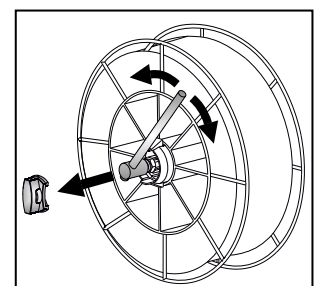

Branchement et fonctionnement

Instructions de levage

Veillez à respecter les points de levage indiqués (voir figure) lors du levage de la machine ou du dévidoir MWF. Il est important de retirer les bouteilles de gaz avant de procéder au levage de la machine, le cas échéant.

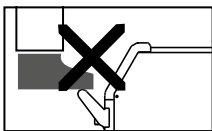
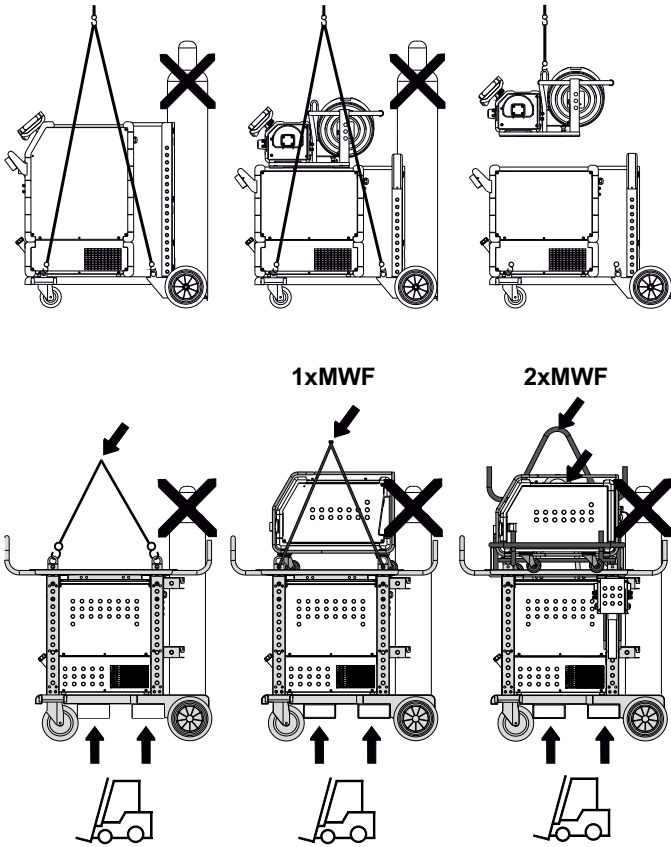

Ne pas soulever la machine par la poignée.
Ne pas marcher sur la poignée.

Installation de la télécommande

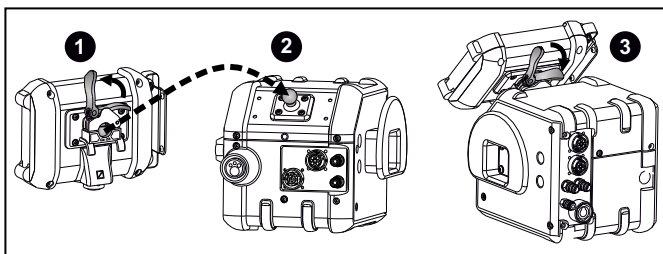

Enroulement du câble du MWF 30

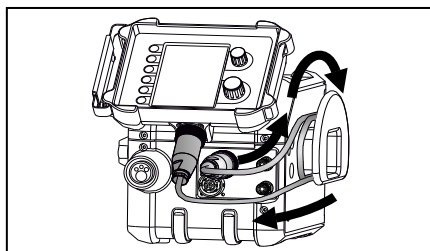

Ventilation MCU

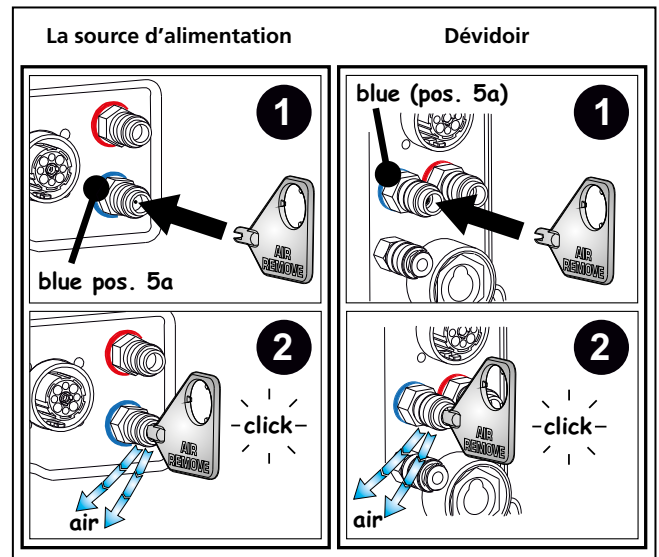

Fonction de pivotement du MWF

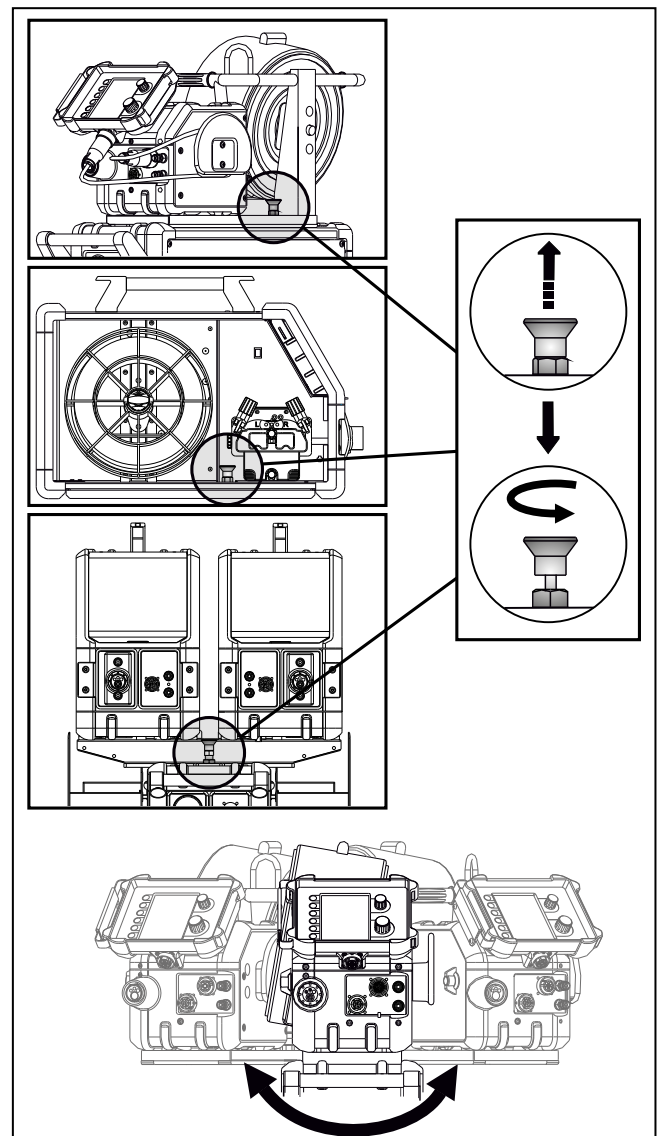

Branchement et fonctionnement

Assemblage des pièces dans le dévidoir

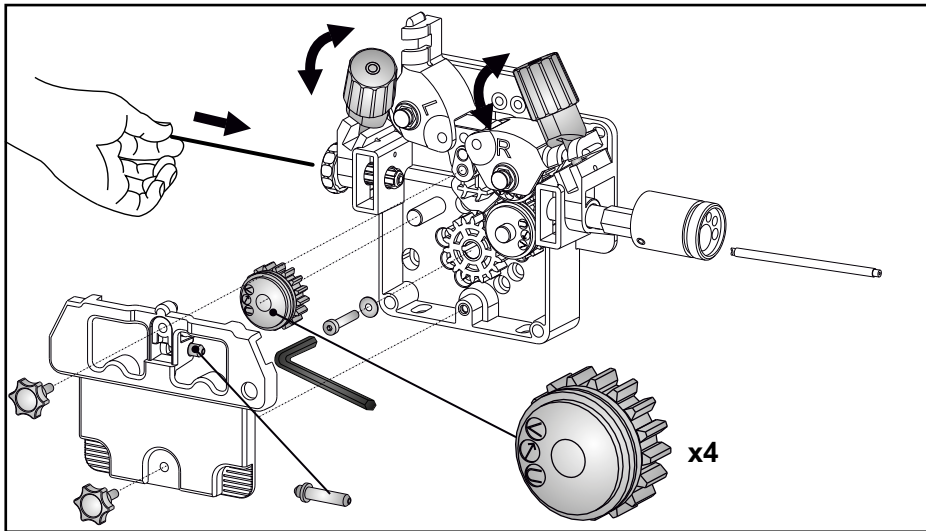

Le réglage de la pression sur le galet doit permettre l'arrêt du fil au niveau du tube de contact

Avance pas à pas du fil

Lorsque la machine est en veille, l'avance pas à pas du fil peut être activée par une pression sur l'une des touches ou à partir de l'interface robot, si le dévidoir MWF30 est intégré à un système robotisé.

Avance pas à pas du fil

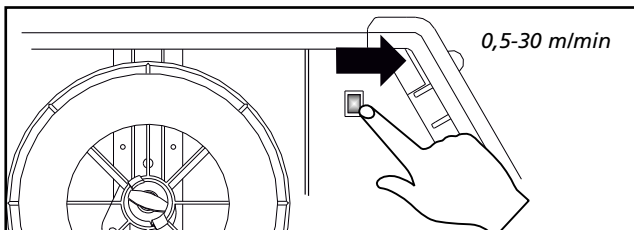

Avance pas à pas du fil MWF 30

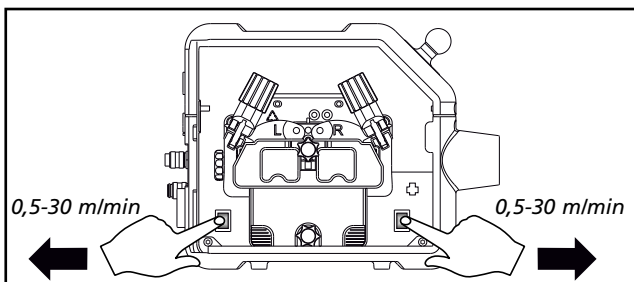

Avance pas à pas du fil Graphical

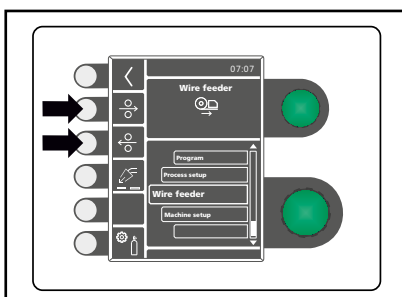

Mise à jour du logiciel

- Insérer la carte SD
- Démarrer la machine
- Patienter jusqu'à ce que la machine indique la fin de la mise à jour.
- Éteindre la machine et retirer la carte SD.
- La machine est désormais prête à l'emploi.

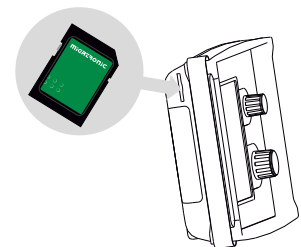

Le nouveau logiciel est alors chargé dans le module d'alimentation ainsi que dans tous les dispositifs raccordés à la machine.

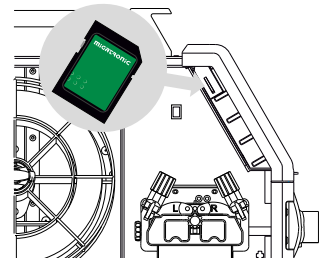

Vous pouvez télécharger le logiciel à l'adresse suivante

<http://migatron.com> sur une carte SD. Le système de fichiers de la carte SD doit être formaté en FAT32.

IMPORTANT :

Enregistrez le Software dans le //MIGA_SW/SIGMA/ file structure.

Licences logiciel

En cas d'achat de licences supplémentaires pour des programmes ou des fonctions spécifiques, les fichiers MigaLic.dat doivent être chargés de la même manière que les progiciels. Il est important de créer un fichier de sauvegarde.

Le fichier MigaLic.txt contient les informations sur le numéro de licence de la machine et sur les licences de la carte SD.

BASIC - Fonctions spéciales

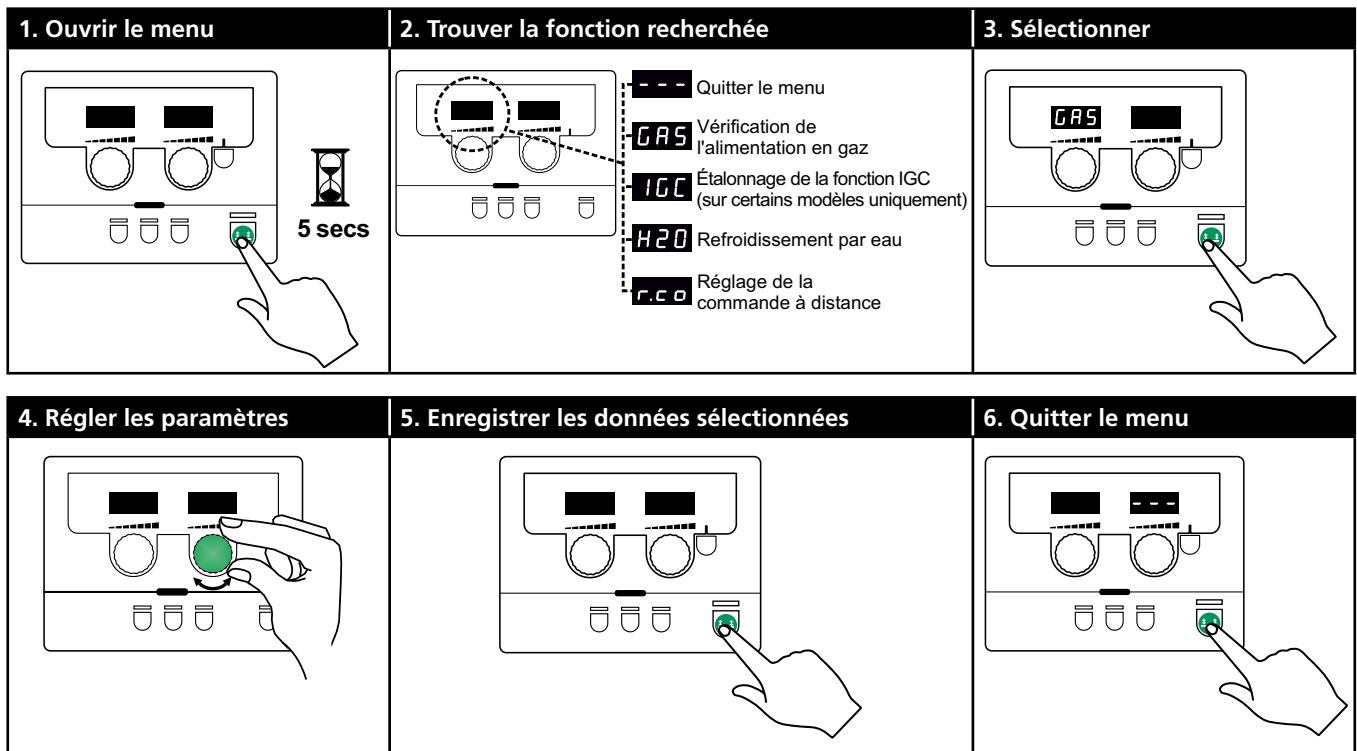

Paramètres et fonctions du menu

Appuyez longuement sur la touche pour ouvrir le menu utilisateur. Tournez le bouton de réglage gauche jusqu'à l'affichage du menu souhaité. Utilisez le bouton de réglage droit pour modifier les paramètres affichés dans l'écran droit. Appuyez brièvement sur la touche pour activer une fonction, notamment pour vérifier l'alimentation en gaz.

Fonctions et paramètres du menu utilisateur :

--- **GAS** **IGC** **H2O** **r.c.o**

--- Appuyez sur la touche pour quitter le menu.

GAS Vérification de l'alimentation en gaz
Appuyez sur la touche pour ouvrir et fermer l'arrivée de gaz. Si un kit IGC est installé, vous pouvez régler le débit gazeux à l'aide du bouton droit.

IGC Étalonnage de la fonction IGC
Visible uniquement lorsqu'un kit IGC est installé.
Appuyez sur la touche pour procéder à l'étalonnage de la fonction IGC.

H2O Refroidissement par eau
Visible uniquement lorsqu'un module de refroidissement est installé.

0: Refroidissement par eau OFF

1: Refroidissement par eau ON

r.c.o Réglage de la commande à distance
Utilisez le bouton droit pour modifier les paramètres suivants

0: désactivé

1: torche Dialog (référence 80100402)

2: télécommande analogique (référence 78815029)

BASIC - Fonctions spéciales

Configuration de la commande externe

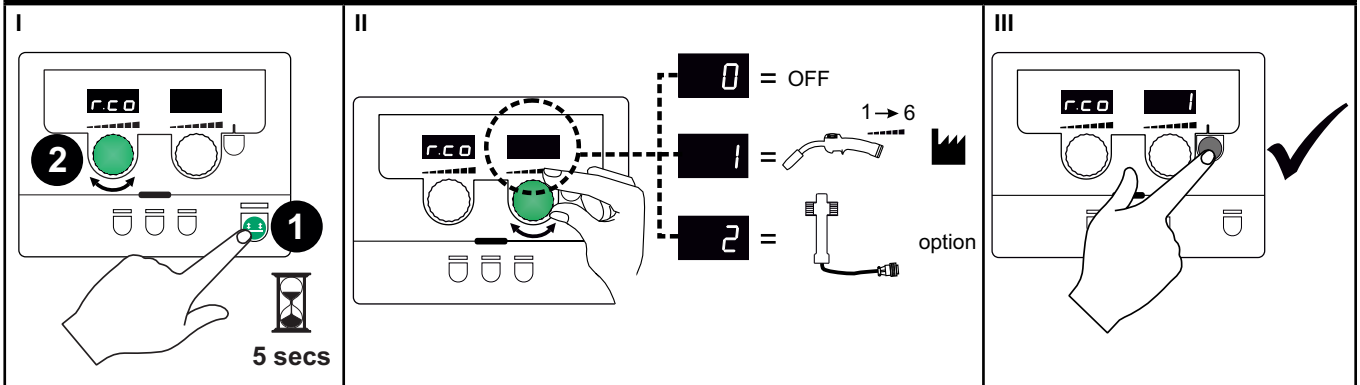

Fonction verrouillage /

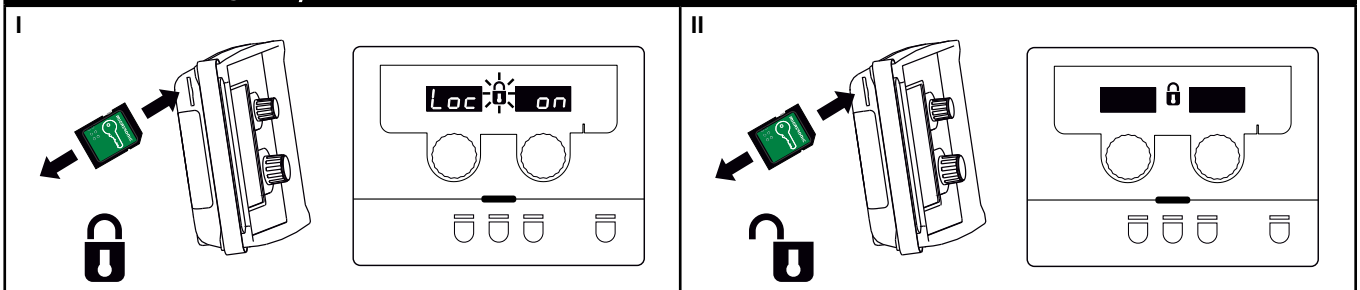

Réglage du débit de gaz (sur certains modèles uniquement)

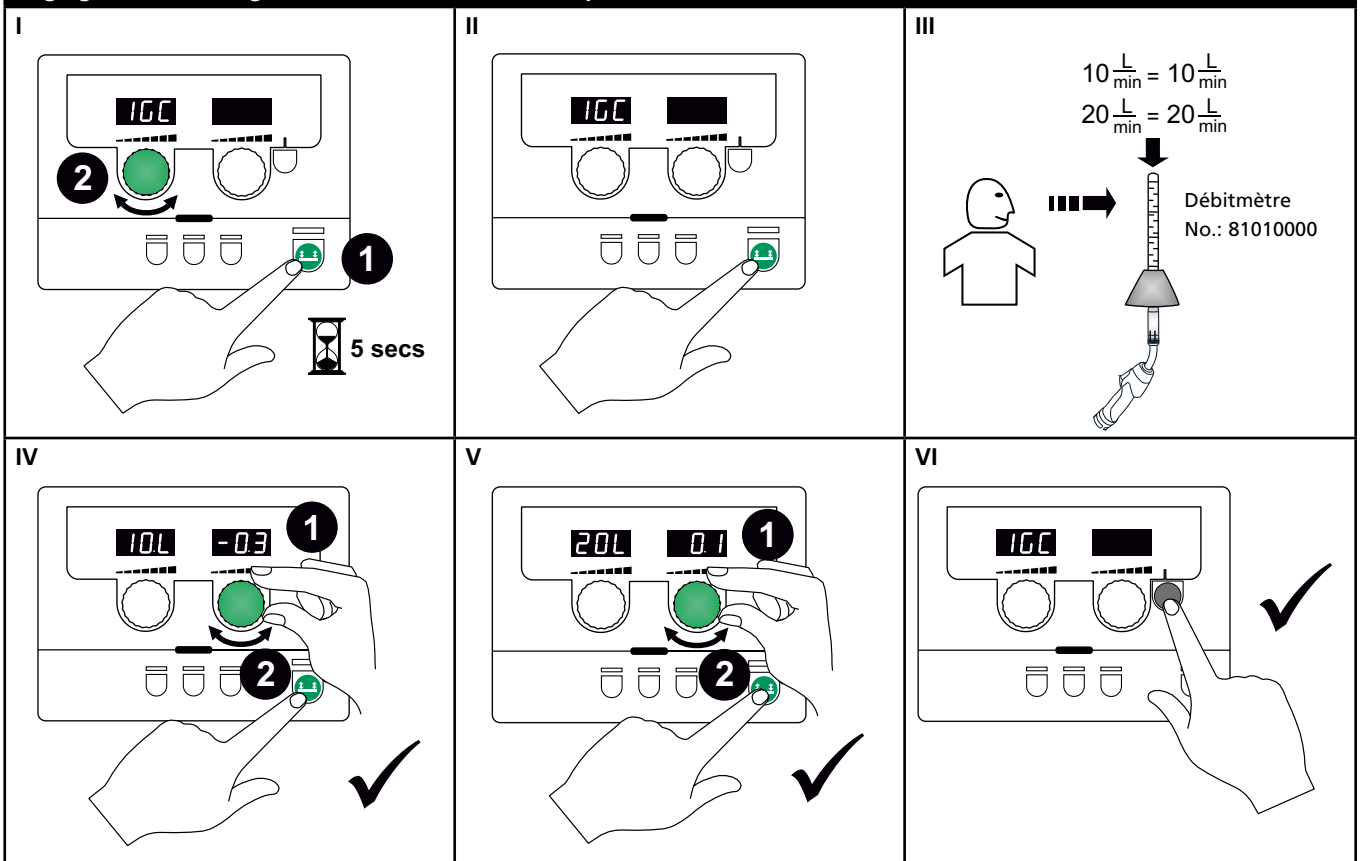

BASIC - Fonctions spéciales

Affichage de la version du logiciel/du numéro de licence

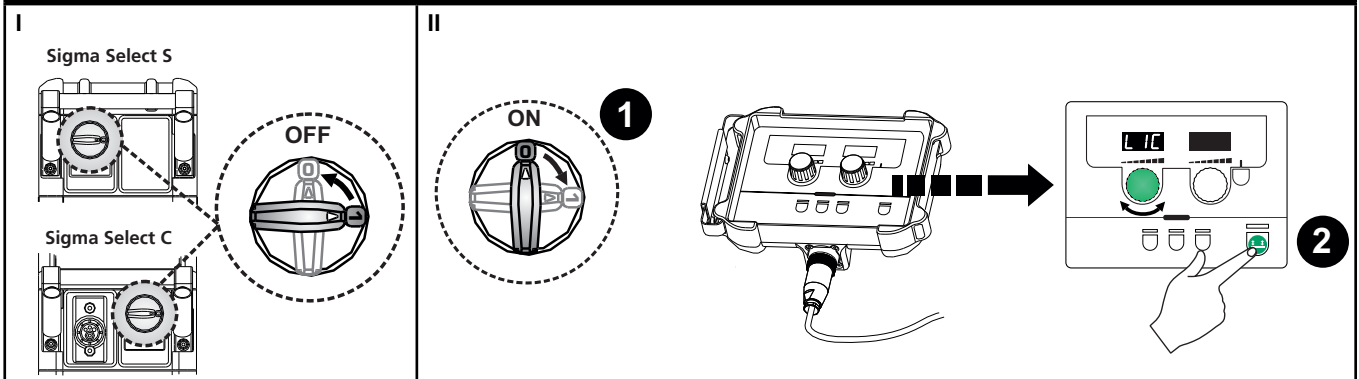

1. Numéro de licence

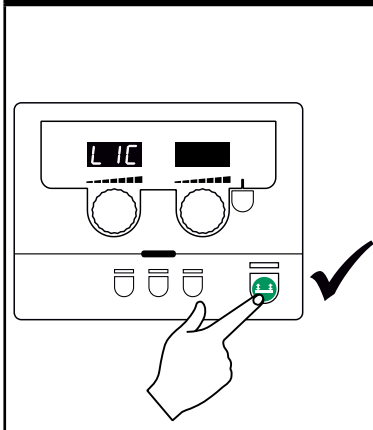

2. Noter le numéro de licence (12 chiffres)

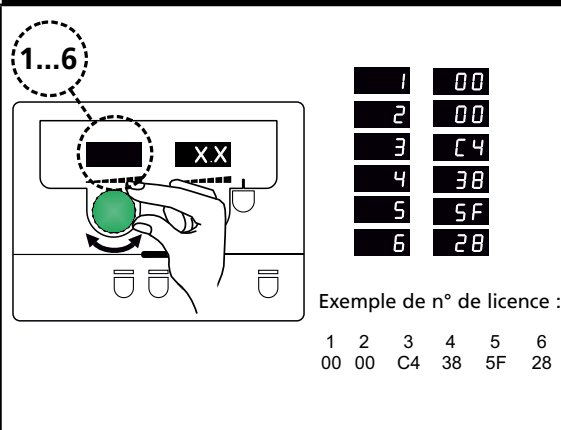

3. Revenir aux versions du logiciel

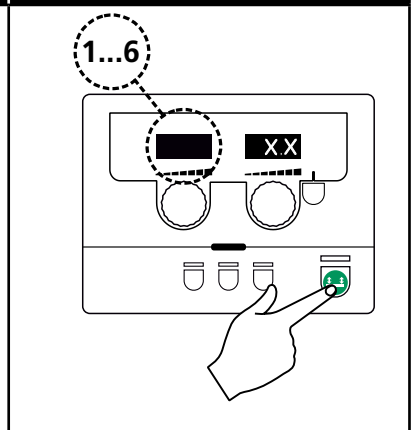

4. Sélectionner la version du logiciel

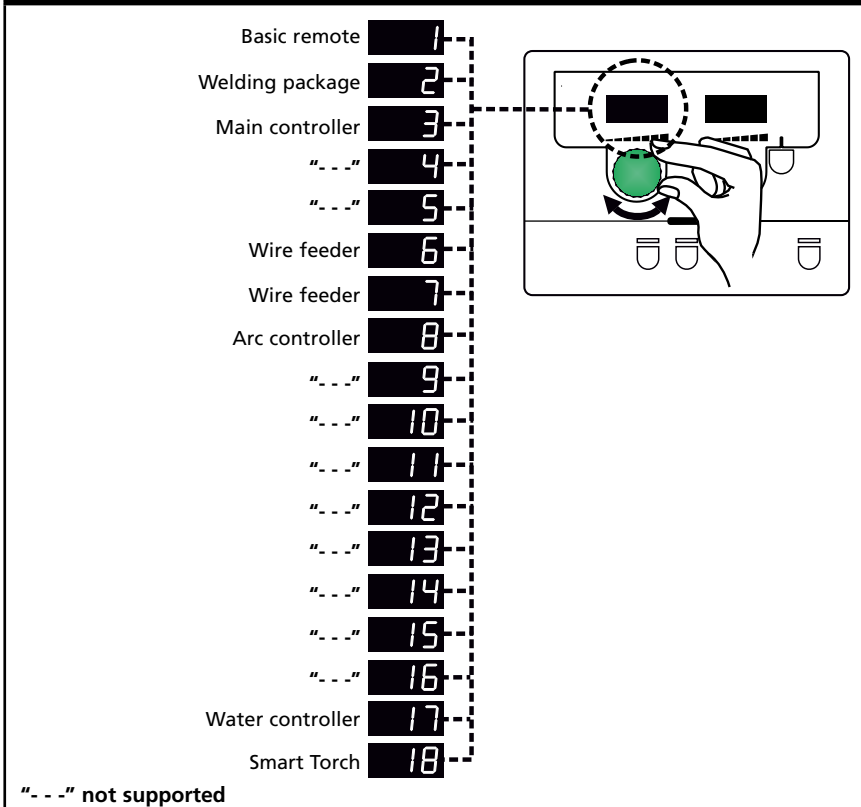

5. Quitter le menu

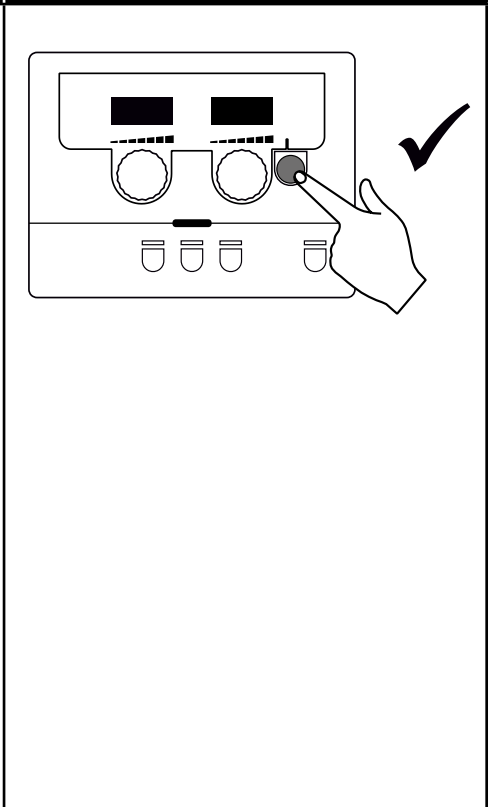

BASIC - Traitement des erreurs

Code	Problème et solution
E20-00	Il n'y a pas de logiciel dans la machine
E20-02	Télécharger le logiciel sur la carte SD. Insérer la carte SD dans l'unité de commande et allumer la machine. Remplacer la carte SD si nécessaire.
E21-00	
E21-06	
E21-08	
E20-01	La carte SD n'est pas formatée
E21-01	La carte doit être formatée en tant que FAT et le logiciel doit être téléchargé sur la carte SD. Remplacer la carte SD si nécessaire.
E20-03	La carte SD contient plusieurs fichiers du même nom
E21-02	Supprimer les fichiers de la carte SD et recharger le logiciel.
E20-04	L'espace disponible est insuffisant
	Réinsérer ou remplacer la carte SD. Contacter le SAV de MIGATRONIC si le problème persiste.
E20-05	Les logiciels de la carte SD ne correspondent pas à l'unité de commande utilisée
E20-06	Utiliser une carte SD contenant des logiciels compatibles avec l'unité de commande.
E20-07	La protection de copie interne ne permet pas l'accès au microprocesseur
	Réinsérer la carte SD ou contacter le SAV de MIGATRONIC si le problème persiste.
E20-08	L'unité de commande est défectueuse
E20-09	
E21-05	Contactez le SAV de MIGATRONIC.
E20-10	Le fichier chargé est défectueux
E21-07	Réinsérer ou remplacer la carte SD.
E21-03	Les programmes de soudage ne correspondent pas à l'unité de commande utilisée
E21-04	Utiliser une carte SD contenant des logiciels compatibles avec l'unité de commande.
Err GAS	Erreur de gaz Vérifier l'alimentation en gaz. Annuler l'erreur en appuyant brièvement sur n'importe quelle touche.
E02-04	Erreur de communication CAN Vérifier le câble/la prise intermédiaire.
E11-20	Erreur de l'ampèremètre 1. Vérifier l'ampèremètre. 2. Contacter le SAV de MIGATRONIC.

Symboles d'erreur

Défaut température

Le voyant de surchauffe s'allume si le soudage est interrompu en raison d'une surchauffe de la machine. Laisser la machine allumée jusqu'à ce que le ventilateur intégré l'ait refroidie.

Défaut courant

L'indicateur clignote si le courant de départ ou de soudage est supérieur à celui autorisé par le rendement de la machine. Assurez-vous que la vitesse du fil/le courant et la tension sont correctement paramétrés.

Symboles d'erreur

L'indicateur clignote en cas d'apparition d'autres types d'erreur. Parallèlement à ce clignotement, un code d'erreur s'affiche à l'écran.

Codes erreurs

E11 15 Défaut secteur

L'icône sera affichée si la tension du secteur est trop élevée. Reliez la machine à une alimentation 400V CA, +/-15% 50-60Hz.

Err H2O Défaut refroidissement torche

Un défaut de refroidissement est signalé lorsque le volume de liquide de refroidissement en circulation est insuffisant, en raison d'un problème de raccordement, de pièces défectueuses ou d'une obstruction. Contrôler si les tuyaux du système de refroidissement sont correctement branchés, compléter le niveau d'eau du réservoir et vérifier la torche de soudage et les branchements.

Si la viscosité du liquide de refroidissement est réduite en raison des basses températures, le liquide de refroidissement standard doit être remplacé par le 99290515 BTC-20 NF, qui se caractérise par sa conductibilité extrêmement faible et sa haute viscosité jusqu'à des températures de -17°C. Rincez le système avant d'ajouter un nouveau type de liquide de refroidissement.



Cette erreur peut être annulée par une pression brève sur la touche .

Err GAS Erreur de gaz (IGC)

L'erreur de gaz est due à un débit trop grand ou trop faible.

S'assurer que le débit de gaz est supérieur à 2 bars et inférieur à 6 bars, soit l'équivalent de 5 l/min et de 27 l/min. Cette erreur peut être résolue en réglant le débit de gaz à 27 l/min et annulée en appuyant brièvement sur la touche .

Erreur amenée du fil

 **E01 00** ou  **E01 01**

L'icône sera affichée en cas de surcharge du moteur commandant l'arrivée du fil. Le moteur ou l'électrovanne peut présenter un défaut.

Autres types d'erreur

Si d'autres symboles d'erreur sont affichés à l'écran, la machine doit être arrêtée puis rallumée pour faire disparaître le symbole. Si le symbole d'erreur apparaît de manière répétée, procédez à la réparation du module d'alimentation. Contactez votre distributeur pour de plus amples informations sur le défaut en question.

Les codes d'erreur ci-dessous peuvent apparaître lorsque d'autres unités sont connectées à la machine :

 **E07 04** s'affiche en cas de perte de communication entre la source d'alimentation et la/les unité(s) connectée(s).

 **E07 05** s'affiche lorsque le contrôle du moteur ne fonctionne pas correctement.

 **E07 06** s'affiche lorsque le moteur est surchargé.

GRAPHICAL - Fonctions spéciales

Assistant de configuration

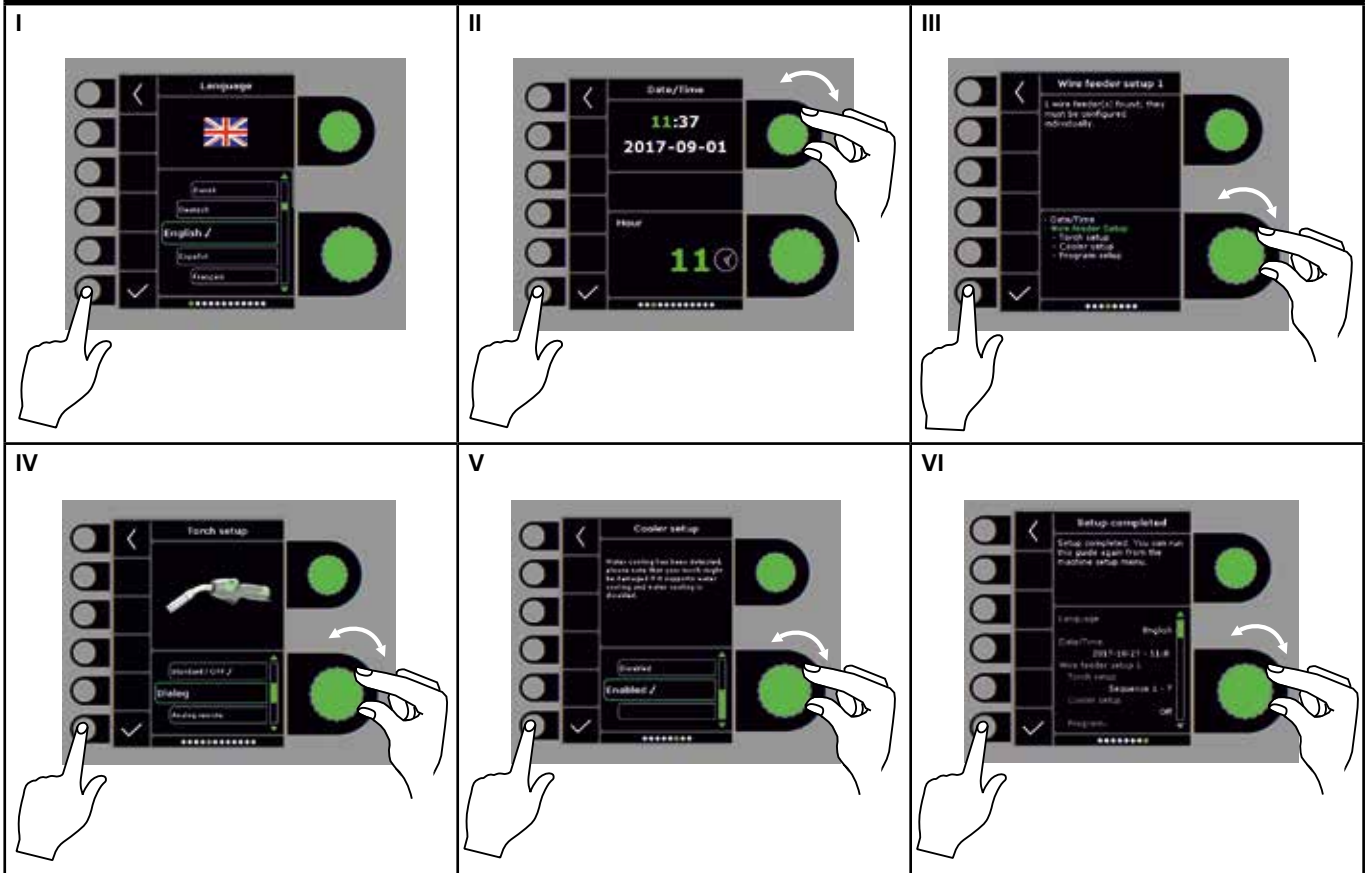

Fonction de verrouillage /

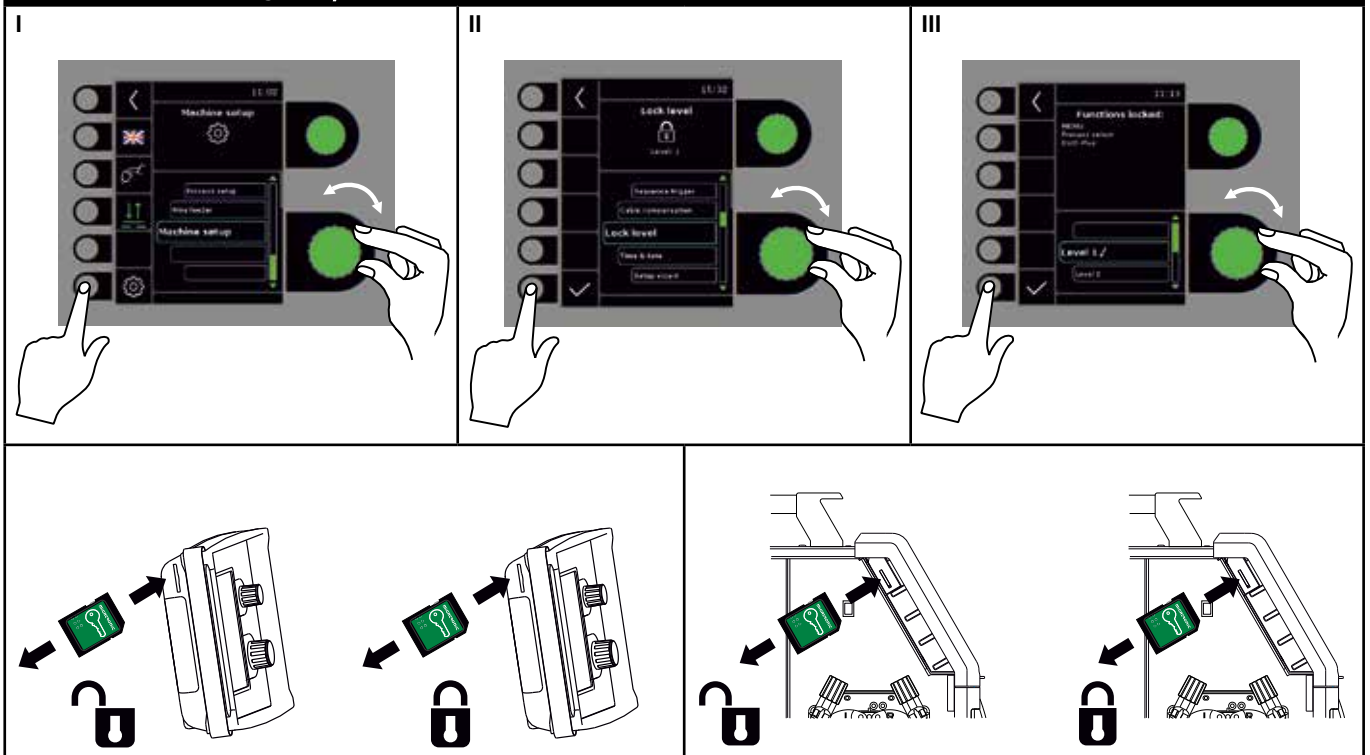

GRAPHICAL - Fonctions spéciales

Logiciel/licences

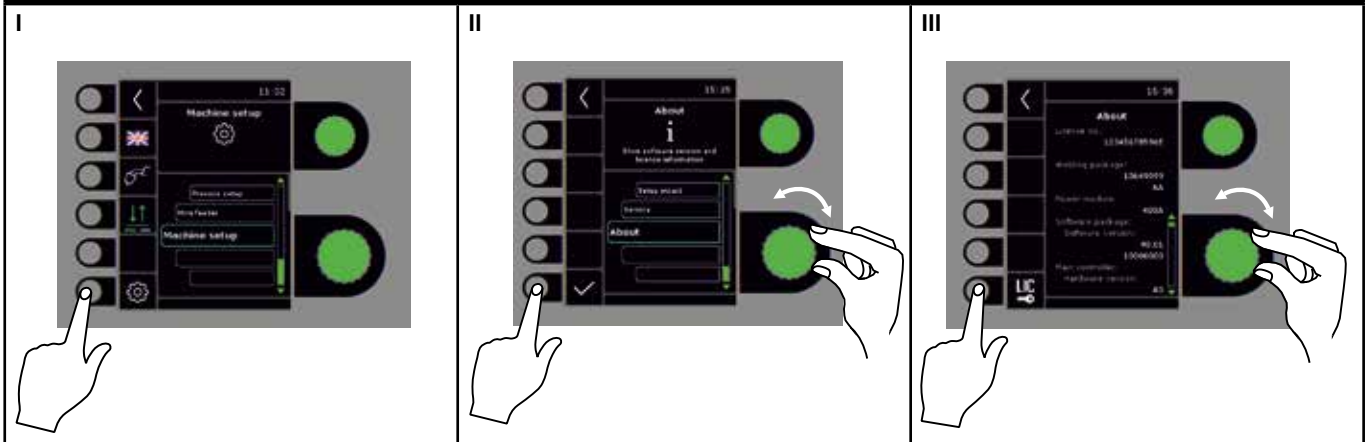

Compensation de câble (étalonnage de la résistance dans la torche de soudage)

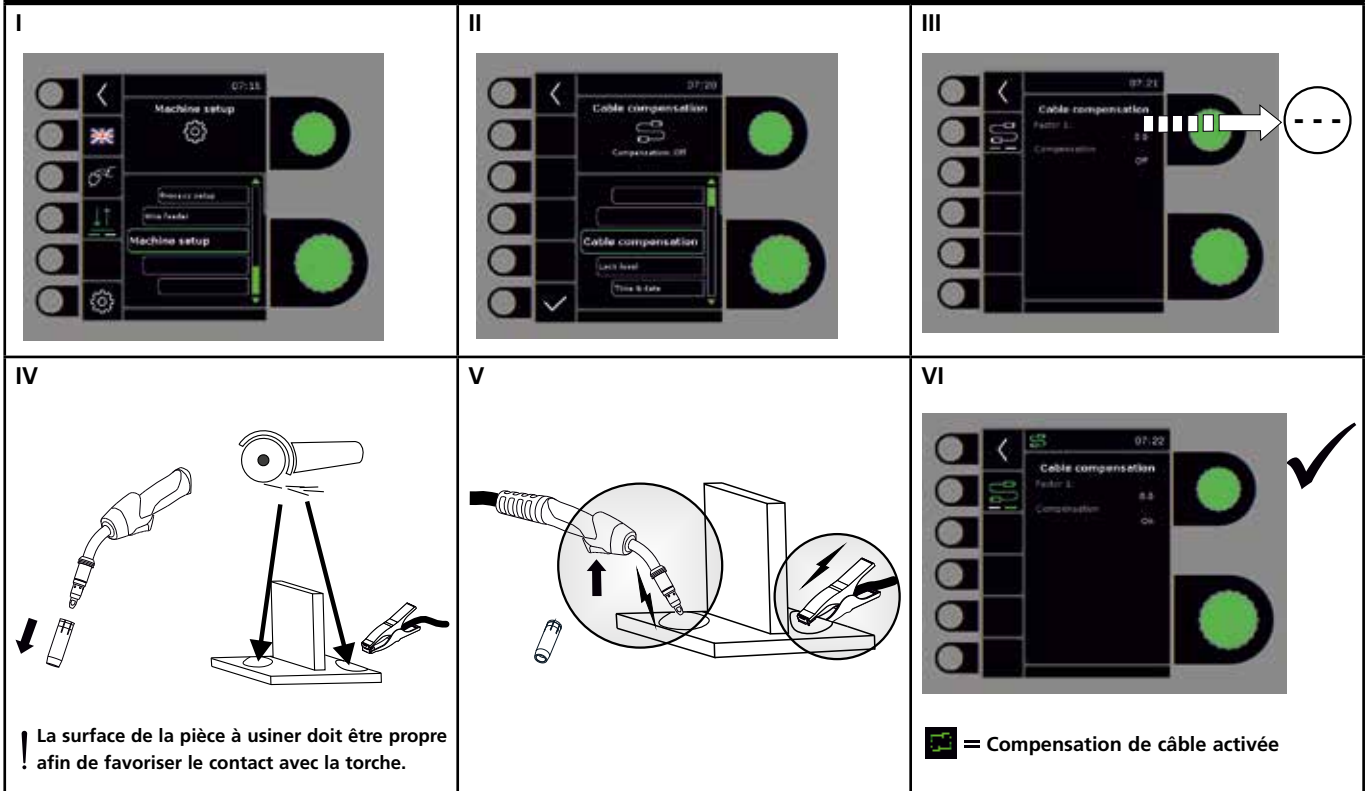

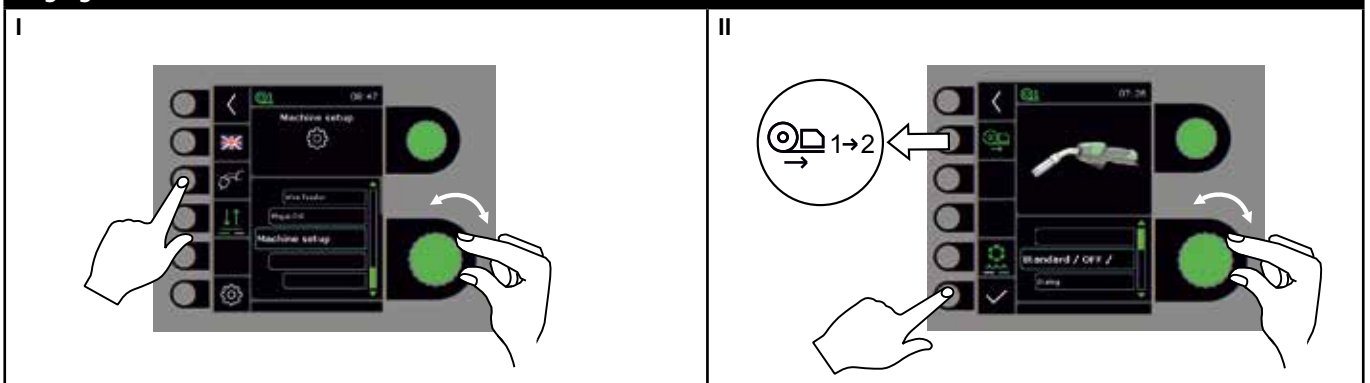

Réglage de la torche

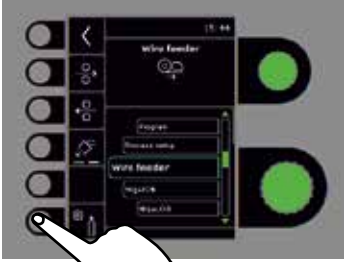

GRAPHICAL - Fonctions spéciales

Réglage du débit de gaz (sur certains modèles uniquement)

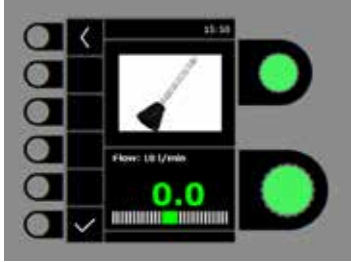
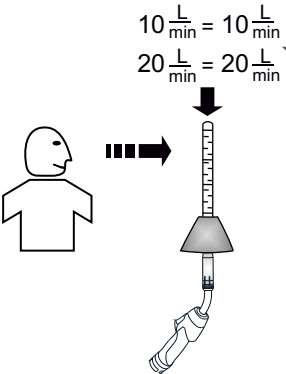
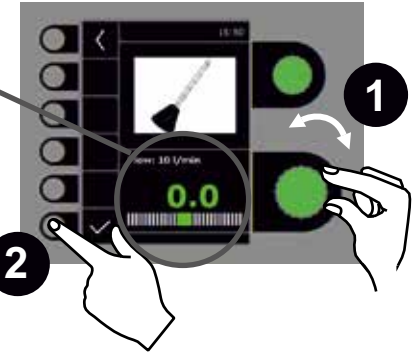
I 	II 	III 
IV 	V 	

GRAPHICAL - Traitement des erreurs

SIGMA Select dispose d'un système d'autoprotection intégré sophistiqué. La machine coupe automatiquement l'alimentation en gaz, le courant de soudage et le dévidage du fil en cas d'erreur.

Exemples d'erreurs :

Défaut refroidissement torche

Un défaut de refroidissement est signalé lorsque le volume de liquide de refroidissement en circulation est insuffisant, en raison d'un problème de raccordement, de pièces défectueuses ou d'une obstruction. Contrôler si les tuyaux du système de refroidissement sont correctement branchés, compléter le niveau d'eau du réservoir et vérifier la torche de soudage et les branchements.



Si la viscosité du liquide de refroidissement est réduite en raison des basses températures, le liquide de refroidissement standard doit être remplacé par le 99290515 BTC-20 NF, qui se caractérise par sa conductivité extrêmement faible et sa haute viscosité jusqu'à des températures de -17°C. Rincez le système avant d'ajouter un nouveau type de liquide de refroidissement.

Cette erreur peut être annulée par une pression brève sur la touche ✓.

Erreur de gaz (IGC)

L'erreur de gaz est due à un débit trop grand ou trop faible. S'assurer que le débit de gaz est supérieur à 2 bars et inférieur à 6 bars, soit l'équivalent de 5 l/min et de 27 l/min. Cette erreur peut être résolue en réglant le débit de gaz à 27 l/min et annulée en appuyant brièvement sur la touche ✓.

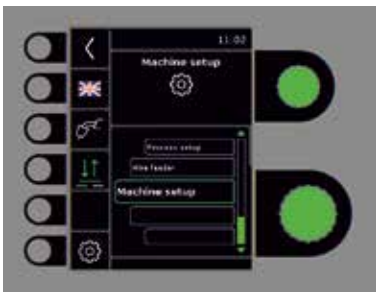
Remarque : il est important que l'alimentation en gaz indiquée puisse être maintenue pendant le soudage.

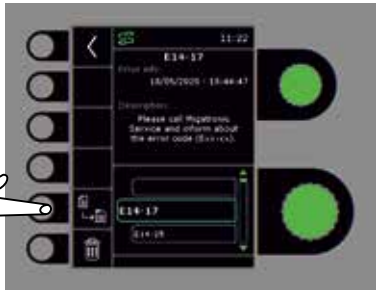
Journal des erreurs		
<p>I</p> 	<p>II</p> 	<p>III</p> 
<p>IV</p> <p>Journal des erreurs</p> <p>Toutes les erreurs sont enregistrées dans un journal accessible dans le menu Service. Le journal des erreurs peut être diffusé en insérant une carte SD et en appuyant sur la touche suivante : Le journal des erreurs est alors enregistré sur la carte SD. Le contenu du journal peut être effacé par une pression sur la touche de suppression (icône représentant une poubelle).</p>		

Caracteristiques techniques 1

MODULE d'ALIMENTATION SIGMA Select	300		300 IAC		400		400 IAC		550	
Tension de secteur $\pm 15\%$ (50-60Hz), V	3x400		3x400		3x400		3x400		3x400	
Taille minimale du générateur, kVA	16		19		27		29		40	
¹ Puissance de court-circuit minimale S _{sc} , MVA	3,7		4,3		6,0		6,0		9,5	
Fusible, A	16		16		20		20		35	
Courant secteur efficace, A	11,0		16,0		17,5		16,5		27,2	
Courant secteur max., A	15,4		18,3		26,0		28,2		39,2	
Puissance nominale, kVA	9,0		11,1		12,1		11,4		18,9	
Puissance max., kVA	10,7		12,7		18,0		19,5		27,1	
Puissance circuit ouvert, W	11		13		12		13		12	
Rendement, %	87		85		89		85		90	
Facteur de puissance	0,90		0,90		0,90		0,90		0,90	
	MIG	MMA	MIG	MMA	MIG	MMA	MIG	MMA	MIG	MMA
Plage du courant, A	15-300	15-250	15-300	15-300	15-400	15-400	15-400	15-400	15-550	15-550
Facteur de marche 100% 20°C, A	290/28,5	250/30,0	300/29,0	300/32,0	345/31,5	345/33,8	310/29,5	310/32,5	475/37,8	475/39,0
Facteur de marche max. 20°C, A/%V					400/65/34,0	400/65/36,0	400/60/34,0	400/60/36,0	550/60/41,5	550/60/42,0
Facteur de marche 100% 40°C, A/V	220/25,0	220/28,8	270/27,5	270/30,8	300/29,0	300/32,0	280/28,0	280/31,2	430/35,5	430/37,2
Facteur de marche 60% 40°C, A/V	240/26,0	230/29,2			370/32,5	370/34,8	350/31,5	350/34,0	510/39,5	510/40,4
Facteur de marche max. 40°C, A/%V	300/25/29,0	250/40/30,0	300/80/29,0	300/80/32,0	400/50/34,0	400/45/36,0	400/40/34,0	400/40/36,0	550/50/41,5	550/50/42,0
Tension à vide, V	50-60		65-70		65-70		65-70		75-80	
² Classe d'utilisation, C // S	S/CE // S/CE		S/CE // S/CE		S/CE // S/CE		S/CE // S/CE		S/CE // S/CE	
³ Classe de protection	IP23S		IP23		IP23		IP23		IP23	
Normes, C	IEC60974-1, IEC60974-5, IEC60974-10 Cl. A									
Normes, S	IEC60974-1, IEC60974-10 Cl. A									
Dimensions C (hxlaxlo), mm	700x260x735		700x260x735		700x260x735		700x260x735		700x260x735	
Dimensions S (hxlaxlo), mm	454x260x735		454x260x735		454x260x735		454x260x735		454x260x735	
Poids C / S, kg	36,9 / 26		53 / 36		52 / 35		53 / 36		53 / 36	

MODULE d'ALIMENTATION SIGMA Select	300 Boost				300 IAC Boost			
Tension de secteur $\pm 10\%$ (50-60Hz), V	3x208-380				3x380-440			
Taille minimale du générateur, kVA	16				25			
¹ Puissance de court-circuit minimale S _{sc} , MVA	1,7				3,75			
Fusible, A	20				16			
Courant secteur efficace, A	19,5				10,6			
Courant secteur max., A	31,6				16,2			
Puissance nominale, kVA	7,1				7,0			
Puissance max., kVA	11,0				10,6			
Puissance circuit ouvert, W	45				16			
Rendement, %	82				87			
Facteur de puissance	0,95				0,95			
	MIG	MMA	MIG	MMA	MIG	MMA	MIG	MMA
Plage du courant, A	15-300	15-250	15-300	15-250	15-300	15-300	15-300	15-300
Facteur de marche 100% 20°C, A	250/26,5		250/26,5		300/29,0	300/32,0	300/29,0	300/32,0
Facteur de marche max. 20°C, A/%V	300/40/29,0		300/40/29,0					
Facteur de marche 100% 40°C, A/V	200/24,0	200/28,0	200/24,0	200/28,0	250/26,5	220/28,8	250/26,5	220/28,8
Facteur de marche 60% 40°C, A/V	210/24,5	210/28,4	210/24,5	210/28,4	270/27,5	250/30,0	270/27,5	250/30,0
Facteur de marche max. 40°C, A/%V	300/25/29,0	250/35/30,0	300/25/29,0	250/35/30,0	300/35/29,0	300/30/32,0	300/35/29,0	300/30/32,0
Tension à vide, V	50-60				70-75			
² Classe d'utilisation, C // S	S/CE // S/CE				S/CE // S/CE			
³ Classe de protection	IP23S				IP23			
Normes, C	IEC60974-1, IEC60974-5, IEC60974-10 Cl. A							
Normes, S	IEC60974-1, IEC60974-10 Cl. A							
Dimensions C (hxlaxlo), mm	700x260x735				900x260x735			
Dimensions S (hxlaxlo), mm	454x260x735				654x260x735			
Poids C / S, kg	45 / 34				66 / 49			

- Cet équipement est conforme à la norme EN / IEC61000-3-12:2014 (/ 2011), à condition que la puissance de court-circuit S_{sc} du réseau au point de service soit supérieure ou égale aux données figurant dans le tableau ci-dessus. Il incombe à l'installateur ou à l'utilisateur de l'équipement de vérifier, en consultant l'opérateur du réseau de distribution si nécessaire, que la puissance de court-circuit S_{sc} délivrée est supérieure ou égale aux données figurant dans le tableau ci-dessus.
- S** Cette machine est conforme aux normes exigées pour les machines fonctionnant dans des zones à risque élevé de choc électrique.
- La machine est conçue pour une utilisation intérieure et extérieure selon les classes de protection IP23 et IP23S.
IP23S : La machine peut être entreposée mais n'est pas destinée à être utilisée à l'extérieur pendant les précipitations à moins d'être abritée

Caracteristiques techniques 2

MODULE d'ALIMENTATION SIGMA Select	400 Boost				400 IAC Boost			
Tension de secteur ±10% (50-60Hz), V	3x208-380		3x380-440		3x208-380		3x380-440	
Taille minimale du générateur, kVA	25		25		25		25	
¹⁾ Puissance de court-circuit minimale S _{sc} , MVA					4,0		4,0	
Fusible, A	25-50		25-50		25-50		25-50	
Courant secteur efficace, A	22,0		11,7		24,8		11,8	
Courant secteur max., A	45,0		23,5		48,0		24,5	
Puissance nominale, kVA	8,3		8,1		8,5		8,5	
Puissance max., kVA	16,7		16,3		17,4		17,4	
Puissance circuit ouvert, W	60		56		60		71	
Rendement, %	84		88		82		85	
Facteur de puissance	0,96		0,95		0,96		0,96	
	MIG	MMA	MIG	MMA	MIG	MMA	MIG	MMA
Plage du courant, A	15-400	15-400	15-400	15-400	15-400	15-400	15-400	15-400
Facteur de marche 100% 20°C, A	300/29,0	300/32,0	300/29,0	300/32,0	300/29,0	300/32,0	300/29,0	300/32,0
Facteur de marche max. 20°C, A/%V	400/30/34,0	400/30/32,0	400/30/34,0	400/30/32,0	400/30/34,0	400/30/32,0	400/30/34,0	400/30/32,0
Facteur de marche 100% 40°C, A/V	250/26,5	220/28,8	250/26,5	220/28,8	250/26,5	220/28,8	250/26,5	220/28,8
Facteur de marche 60% 40°C, A/V	280/28,0	260/30,4	280/28,0	260/30,4	280/28,0	260/30,4	280/28,0	260/30,4
Facteur de marche max. 40°C, A/%V	400/25/34,0	400/20/36,0	400/25/34,0	400/20/36,0	400/25/34,0	400/20/36,0	400/25/34,0	400/20/36,0
Tension à vide, V	70-75				70-75			
²⁾ Classe d'utilisation, C // S	S/CE // S/CE				S/CE // S/CE			
³⁾ Classe de protection	IP23				IP23			
Normes, C	IEC60974-1, IEC60974-5, IEC60974-10 Cl. A				IEC60974-1, IEC60974-5, IEC60974-10 Cl. A			
Normes, S	IEC60974-1, IEC60974-10 Cl. A				IEC60974-1, IEC60974-10 Cl. A			
Dimensions C (hxlaxlo), mm	900x260x735				900x260x735			
Dimensions S (hxlaxlo), mm	654x260x735				654x260x735			
Poids C / S, kg	66 / 49				67 / 50			

DÉVIDOIR MWF			
Vitesse de dévidage, m/min	0,5-30,0		
Raccord de la torche	EURO		
Diamètre bobine, mm	300		
Bobine, kg	5-18		
Facteur de marche 100 % 40°C, A	430		
Facteur de marche 60% 40°C, A	500		
Facteur de marche max. 40°C, A/%	550/50		
³⁾ Classe de protection	IP23		
Diamètre de fil, mm	0,6-1,6		
Pression du gaz, MPa (bar)	0,6 (6,0)		
	MWF 30	MWF 32	MWF 33
Dimensions (hxlaxlo), mm	413x310x750	457x260x672,5	457x260x672,5
Poids, kg	11,6	14,0	14,0
Normes	IEC60974-5, IEC60974-10 CL. A		

MODULE DE REFROIDISSEMENT MCU 1300	
Capacité de refroidissement (1 l/min), W	1300
Capacité de refroidissement (1,5 l/min), W	1600
Contenance du réservoir, litres	5
Débit, bar - °C - l/min	3,0-60-1,5
Pression max., bar	5
Normes	IEC60974-2, IEC60974-10 CL.A
Dimensions (hxlaxlo), mm	207x260x680
Poids	20

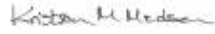
CERTIFICAT DE CONFORMITE CE
 MIGATRONIC A/S Aggersundvej 33 9690 Fjerritslev Danemark
déclarons par la présente que notre machine portant les références ci-dessous
Type: SIGMA Select
respecte les directives : 2014/35/EU 2014/30/EU 2011/65/EU
Normes européennes : EN IEC60974-1:2018/A1:2019 EN IEC60974-2:2019 EN IEC60974-5:2019 EN / IEC60974-10:2014/A1:2015
Réglementation : 2019/1784/EU
Fait à Fjerritslev, 10.02.2021
 Kristian M. Madsen PDG

- Cet équipement est conforme à la norme EN / IEC61000-3-12:2014 (/ 2011), à condition que la puissance de court-circuit S_{sc} du réseau au point de service soit supérieure ou égale aux données figurant dans le tableau ci-dessus. Il incombe à l'installateur ou à l'utilisateur de l'équipement de vérifier, en consultant l'opérateur du réseau de distribution si nécessaire, que la puissance de court-circuit S_{sc} délivrée est supérieure ou égale aux données figurant dans le tableau ci-dessus.
- S** Cette machine est conforme aux normes exigées pour les machines fonctionnant dans des zones à risque élevé de choc électrique.
- La machine est conçue pour une utilisation intérieure et extérieure selon les classes de protection IP23 et IP23S.
IP23S : La machine peut être entreposée mais n'est pas destinée à être utilisée à l'extérieur pendant les précipitations à moins d'être abritée

Anslutning och igångsättning

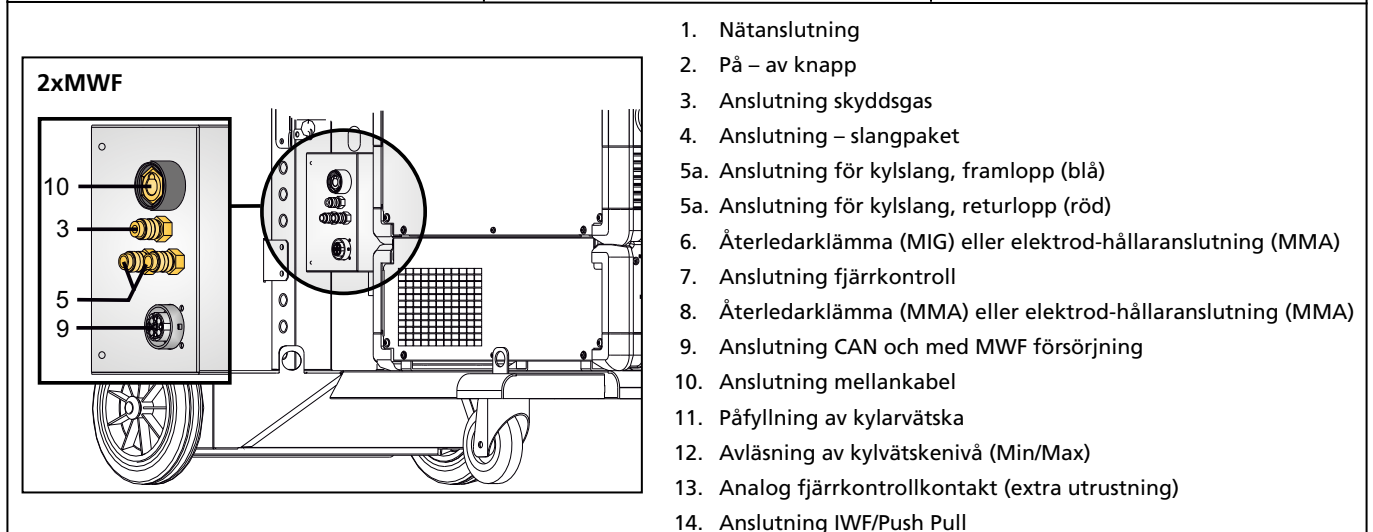
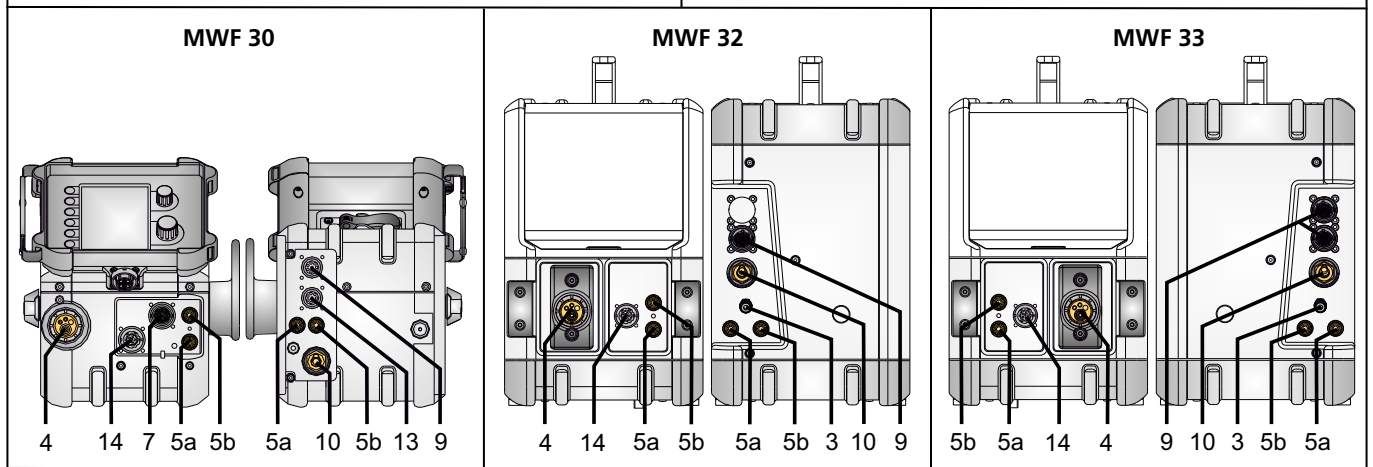
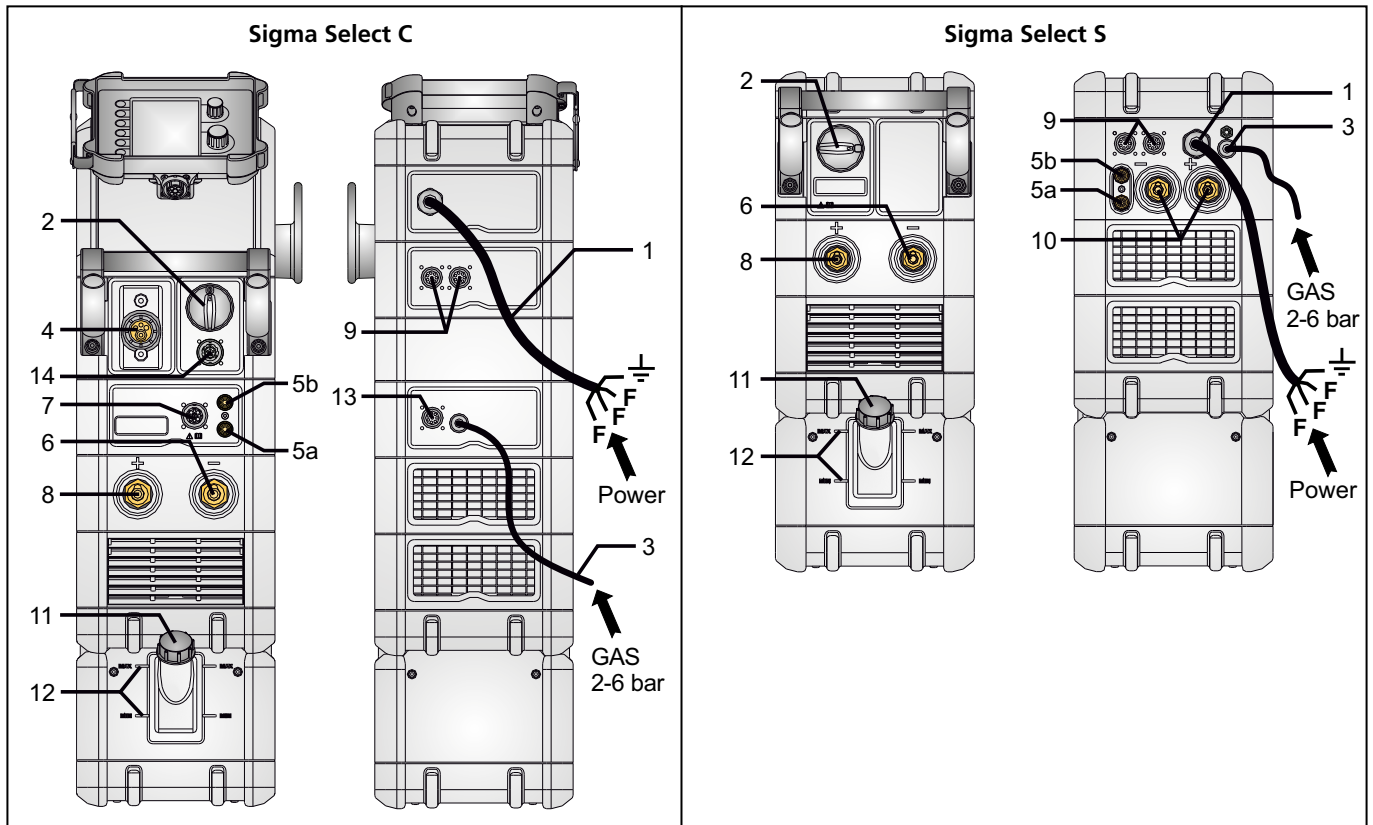

Anslutning och igångsättning



Varning

Läs varning och bruksanvisning noggrant innan installation och igångsättning och spara till senare bruk.

Installation

Nätanslutning

Anslut maskinen till den nätspänning den är konstruerad till. Se typskylt (U1) bak på maskinen.

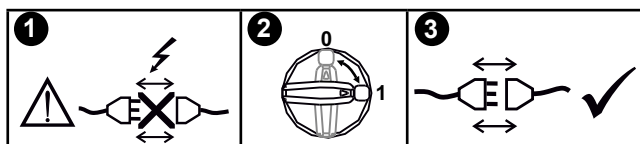
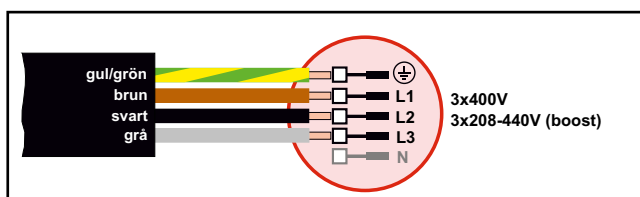

Stabiliseringskit

Strömkällan kan konfigureras med ett stabiliseringskit som skyddar mot större spänningsvariationer, t.ex. vid generatorbruk, där maskinen är inkopplad till separat nätförsörjning.

Anslutning av skyddsgas

Gaslangen, som utgår från baksidan av maskinen (3), ansluts till gasförsörjning med en reduceringsventil (2-6 bar).

(Obs. Några typer av reduceringsventiler kan kräva högre utgångstryck än 2 bar för att fungera optimalt).

En/två gasflaskor kan fixeras bak på vagnen.

Gasförbrukning

Beroende på svetsuppdrag, gastyp och svetssöm kan gasförbrukningen variera från 6-7 l/min. vid låga ampere (<25A) och upp till 27 l/min. vid max. ampere.

Materialförbrukning

Materialförbrukning kan beräknas genom att göra beräkningen svetsstid i minuter x trådhastighet (m/min) x vikt per meter på det aktuella tillsatsmaterialet.

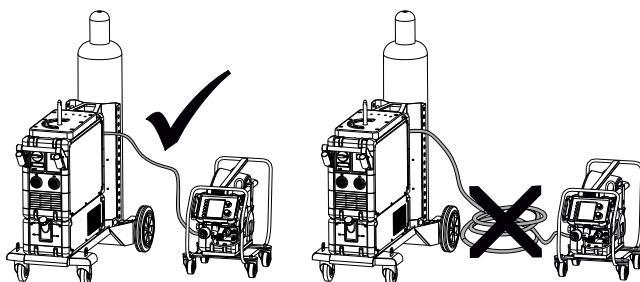

! VARNING

När man trycker på slangpaketets kontakt/avtryckare är det spänning på svetsstråden/elektroden.

Anslutning av slangpaket

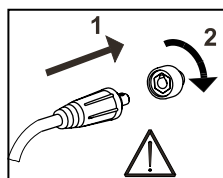
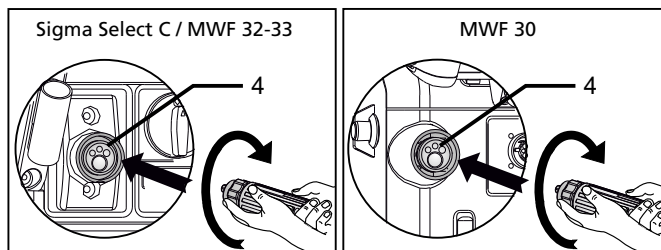

Viktigt!

När återledarkabel och slangpaket ansluts maskinen, är god elektrisk kontakt nödvändig, för att undgå att kontakter och kablar ödeläggs.

Anslutning av elektrodhållare för MMA

Elektrodhållare och återledarkabel ansluts plusuttag (10) och minusuttag (8). Polariteten väljes efter elektrodlieferantörens anvisning.

Rekommenderade kabelstorlekar

Svetsström	DC	PULS
200 A	35 mm ²	35 mm ²
300 A	50 mm ²	70 mm ²
400 A	95 mm ² / 2x50 mm ²	95 mm ² / 2x50 mm ²
550 A	2x70 mm ²	2x70 mm ²

Svetsprocess	Avstånd till arbetsämnet (a+b)	Total kabellängd i svetskretsloppet (a+b+c)
MIG - IAC och puls	10 m	20 m
MIG - ingen puls	30 m	60 m

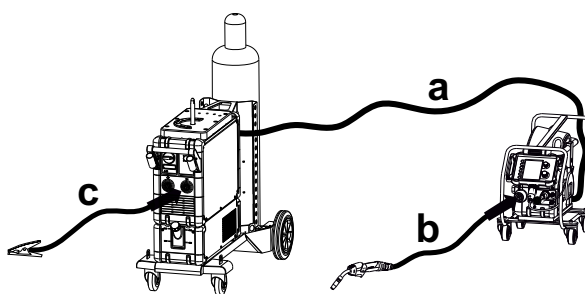

Justering av trådbroms

Bromsen justeras så stramt at trådrullen stannar innan svetsstråden kör ut över kanten på rullen. Bromskraften beror på trådrullens vikt och den trådhastigheten som används. Fabriksinställt till 15kg.

Justering:

- Avmontera vridknappen genom att sticka in en tunn skruvmejsel bakom knappen och bänd därefter loss knappen.
- Justera trådbromsen genom att spänna eller lossa lås-skraven på trådrullens axel.
- Montera vridknappen igen.

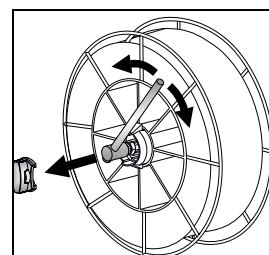

Anslutning och igångsättning

Lyftanvisning

När maskine eller MWF-enhet skall lyftas, skall lyftpunkterna, som visas på figuren, användas.

Maskinen får ej lyftas med monterad gasflaska!

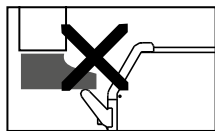
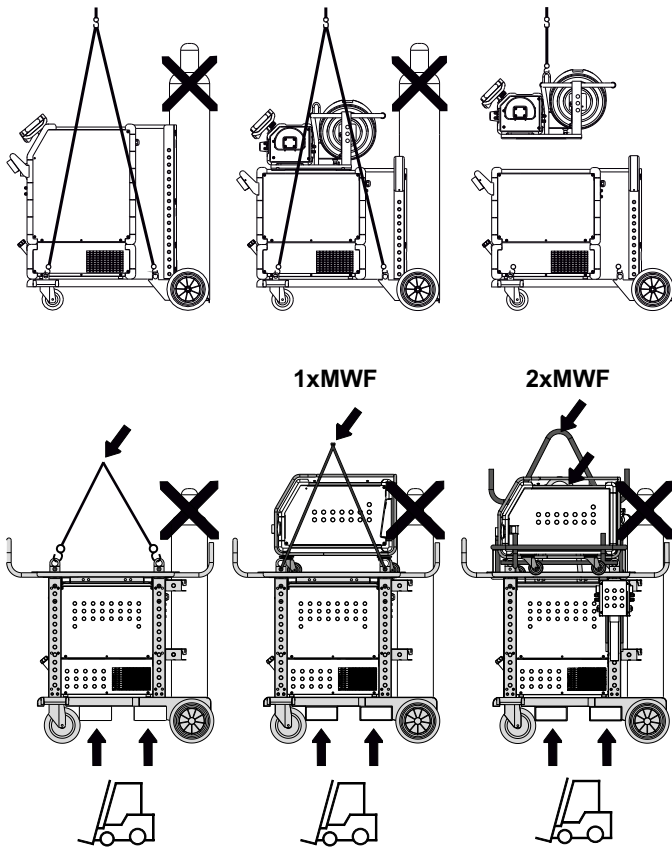

Lyft inte maskinen i handtaget.
Stå ej på handtaget.

Montering av fjärrkontroll

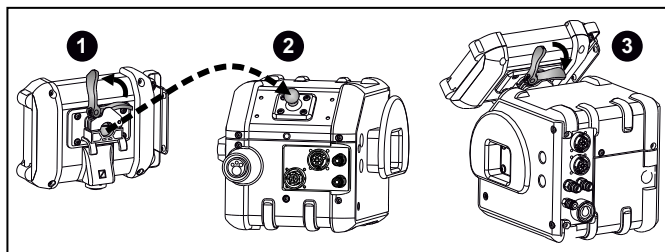

Kabelupphängning MWF 30

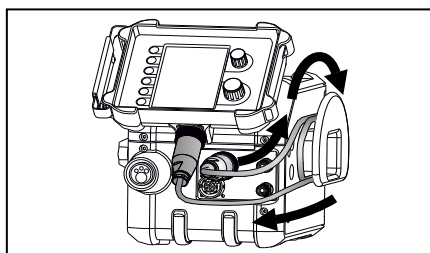

MCU utluftning

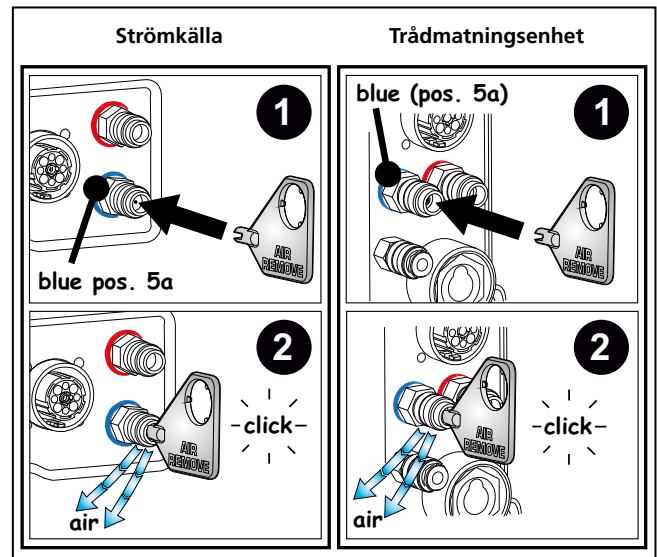

Lås- och vridfunktion MWF

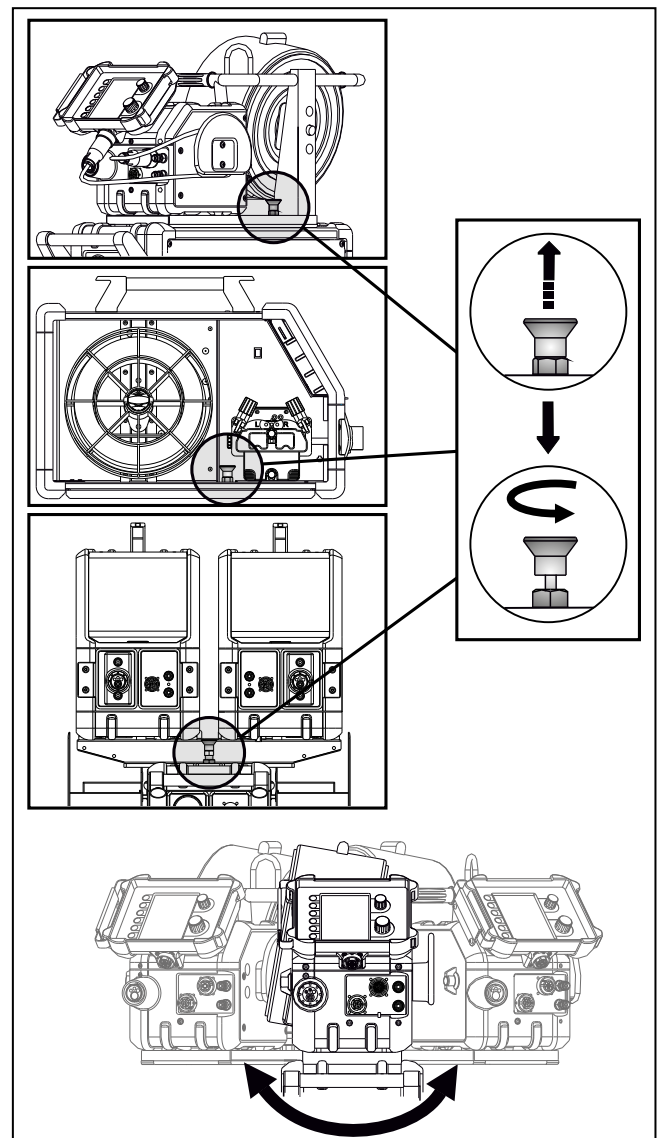

Anslutning och igångsättning

Montering av delar i trådmatningen

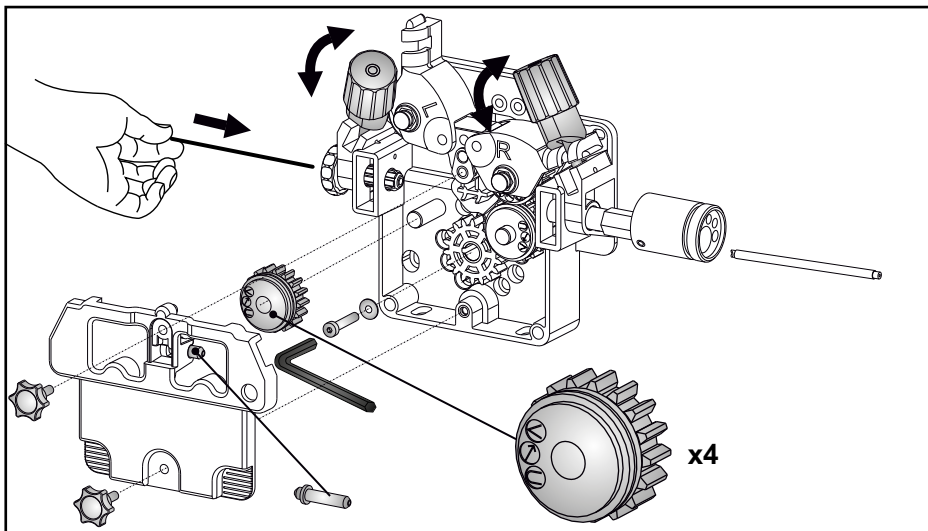

Fingerskruvens tryck ställs in, så att matarhjulen precis glider på tråden, när den bromsas vid kontaktdysan

Rangering av tråd fram/retur

När man inte svetsar, kan rangering av tråd startas genom ett tryck på en av knapparna eller från robotinterface, om MWF30 används i en robotlösning.

Rangering

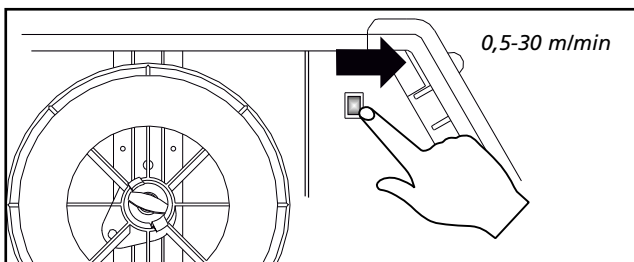

Rangering MWF 30

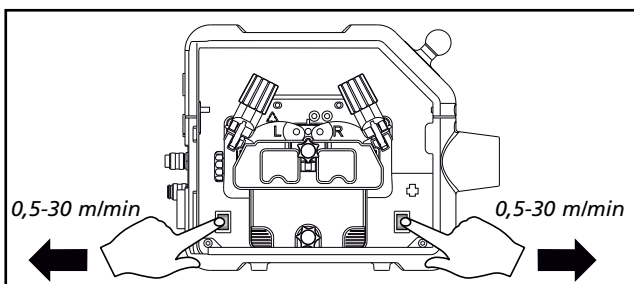

Rangering Graphical

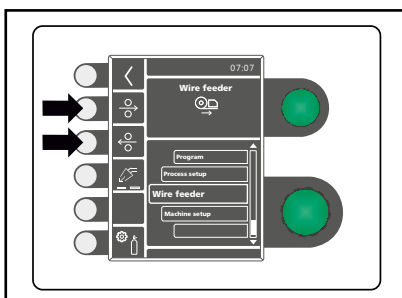

Software uppdatering

- Sätt i SD-kortet.
- Tänd maskinen.
- Vänta tills enheten indikerar, att uppdatering är avslutad.
- Släck maskinen och ta ut SD-kortet.
- Maskinen är nu klar för användning.

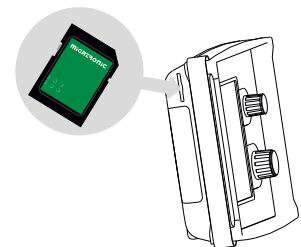

Strömkälla och alla inkopplade enheter får den nya software inläst.

Softwren kan downloadas från <http://migatron.com> till ett SD-kort. SD-kortets filsystem skall vara formaterat till FAT32.

VIKTIGT:

Software skall sparas i mappstrukturen: //MIGA_SW/SIGMA/

Licens SW

Vid tillköp av extra program eller särskilda funktioner skall MigaLic.data filerna läsas in på samma sätt som SW-packet. Kom ihåg att spara en säkerhetskopior av filerna.

MigaLic.txt filen innehåller information om maskinens licensnummer och de sparade licenserna på SD-kort.

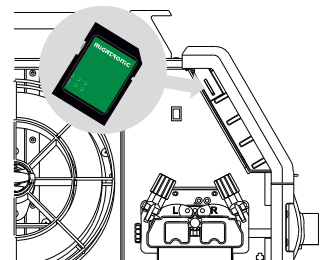

BASIC - Speciella funktioner

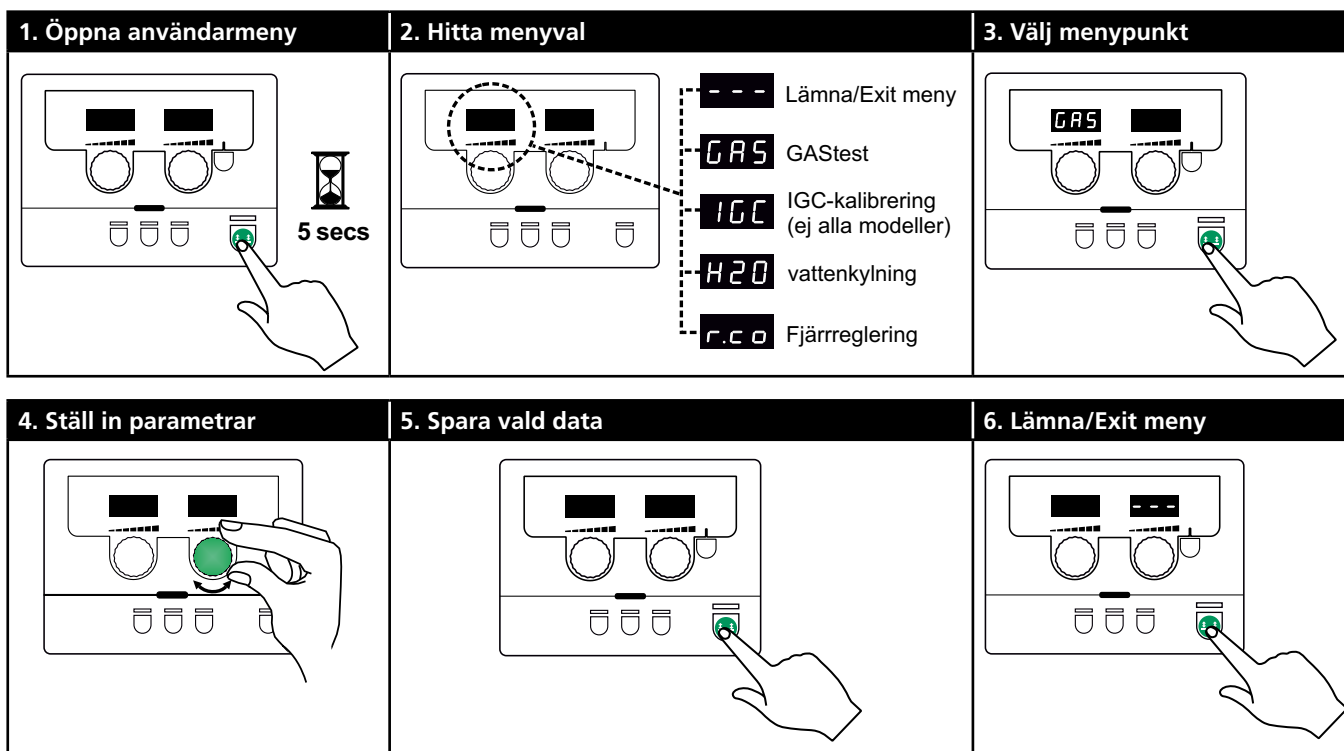

Parametrar och menyval

Användarmenyn öppnas med ett långt tryck på -knappen. Vrid på vänster vridknapp till det önskade menyvalet visas. Höger vridknapp kan användas till att ändra inställningar, som visas i höger display. Med ett kort tryck på -knappen aktiveras funktioner som t.ex. gastest.

Följande diagram visar alla funktioner och parametrar i användarmenyn.

--- **GAS** **IGC** **H2O** **r.c.o**

--- Lämna menyn om man trycker på -knappen.

GAS GAS test
Gasventilen öppnas och stängs -knappen.
Gasgenomströmningen kan ställas in med höger vridknapp, om IGC-kit är installerat.

IGC IGC-kalibrering
Endast synlig när IGC-kit är installerat.
IGC-kalibrering startas med -knappen.

H2O Vattenkylning
Endast synlig när kylmodul är installerat.

0: Vattenkylning OFF
1: Vattenkylning ON

r.c.o Inställning av fjärrreglering
Inställning kan ändras med höger vridknapp.

Följande inställningar understötts:

0: Inaktiv
1: Dialog-brännare (varunummer 80100402)
2: Analog fjärrreglering (varunummer 78815029)

BASIC - Speciella funktioner

Konfiguration av fjärrkontroll

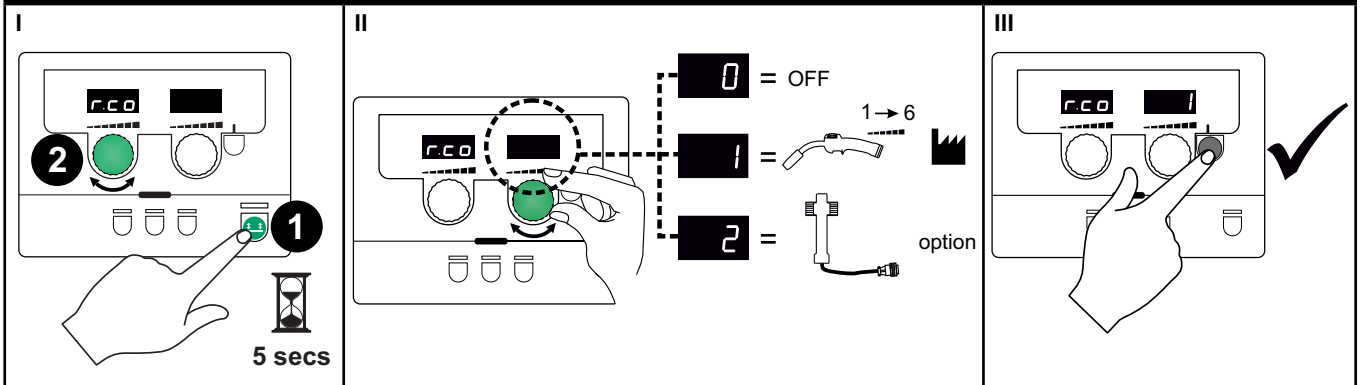

Låsfunktion /

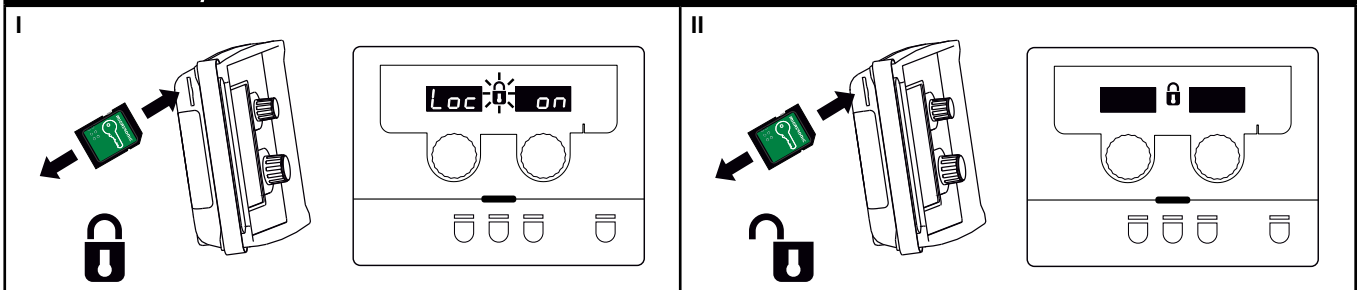

Kalibrering av gasflow (ej alla modeller)

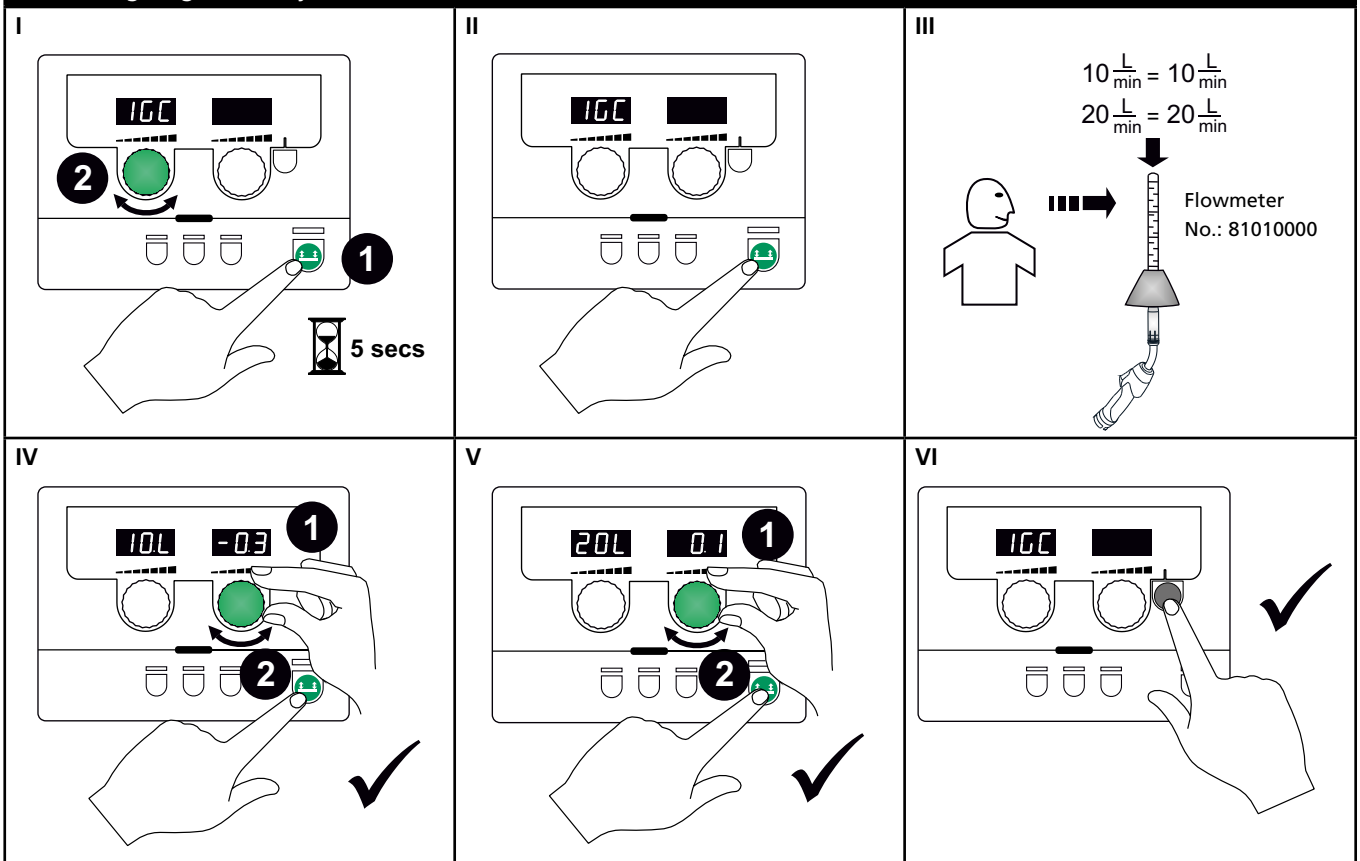

BASIC - Speciella funktioner

Visning av softwareversioner/licensnr.

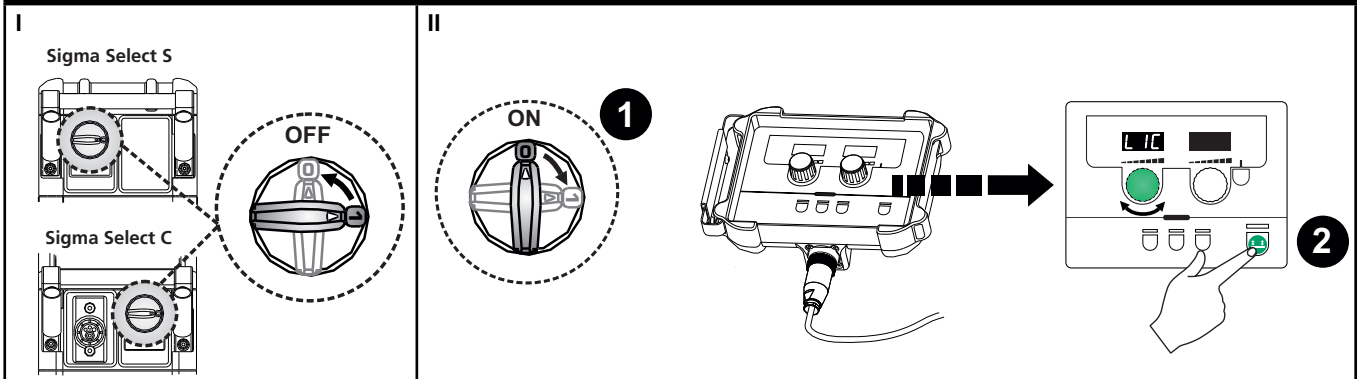

1. Licensnr.

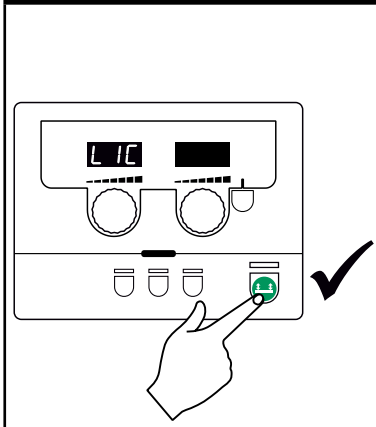

2. Se licensnr. (12 cifre)

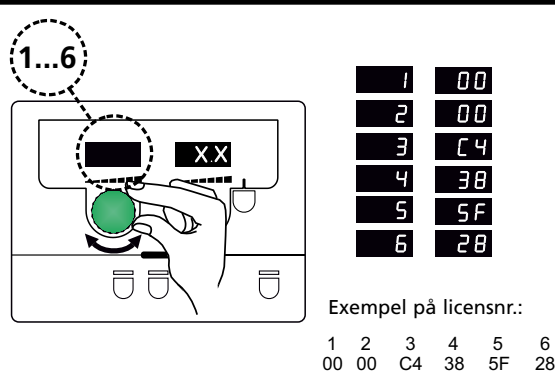

3. Retur till SW-versioner

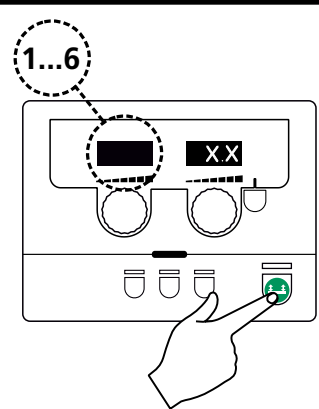

4. Välj SW

- Basic remote 1
- Welding package 2
- Main controller 3
- "-" 4
- "-" 5
- Wire feeder 6
- Wire feeder 7
- Arc controller 8
- "-" 9
- "-" 10
- "-" 11
- "-" 12
- "-" 13
- "-" 14
- "-" 15
- "-" 16
- Water controller 17
- Smart Torch 18

"-" not supported

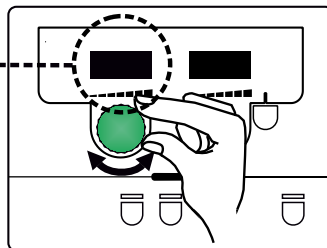

5. Lämna/Exit meny

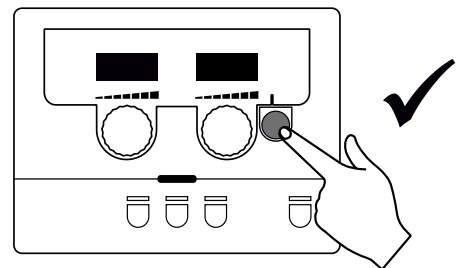

BASIC - Felhantering

Felkod	Orsak och åtgärd
E20-00	Det finns ingen software i kontrollboxen
E20-02	Download software till SD kortet, sätt SD kortet i boxen och tänd maskinen. Byt evt. ut SD kortet.
E21-00	
E21-06	
E21-08	
E20-01	SD kortet är ej formaterat
E21-01	Formatera SD kortet i en PC, som FAT och download software till SD kortet. Byt evt. ut SD kortet.
E20-03	SD kortet har flera filer med samme namn
E21-02	Ta bort SD kortet och download software igen.
E20-04	Kontroll boxen har försökt läsa in mer data än den kan ha i minnet Läs in SD kortet igen eller Byt ut SD kortet. Tillkalla MIGATRONIC Service, om problemet ej kan lösas.
E20-05	Software på SD kortet är låst till en annan typ av kontrollbox
E20-06	Använd ett SD kort med software som passar till din typ av kontrollbox.
E20-07	Det interna kopieringsskyddet tillåter ej åtgång till mikroprocessorn Läs in SD kortet i maskinen igen eller tillkalla MIGATRONIC Service.
E20-08	Kontrollboxen är defekt
E20-09	Tillkalla MIGATRONIC Service.
E21-05	
E20-10	Den inlästa filen är felaktig
E21-07	Läs in SD kortet igen eller byt ut SD kortet.
E21-03	Det svetsprogrampaket du försöker att läsa in passar ej till denna kontrollbox
E21-04	Använd ett SD kort med software som passar till din kontrollbox.
Err GAS	Gasfel Kontrollera gastillförseln Gasfel avregistreras med ett kort tryck på en valfri knapp.
E02-04	CAN – kommunikationsfel Kontrollera mellankabel/kontakt
E11-20	Strömsensorfel 1. Kontrollera strömsensor 2. Tillkalla MIGATRONIC Service

Felsymboler

Temperaturfel

Överhettningssymbolen lyser, om svetsningen blir avbruten på grund av överhettning av maskinen. Låt maskinen vara på tills den är avkyld av den inbyggda fläkten.



Strömfele

Indikatorn blinkar, när startströmmen eller svetsströmmen är högre än maskinens prestanda tillåter. Kontrollera att tråd hastighet/ström och spänning är korrekt inställt.

Visning av felkoder

Indikatorn blinkar, när andra typer av fel uppstår. Samtidigt visas felkoden i displayen.

Utvalda felkoder

Överspänningsfel

Ikonet visas, när nätspänningen är för hög. Anslut maskinen till 400V AC, +/-15% 50-60Hz.

Kylfel

Kylfel visas i händelse av att kylvattnet ej kan cirkulera till följd av felaktig anslutning eller tillstoppning. Kontrollera att kylslangarna är korrekt anslutna, fyll på vattenbehållaren och se över slangpaket och anslutningsrör. Om kylvätskans viskositet minskar på grund av låga temperaturer, skall Migatronic standard kylvätska bytas ut till 99290515 BTC 20 NF kylvätska, som kännetecknas av sin extremt låga ledningsförmåga och höga viskositet vid temperaturer ned till -17°C. Skölj igenom systemet innan påfyllning av ny typ av kylvätska. Kylfelen avanmäls med ett kort tryck på -knappen.

Gasfel (IGC)

Gasfel kan bero på för lågt eller för högt tryck på gastillförseln. Kontrollera att trycket på gastillförseln är högre än 2 bar och mindre än 6 bar, svarande till 5 l/min och 27 l/min. Gasfel kan kopplas ur funktion genom att ställa in manuell gasflow på 27 l/min. Gasfelen avanmäls med ett kort tryck på -knappen.

Trädfel

eller

Ikonet tänds vid överbelastad trådmatningsmotor. Trådmotorn eller magnetventilen kan vara defekt.

Andra feltyper

Om andra felkoder visas i displayen skall maskinen stängas av och tändas för att avlägsna meddelandet.

Om felmeddelandet ständigt återkommer, är reparation av strömkällan nödvändigt. Kontakt din återförsäljare och upplys om felkoden.

När separata enheter är inkopplade kan följande felkoder visas:

visas, när kommunikationen mellan strömkälla och den/de inkopplade enhet(erna) är försvunna.

visas, när motorstyrningen ej fungerar korrekt.

visas, när motorn är överbelastad.

GRAPHICAL - Speciella funktioner

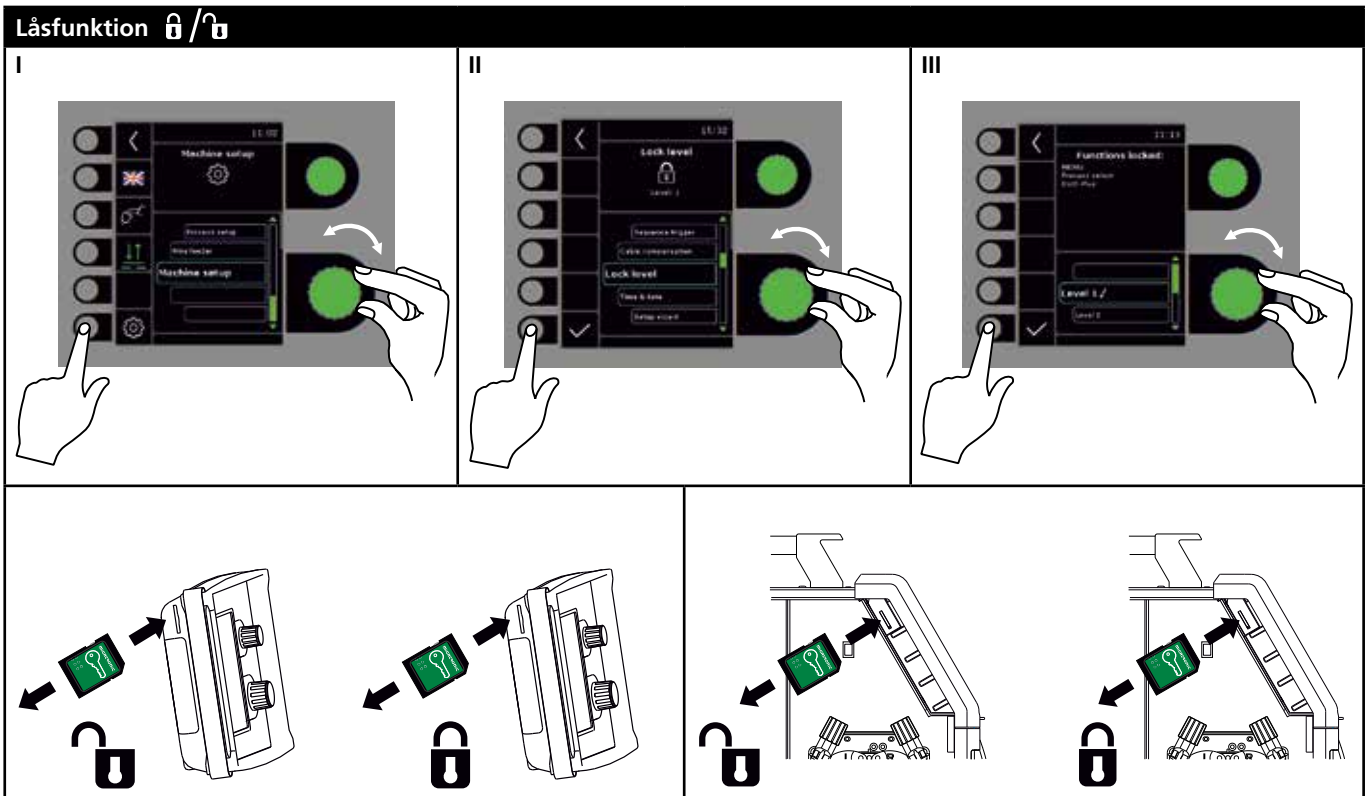

GRAPHICAL - Speciella funktioner

Software / Licenser

I 

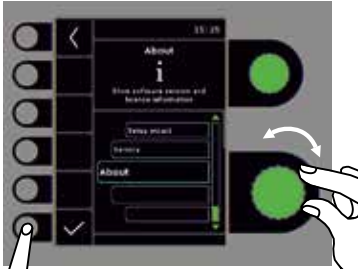
II 

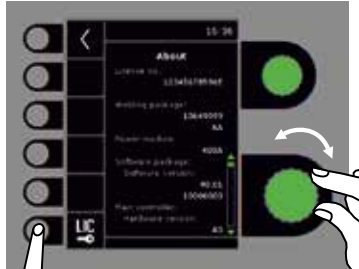
III 

Kabelkompensation (kalibrering av modstånd i slangpaketet)

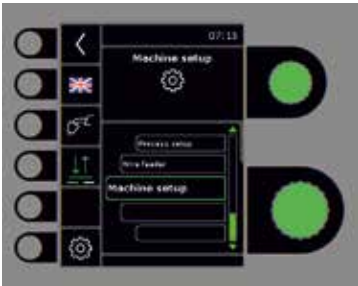
I 

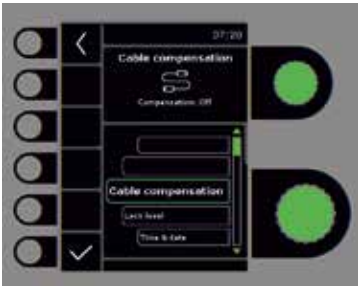
II 

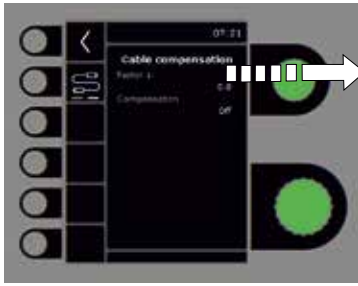
III 

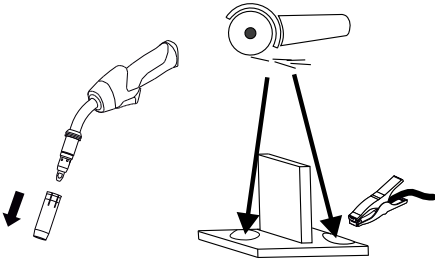
IV 

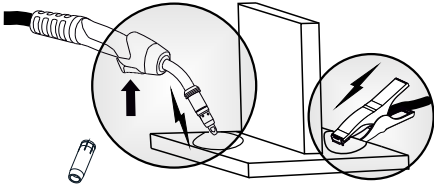
V 

VI 

! Svetsämnets ytskikt skall vara rent för att säkra god kontakt med brännaren.

 = Kabelkompensering aktiverat

Brännar setup

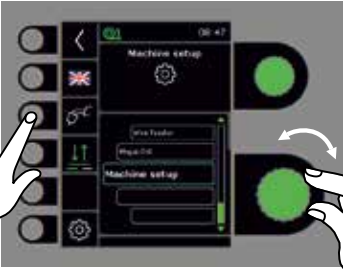
I 

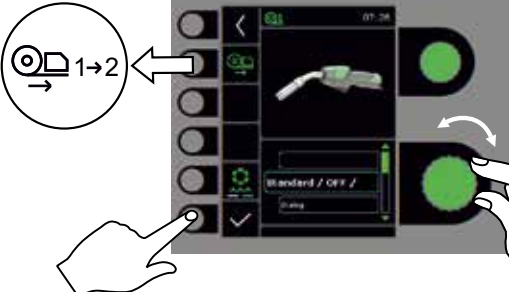
II 

GRAPHICAL - Speciella funktioner

Kalibrering av gasflow (ej alla modeller)

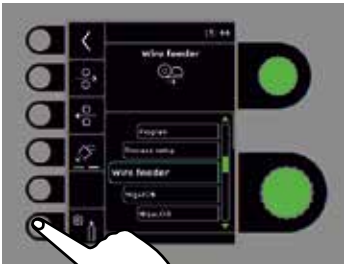
I 

II 

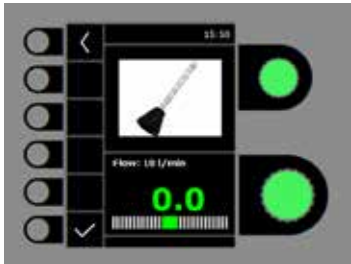
III 

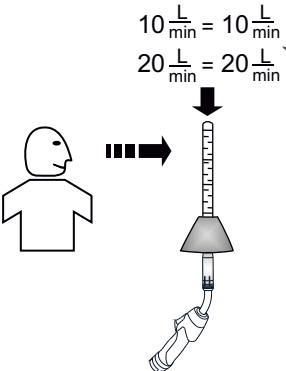
IV 

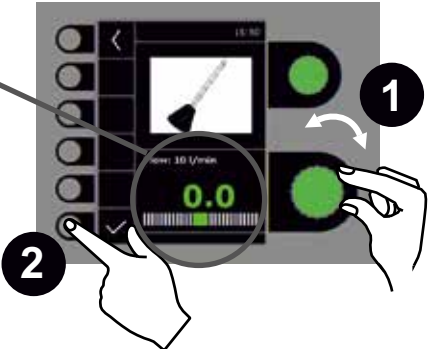
V 

GRAPHICAL - Felhantering

SIGMA Select har ett avancerat skyddssystem inbyggt. Vid fel stänger maskinen automatisk för gastillförseln, avbryter svetsströmmen och stoppar trådmattningen.

Utvalda fel:

Kylfel

Kylfel visas i händelse av att kylvattnet ej kan cirkulera till följd av felaktig anslutning eller tillstoppning.

Kontrollera att kylslangarna är korrekt anslutna, fyll på vattenbehållaren och se över slangpaket och anslutningsrör.

Om kylvätskans viskositet minskar på grund av låga temperaturer, skall Migatronics standard kylvätska bytas ut till 99290515 BTC-20 NF kylvätska, som kännetecknas av sin extremt låga ledningsförmåga och höga viskositet vid temperaturer ned till -17°C.

Skölj igenom systemet innan påfyllning av ny typ av kylvätska.





Kylfelen avanmäls med ett kort tryck på ✓-knappen.

Gasfel (IGC)

Gasfel kan bero på för lågt eller för högt tryck på gastillförseln. Kontrollera att trycket på gastillförseln är högre än 2 bar och mindre än 6 bar, svarande till 5 l/min och 27 l/min.

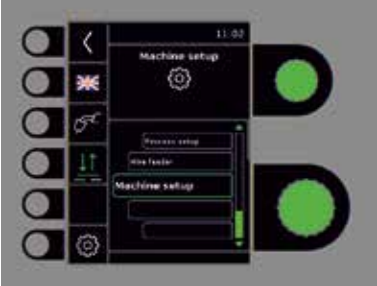
Gasfel kan kopplas ur funktion genom att ställa in manuell gasflow på 27 l/min. Gasfelen avanmäls med ett kort tryck på ✓-knappen.

OBS! Det är viktigt, att det angivna trycket på gastillförseln kan upprätthållas under svetsning.

<p>Fellog</p> <p>I</p>  <p>II</p> 	<p>III</p> 
<p>IV</p> <p>Fellog</p> <p>Alla fel sparas i maskinens fellog under menyn Service.</p> <p>Felloggen kan distribueras, när man sätter in ett SDKort och trycker på följande knapp:</p> <p>Felloggen är nu sparad på SD-kortet.</p> <p>Felloggen kan nollställas, när man trycker på knappen utanför papperskorgen.</p>	

Teknisk data 1

STRÖMKÄLLA SIGMA Select	300		300 IAC		400		400 IAC		550	
Nätspänning $\pm 15\%$ (50-60Hz), V	3x400		3x400		3x400		3x400		3x400	
Minimum generatorstorlek, kVA	16		19		27		29		40	
¹ Minimum kortslutningseffekt S _{sc} , MVA	3,7		4,3		6,0		6,0		9,5	
Säkring, A	16		16		20		20		35	
Nätström effektiv, A	11,0		16,0		17,5		16,5		27,2	
Nätström max., A	15,4		18,3		26,0		28,2		39,2	
Effekt 100%, kVA	9,0		11,1		12,1		11,4		18,9	
Effekt max., kVA	10,7		12,7		18,0		19,5		27,1	
Effekt tomgång, W	11		13		12		13		12	
Verkningsgrad, %	87		85		89		85		90	
Powerfaktor	0,90		0,90		0,90		0,90		0,90	
	MIG	MMA	MIG	MMA	MIG	MMA	MIG	MMA	MIG	MMA
Strömområde, A	15-300	15-250	15-300	15-300	15-400	15-400	15-400	15-400	15-550	15-550
Intermittens 100% 20°C, A	290/28,5	250/30,0	300/29,0	300/32,0	345/31,5	345/33,8	310/29,5	310/32,5	475/37,8	475/39,0
Intermittens max. 20°C, A/%V					400/65/34,0	400/65/36,0	400/60/34,0	400/60/36,0	550/60/41,5	550/60/42,0
Intermittens 100% 40°C, A/V	220/25,0	220/28,8	270/27,5	270/30,8	300/29,0	300/32,0	280/28,0	280/31,2	430/35,5	430/37,2
Intermittens 60% 40°C, A/V	240/26,0	230/29,2			370/32,5	370/34,8	350/31,5	350/34,0	510/39,5	510/40,4
Intermittens max. 40°C, A/%V	300/25/29,0	250/40/30,0	300/80/29,0	300/80/32,0	400/50/34,0	400/45/36,0	400/40/34,0	400/40/36,0	550/50/41,5	550/50/42,0
Tomgångsspänning, V	50-60		65-70		65-70		65-70		75-80	
² Användarklass, C // S	S/CE // S/CE		S/CE // S/CE		S/CE // S/CE		S/CE // S/CE		S/CE // S/CE	
³ Skyddsklass	IP23S		IP23		IP23		IP23		IP23	
Norm, C	IEC60974-1, IEC60974-5, IEC60974-10 Cl. A									
Norm, S	IEC60974-1, IEC60974-10 Cl. A									
Mått C (HxBxL), mm	700x260x735		700x260x735		700x260x735		700x260x735		700x260x735	
Mått S (HxBxL), mm	454x260x735		454x260x735		454x260x735		454x260x735		454x260x735	
Vikt C / S, kg	36,9 / 26		53 / 36		52 / 35		53 / 36		53 / 36	

STRÖMKÄLLA SIGMA Select	300 Boost				300 IAC Boost			
Nätspänning $\pm 10\%$ (50-60Hz), V	3x208-380				3x380-440			
Minimum generatorstorlek, kVA	16				25			
¹ Minimum kortslutningseffekt S _{sc} , MVA	1,7				3,75			
Säkring, A	20				16			
Nätström effektiv, A	19,5				10,6			
Nätström max., A	31,6				16,2			
Effekt 100%, kVA	7,1				7,0			
Effekt max., kVA	11,0				10,6			
Effekt tomgång, W	45				16			
Verkningsgrad, %	82				87			
Powerfaktor	0,95				0,95			
	MIG	MMA	MIG	MMA	MIG	MMA	MIG	MMA
Strömområde, A	15-300	15-250	15-300	15-250	15-300	15-300	15-300	15-300
Intermittens 100% 20°C, A	250/26,5		250/26,5		300/29,0	300/32,0	300/29,0	300/32,0
Intermittens max. 20°C, A/%V	300/40/29,0		300/40/29,0					
Intermittens 100% 40°C, A/V	200/24,0	200/28,0	200/24,0	200/28,0	250/26,5	220/28,8	250/26,5	220/28,8
Intermittens 60% 40°C, A/V	210/24,5	210/28,4	210/24,5	210/28,4	270/27,5	250/30,0	270/27,5	250/30,0
Intermittens max. 40°C, A/%V	300/25/29,0	250/35/30,0	300/25/29,0	250/35/30,0	300/35/29,0	300/30/32,0	300/35/29,0	300/30/32,0
Tomgångsspänning, V	50-60				70-75			
² Användarklass, C // S	S/CE // S/CE				S/CE // S/CE			
³ Skyddsklass	IP23S				IP23			
Norm, C	IEC60974-1, IEC60974-5, IEC60974-10 Cl. A				IEC60974-1, IEC60974-5, IEC60974-10 Cl. A			
Norm, S	IEC60974-1, IEC60974-10 Cl. A				IEC60974-1, IEC60974-10 Cl. A			
Mått C (HxBxL), mm	700x260x735				900x260x735			
Mått S (HxBxL), mm	454x260x735				654x260x735			
Vikt C / S, kg	45 / 34				66 / 49			

1) Denna utrustning är i överensstämmelse med EN / IEC61000-3-12:2014 (/ 2011), förudsatt att nätets kortslutningseffekt S_{sc} vid anslutningsstället är större än eller lika med uppgivna data i ovanstående schema. Installatören eller användaren av utrustningen är ansvarig för att säkra, evt. i samråd med försörjningsdistributören, att utrustningen är anslutet till en nätförsörjning med en kortslutningseffekt S_{sc} större än eller lika med de uppgivna data i ovanstående schema.

2) S Maskiner uppfyller de krav som ställs för användning i områden med ökad risk för elektrisk chock

3) Maskinen är godkänd till inomhus och utomhus användning enligt skyddsklass IP23 / IP23S.

IP23S: Maskinen kan förvaras men är inte beräknad för att användas utomhus vid nederbörd, om den inte är avskärmd

Teknisk data 2

STRÖMKÄLLA SIGMA Select	400 Boost				400 IAC Boost			
Nätspänning $\pm 10\%$ (50-60Hz), V	3x208-380		3x380-440		3x208-380		3x380-440	
Minimum generatorstorlek, kVA	25		25		25		25	
¹⁾ Minimum kortslutningseffekt S _{sc} , MVA					4,0		4,0	
Säkring, A	25-50		25-50		25-50		25-50	
Nätström effektiv, A	22,0		11,7		24,8		11,8	
Nätström max., A	45,0		23,5		48,0		24,5	
Effekt 100%, kVA	8,3		8,1		8,5		8,5	
Effekt max., kVA	16,7		16,3		17,4		17,4	
Effekt tomgång, W	60		56		60		71	
Verkningsgrad, %	84		88		82		85	
Powerfaktor	0,96		0,95		0,96		0,96	
	MIG	MMA	MIG	MMA	MIG	MMA	MIG	MMA
Strömområde, A	15-400	15-400	15-400	15-400	15-400	15-400	15-400	15-400
Intermittens 100% 20°C, A	300/29,0	300/32,0	300/29,0	300/32,0	300/29,0	300/32,0	300/29,0	300/32,0
Intermittens max. 20°C, A/V	400/30/34,0	400/30/32,0	400/30/34,0	400/30/32,0	400/30/34,0	400/30/32,0	400/30/34,0	400/30/32,0
Intermittens 100% 40°C, A/V	250/26,5	220/28,8	250/26,5	220/28,8	250/26,5	220/28,8	250/26,5	220/28,8
Intermittens 60% 40°C, A/V	280/28,0	260/30,4	280/28,0	260/30,4	280/28,0	260/30,4	280/28,0	260/30,4
Intermittens max. 40°C, A/V	400/25/34,0	400/20/36,0	400/25/34,0	400/20/36,0	400/25/34,0	400/20/36,0	400/25/34,0	400/20/36,0
Tomgångsspänning, V	70-75				70-75			
²⁾ Användarklass, C // S	S/CE // S/CE				S/CE // S/CE			
³⁾ Skyddsklass	IP23				IP23			
Norm, C	IEC60974-1, IEC60974-5, IEC60974-10 Cl. A				IEC60974-1, IEC60974-5, IEC60974-10 Cl. A			
Norm, S	IEC60974-1, IEC60974-10 Cl. A				IEC60974-1, IEC60974-10 Cl. A			
Mått C (HxBxL), mm	900x260x735				900x260x735			
Mått S (HxBxL), mm	654x260x735				654x260x735			
Vikt C / S, kg	66 / 49				67 / 50			

MATERVERK MWF			
Trädmatningshastighet, m/min	0,5-30,0		
Brännanslutning	EURO		
Trädspolediameter, mm	300		
Trädrulle, kg	5-18		
Intermittens 100 % 40°C, A/%	430		
Intermittens 60% 40°C, A/%	500		
Intermittens max. 40°C A/%	550/50		
³⁾ Skyddsklass	IP23		
Träddiameter, mm	0,6-1,6		
Gasträck, MPa (bar)	0,6 (6,0)		
	MWF 30	MWF 32	MWF 33
Mått (HxBxL), mm	413x310x750	457x260x672,5	457x260x672,5
Vikt, kg	11,6	14,0	14,0
Norm	IEC60974-5, IEC60974-10 CL. A		

KYLMODUL MCU 1300	
Kyleffekt (1 l/min), W	1300
Kyleffekt (1,5 l/min), W	1600
Tanncapacitet, liter	5
Flow, bar - °C - l/min	3,0-60-1,5
Tryck max., bar	5
Norm	IEC60974-2, IEC60974-10 CL.A
Mått (HxBxL), mm	207x260x680
Vikt	20

EU FÖRSÄKRAN OM ÖVERENSSTÄMMELSE

CE

MIGATRONIC A/S
Aggersundvej 33
9690 Fjerritslev
Danmark

Härmed försäkras vi att våra maskiner enligt nedan
Typ: SIGMA Select
överensstämmer med riktlinjerna
i direktiven: 2014/35/EU
2014/30/EU
2011/65/EU

Europeiska
standarder: EN IEC60974-1:2018/A1:2019
EN IEC60974-2:2019
EN IEC60974-5:2019
EN / IEC60974-10:2014/A1:2015

Förordning: 2019/1784/EU

Utfärdad i Fjerritslev 10.02.2021

Kristian M. Madsen
Kristian M. Madsen
CEO

- Denna utrustning är i överensstämmelse med EN / IEC61000-3-12:2014 (/ 2011), förudsatt att nätets kortslutningseffekt S_{sc} vid anslutningsstället är större än eller lika med uppgivna data i ovanstående schema. Installatören eller användaren av utrustningen är ansvarig för att säkra, evt. i samråd med försörjningsdistributören, att utrustningen är anslutet till en nätförsörjning med en kortslutningseffekt S_{sc} större än eller lika med de uppgivna data i ovanstående schema.
- S** Maskiner uppfyller de krav som ställs för användning i områden med ökad risk för elektrisk chock
- Maskinen är godkänd till inomhus och utomhus användning enligt skyddsklass IP23 / IP23S.
IP23S: Maskinen kan förvaras men är inte beräknad för att användas utomhus vid nederbörd, om den inte är avskärmd

Collegamenti ed uso

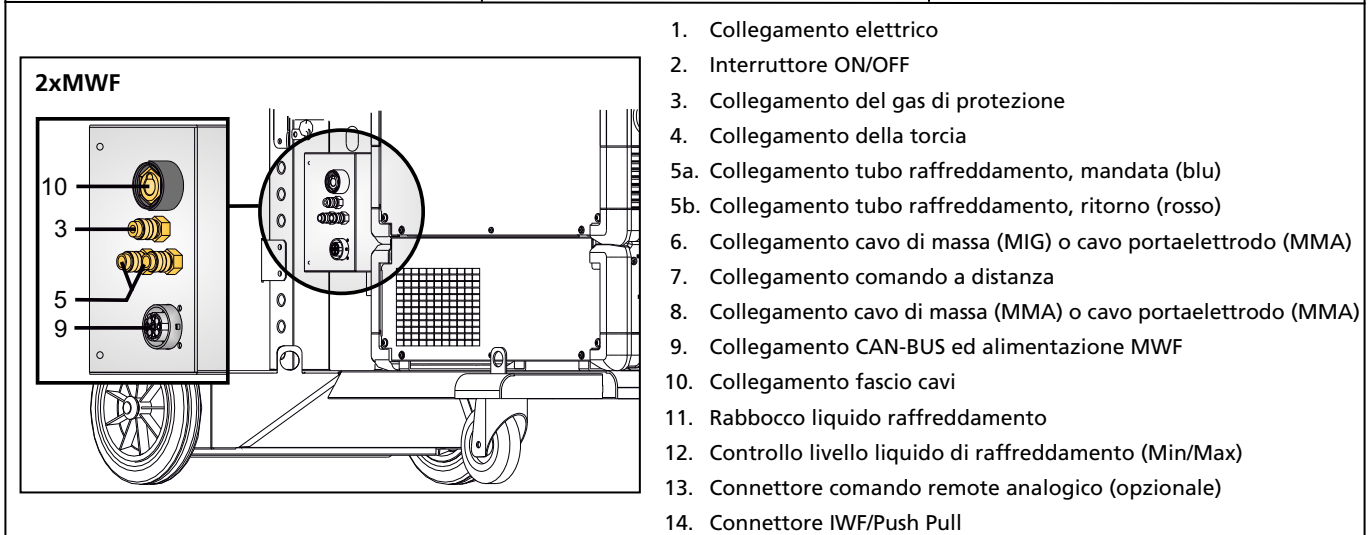
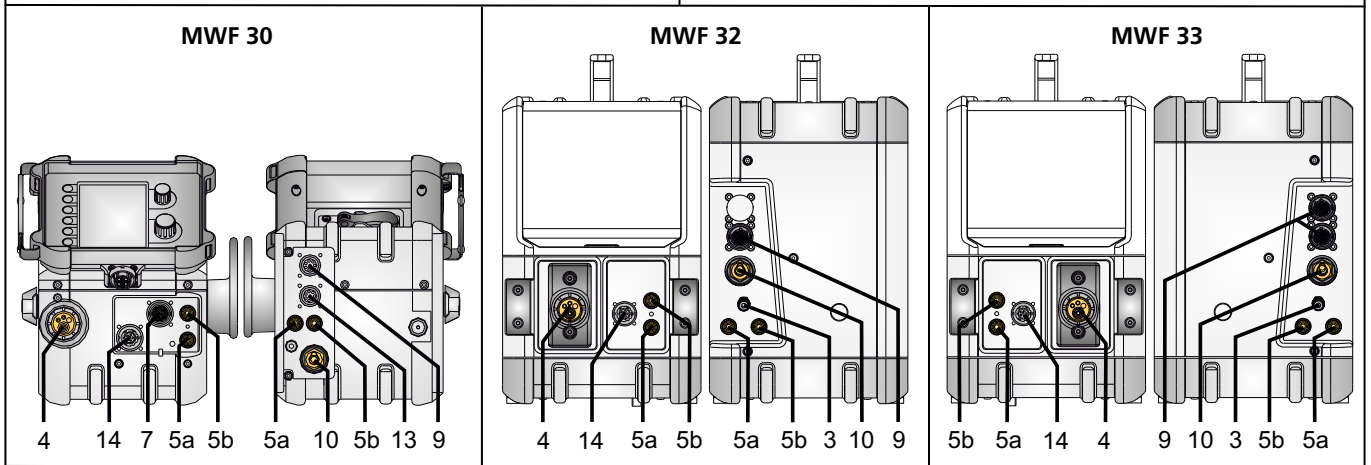
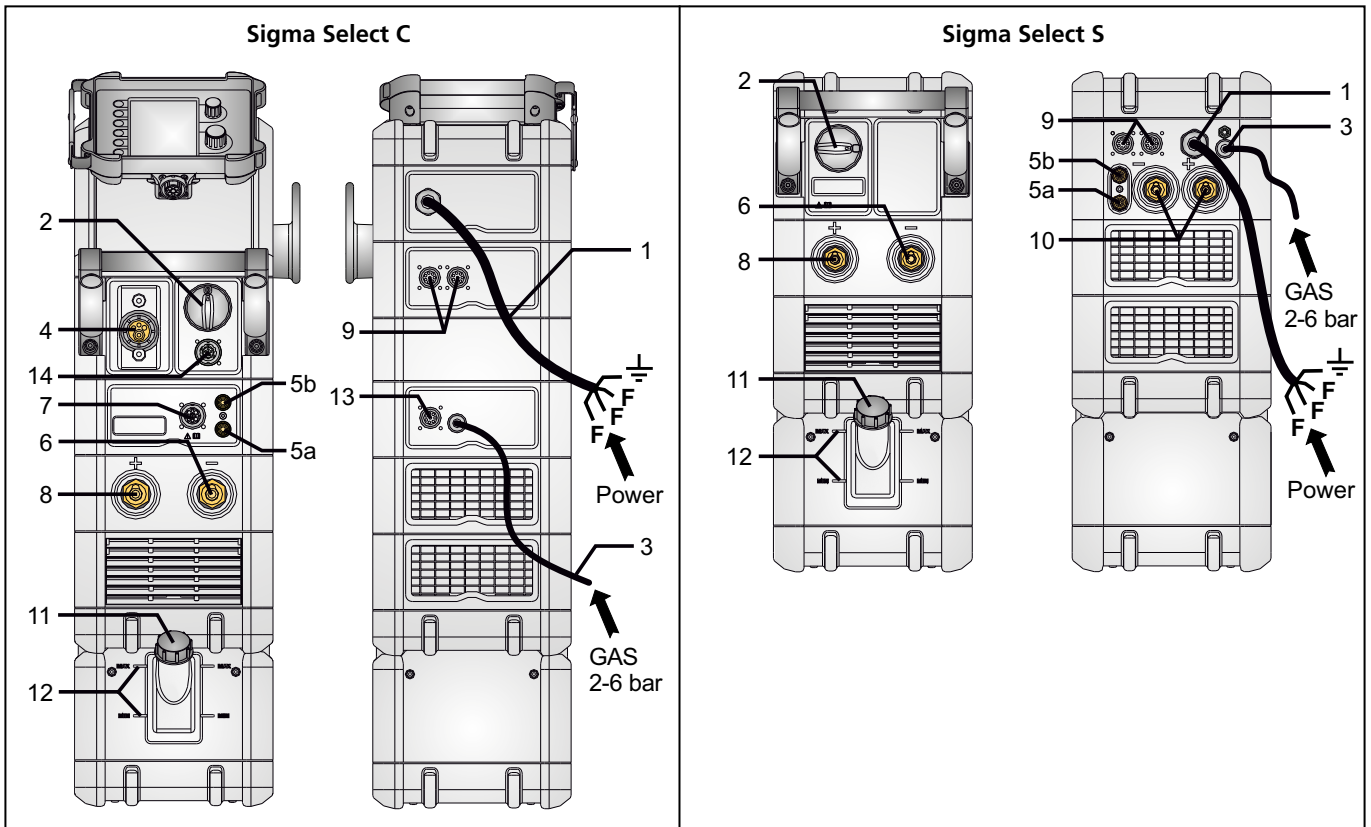

Collegamenti ed uso



Attenzione

Leggere attentamente le avvertenze e il manuale prima della messa in funzione e salvare le informazioni per un uso futuro.

Installazione

Collegamento elettrico

Collegare la macchina alla corretta alimentazione elettrica. Verificare il valore (U_i) sulla targa dati situata sul retro della macchina.

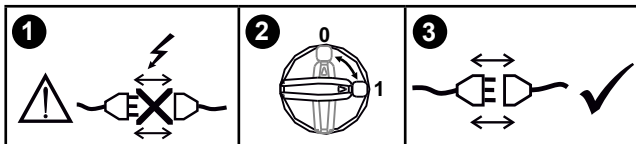
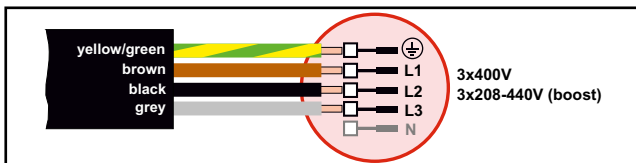

Kit stabilizzatore di tensione

Il generatore di potenza è possibile configurarla con un kit di stabilizzazione della tensione come protezione contro variazioni di tensione maggiori, ad es. Nel caso di utilizzo della saldatrice con un gruppo di alimentazione separato, tipo generatore.

Collegamento all'alimentazione gas

Collegare il tubo del gas, posizionato sul pannello posteriore della saldatrice (3), ad una alimentazione di gas con regolatore di pressione (2-6 bar). (Nota: alcuni tipi di regolatori richiedono una pressione di uscita superiore a 2 bar per funzionare in modo ottimale). Una/due bombole di gas possono essere montato sul carrello portabombole.

Consumo di gas

A seconda dell'attività di saldatura, del tipo di gas e del design del cordone, il consumo di gas varierà in intervalli da 6-7 l/min a bassi amperaggi (<25 A) e fino a 27 l/min a max. amperaggio.

Consumo di materiale

Il consumo di materiale può essere stimato calcolando il tempo di saldatura in minuti moltiplicato per la velocità di avanzamento del filo (m/min) moltiplicato per il peso al metro dei consumabili di saldatura in uso.

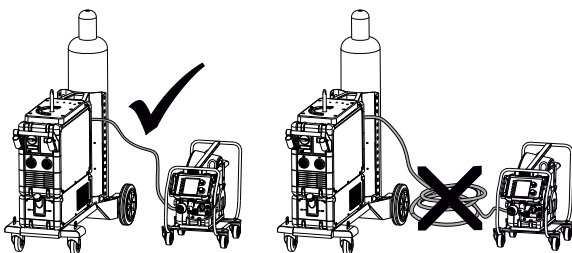

ATTENZIONE

Quando si schiaccia il pulsante torcia c'è presenza di tensione elettrica sul filo di saldatura/sull'elettrodo.

Collegamento della torcia

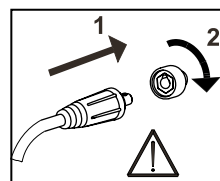
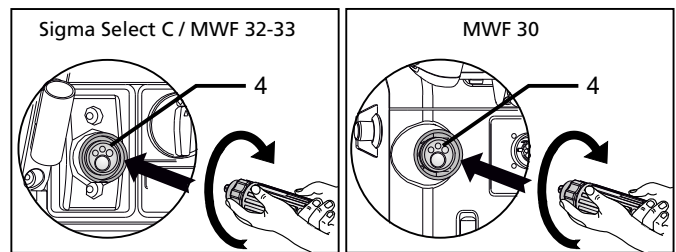

Importante!

Per evitare danni alle prese e ai cavi è importante verificare che ci sia un buon contatto elettrico quando si collegano i cavi di saldatura.

Collegamento della pinza portaelettrodo per MMA

Il cavo portaelettrodo e quello di massa vanno collegati al polo positivo (10) e negativo (8). Osservare le istruzioni del fornitore dell'elettrodo nello scegliere la polarità.

Sezione dei cavi consigliata

AMPERE	DC	PULSATO
200 A	35 mm ²	35 mm ²
300 A	50 mm ²	70 mm ²
400 A	95 mm ² / 2x50 mm ²	95 mm ² / 2x50 mm ²
550 A	2x70 mm ²	2x70 mm ²

Processo di saldatura	Distanza dal pezzo (a+b)	Lunghezza massima dei cavi di saldatura (a+b+c)
MIG - IAC e pulsato	10 m	20 m
MIG - non pulsato	30 m	60 m

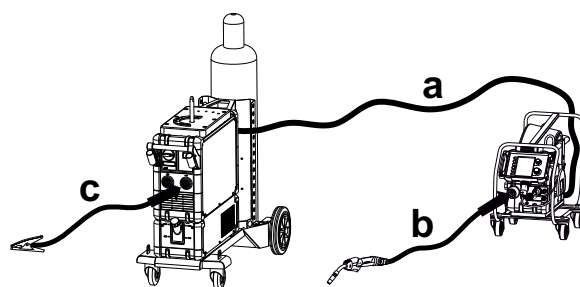

Regolazione del freno del filo

Il freno nell'aspo portabobina assicura che la bobina non continui a srotolarsi alla fine della saldatura. La forza del freno dipende dal peso della bobina di filo e dalla velocità del trainafilo. Il valore di fabbrica è 15kg

Regolazione freno:

- Smontate la manopola di blocco infilando un cacciavite sottile dietro la manopola e tiratela fuori.
- Regolate il freno del filo stringendo o allentando il dado sull'albero dell'aspo.
- Reinsere la manopola di blocco.

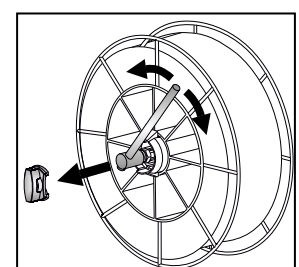

Collegamenti ed uso

Istruzioni di sollevamento

I punti di sollevamento devono essere utilizzati (vedere la figura) quando si solleva la macchina o l'unità MWF. La macchina non deve essere sollevata con la bombola del gas montata.

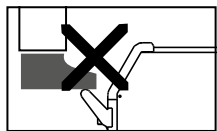
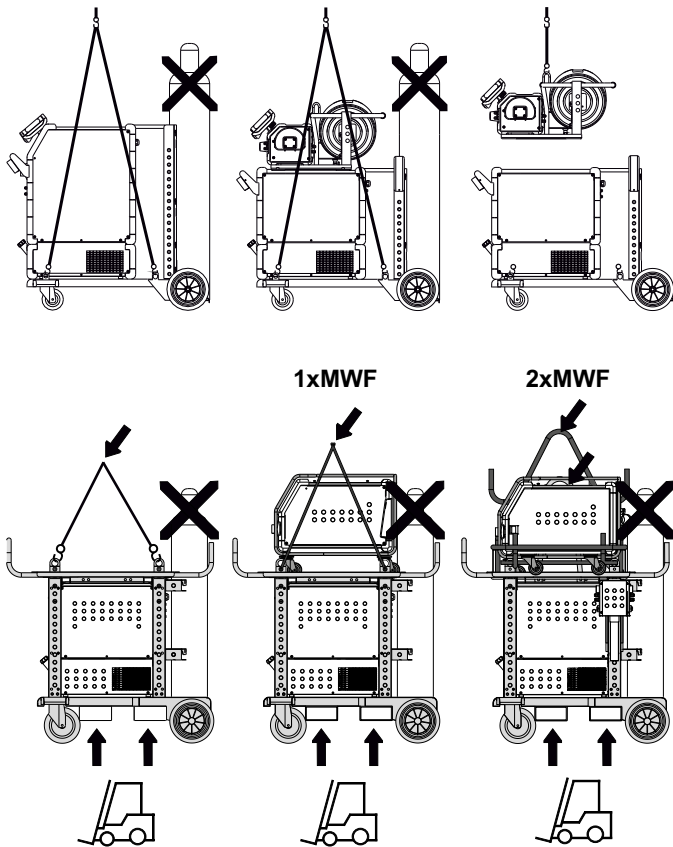

Non sollevare la macchina per la maniglia.
Non calpestare la maniglia.

Fissaggio del Pannello di controllo

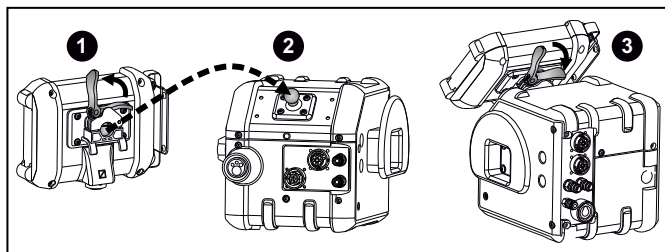

MWF 30 supporto avvolgimento del filo

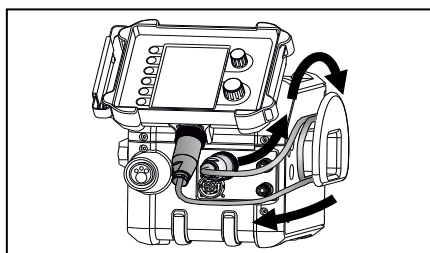

Ventilazione MCU

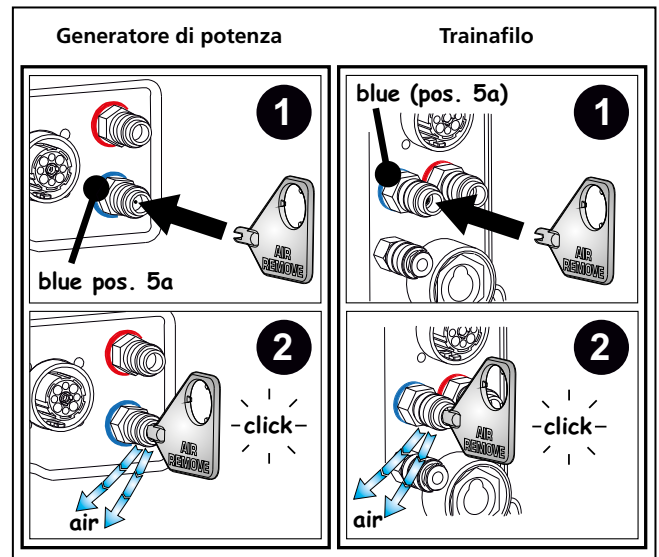

Funzione di blocco MWF

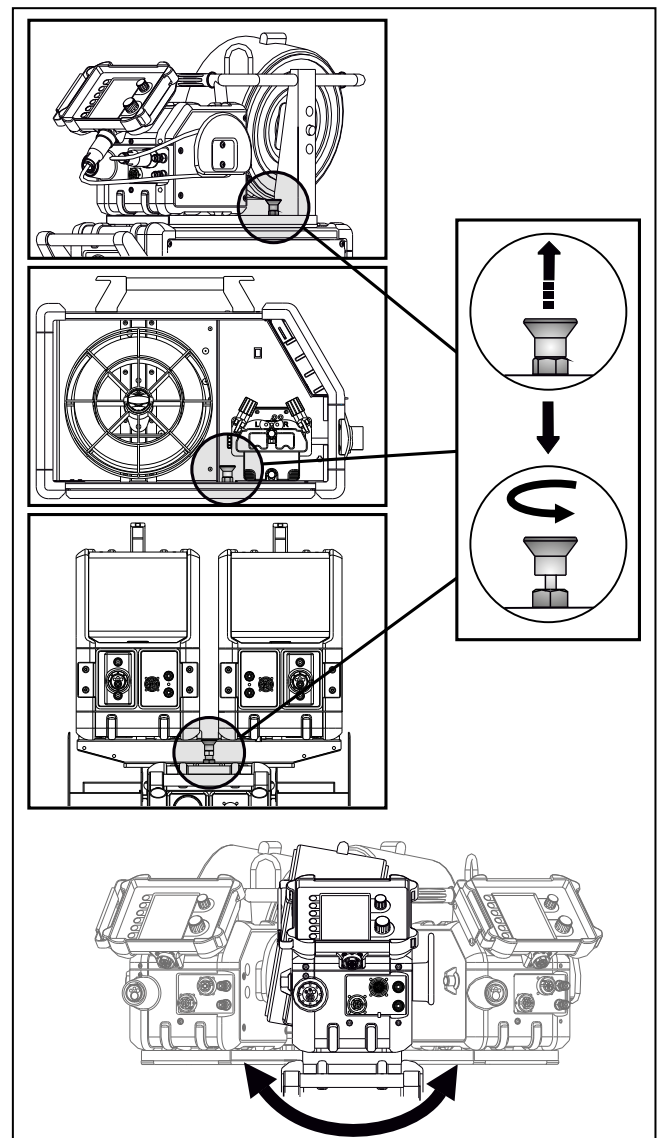

Collegamenti ed uso

Assemblaggio parti traina filo

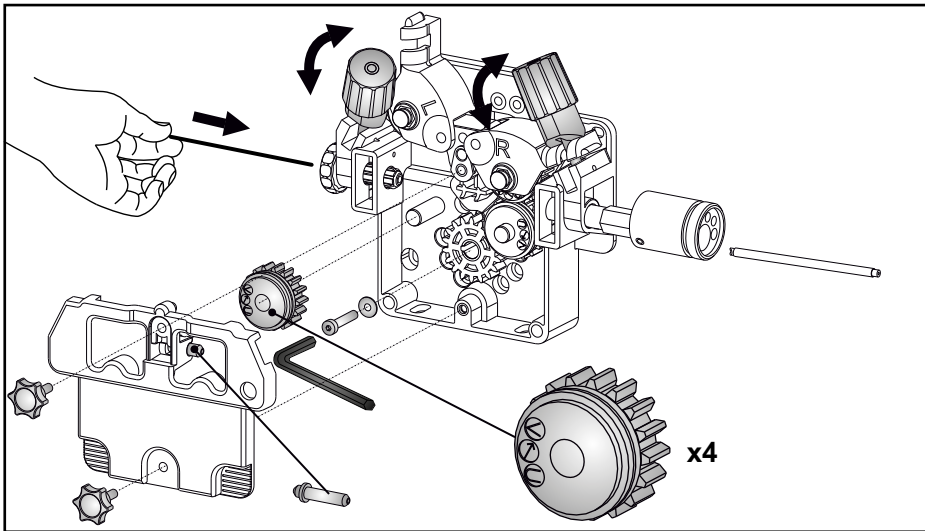

La pressione della vite di regolazione deve essere tale che i rulli slittino sul filo quando questo viene bloccato.

Filo Avanti/indietro

L'avanzamento del filo può essere attivato premendo i pulsanti o dalla interfaccia robot, se il trainafilo MWF30 è usato in configurazione robot.

Avanzamento del filo

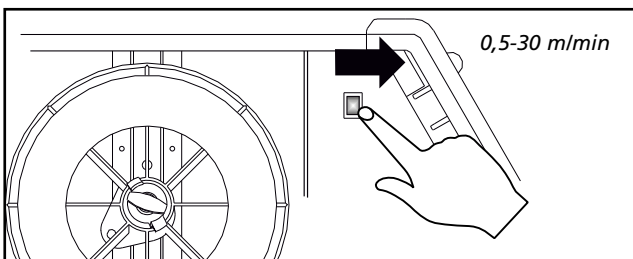

Avanzamento del filo MWF 30

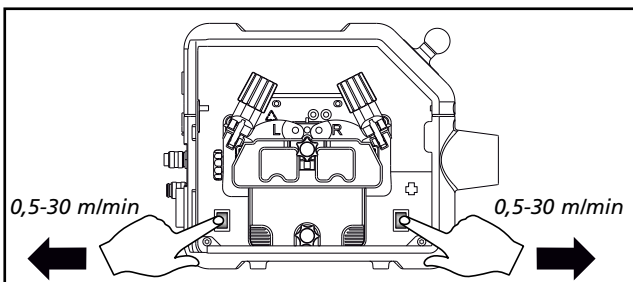

Avanzamento del filo Graphical

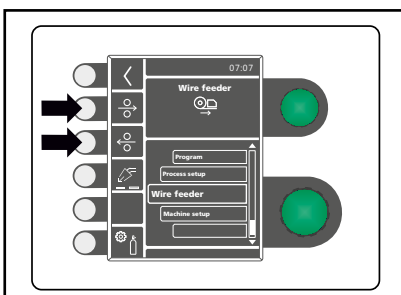

Aggiornamento Software

- Caricamento software.
- Accendere la macchina.
- Attendere che l'unità indichi che l'aggiornamento è completato.
- Spegnere la macchina e rimuovere la carta SD.
- La macchina è ora pronta all'uso.

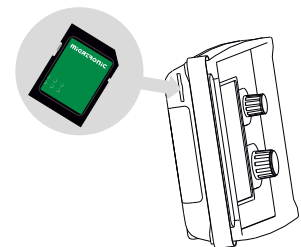

Il nuovo software verrà caricato nella saldatrice ed in tutte le unità collegate.

Il software si può scaricare da : <http://migatron.com> su una scheda SD. La scheda SD deve essere formattata FAT32.

IMPORTANTE:

Salvare il software nella directory //MIGA_SW/SIGMA/

Licenza SW

Se si acquistano licenze aggiuntive per programmi o funzioni speciali, caricare i file MigaLic.dat come i pacchetti software. Ricordarsi di effettuare un backup.

Il file MigaLic.txt contiene informazioni sul numero di licenza e sulle licenze salvate sulla scheda SD.

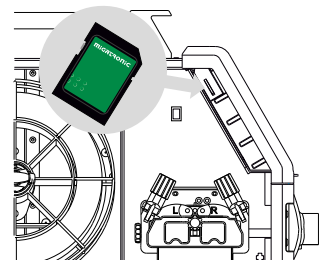

BASIC - Funzioni speciali

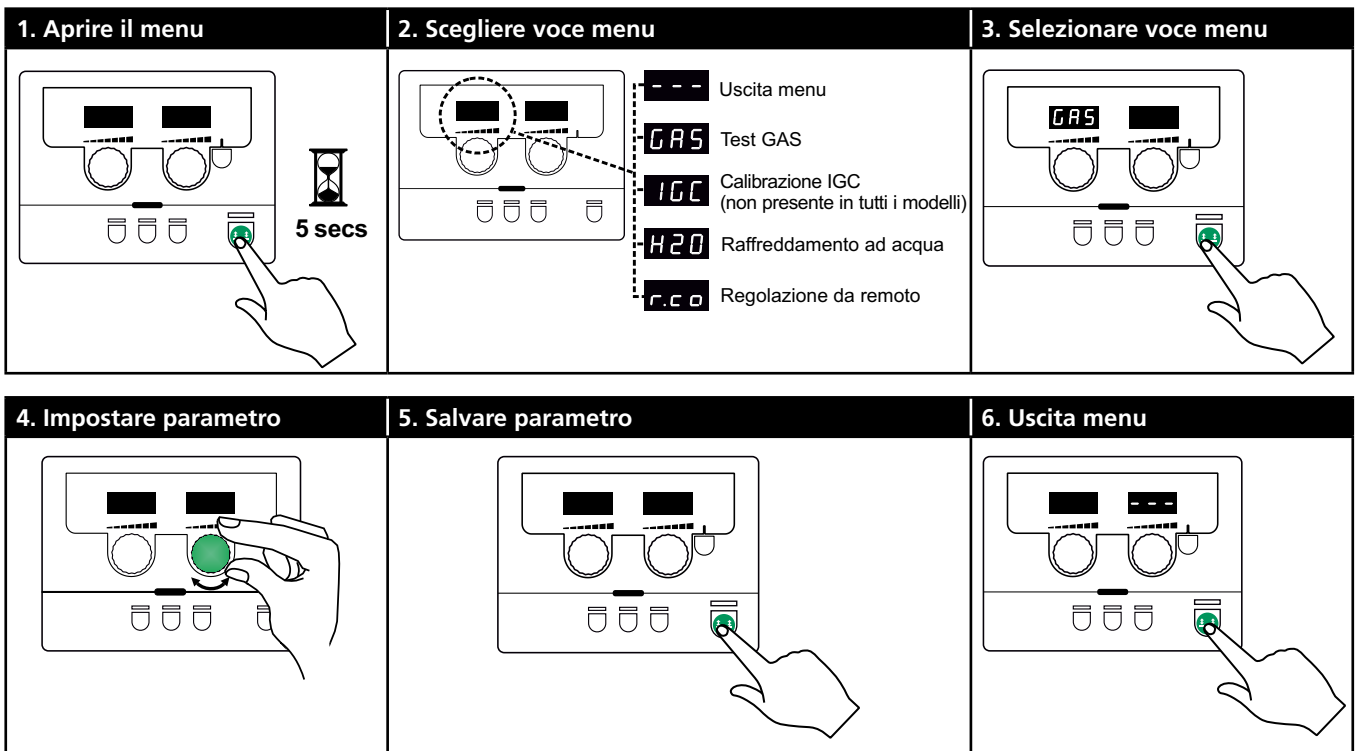

Menu selezione parametri

Premere e tenere premuto il tasto per aprire il menu utente. Ruotare la manopola di sinistra fino a visualizzare il menu desiderato. Utilizzare la manopola di destra per modificare le impostazioni visualizzate sul display destro. Premere brevemente il tasto per attivare le funzioni, come la prova di gas.

--- **GAS** **IGC** **H2O** **r.c.o**

Funzioni e parametri del menu utilizzatore:

--- Premere il tasto per uscire dal menu.

GAS Test GAS
 Preme il tasto per attivare o disattivare l'elettrovalvola del gas. Se il kit IGC è installato è possibile aggiustare il flusso di gas con la manopola di destra.

IGC Calibrazione IGC
 Visibile solo se installato il Kit IGC.
 Premere il tasto per iniziare la calibrazione dell' IGC.

H2O Raffreddamento ad acqua
 Visibile solo se installato il unità di raffreddamento.
 0: Raffreddamento ad acqua OFF
 1: Raffreddamento ad acqua ON

r.c.o Settaggio regolazione da remoto
 Usare il potenziometro di destra per selezione le seguenti opzioni:
 0: Disabilitata
 1: Regolazione da torcia (codice 80100402)
 2: Comando a distanza analogico (codice 78815029)

BASIC - Funzioni speciali

Configurazioni di controllo esterno

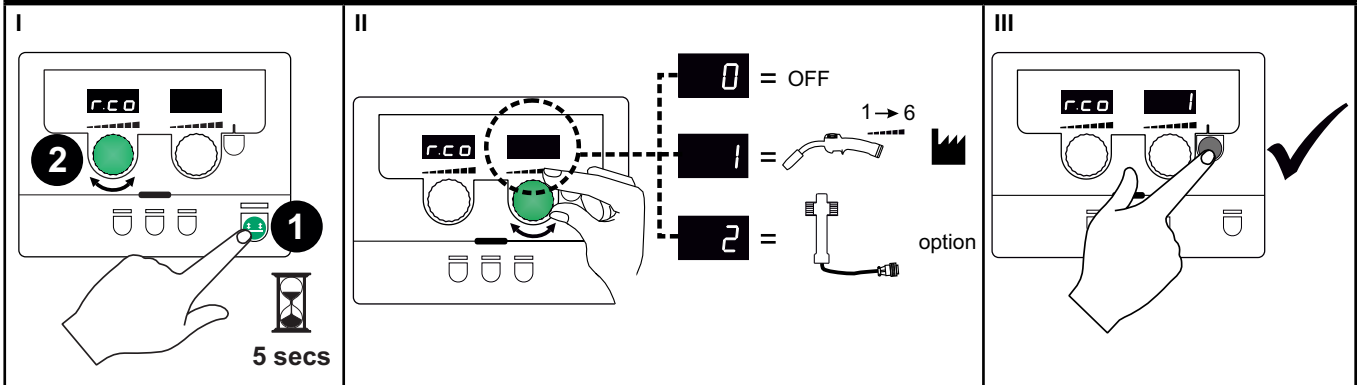

Funzione Blocco /

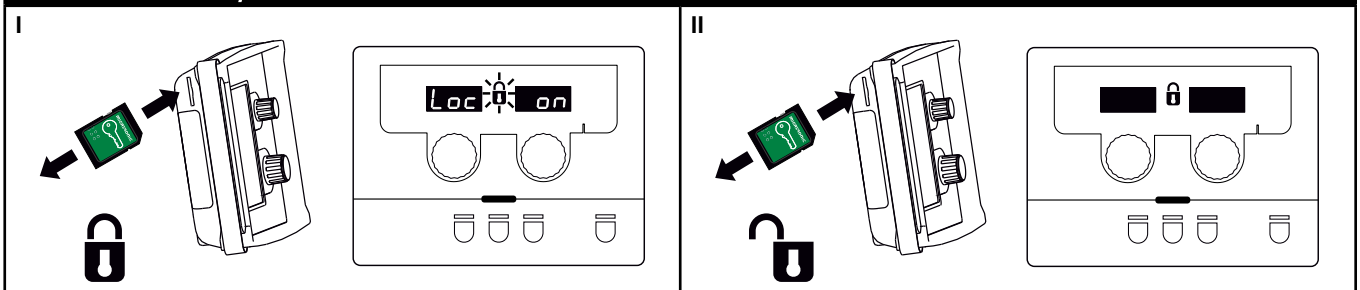

Calibrazione del flusso di gas (non presente in tutti i modelli)

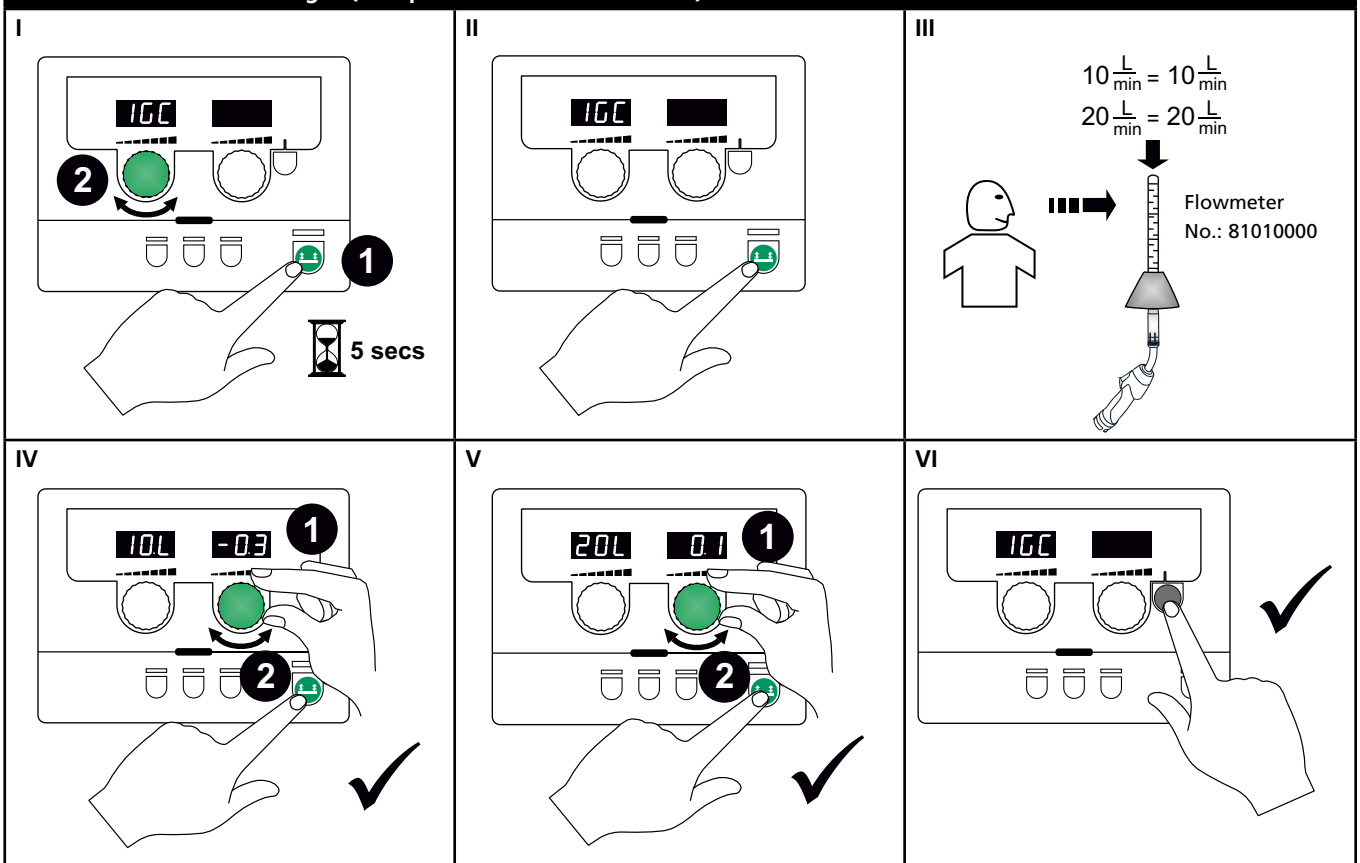

BASIC - Funzioni speciali

Visualizzazione versione software/numero licenza

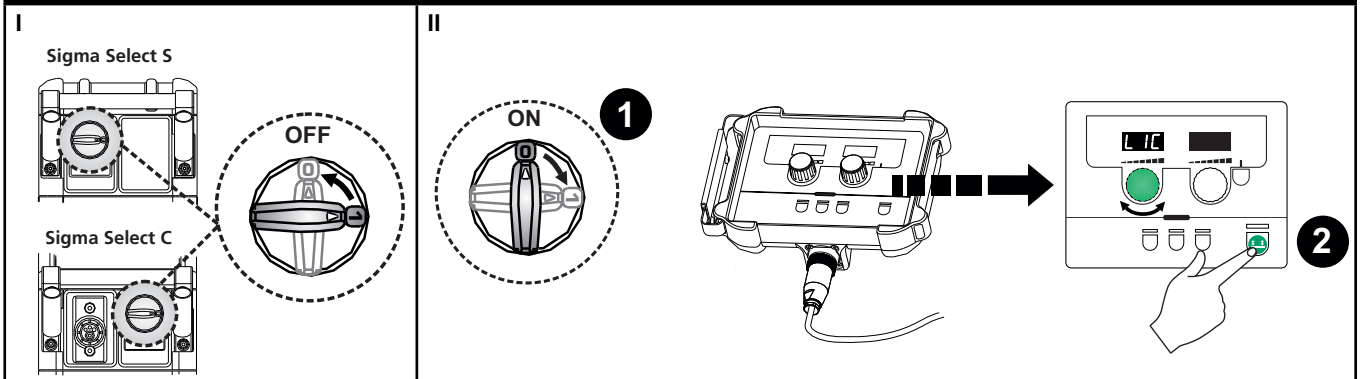

1. Numero licenza

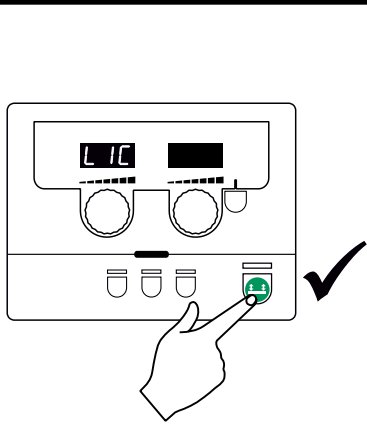

2. Vedere licenza no. (12 cifre)

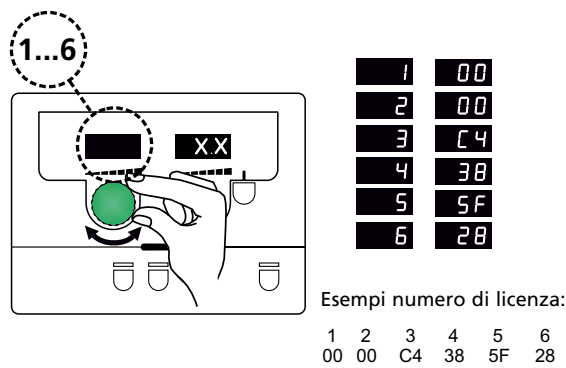

3. Ritorno alla versione SW

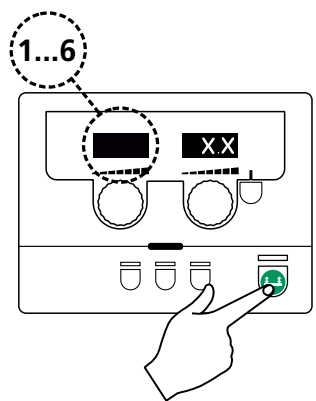

4. Selezionare SW

- Basic remote **1**
- Welding package **2**
- Main controller **3**
- "-" **4**
- "-" **5**
- Wire feeder **6**
- Wire feeder **7**
- Arc controller **8**
- "-" **9**
- "-" **10**
- "-" **11**
- "-" **12**
- "-" **13**
- "-" **14**
- "-" **15**
- "-" **16**
- Water controller **17**
- Smart Torch **18**

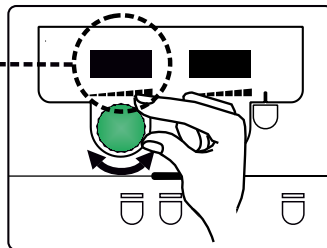

5. Uscita menu

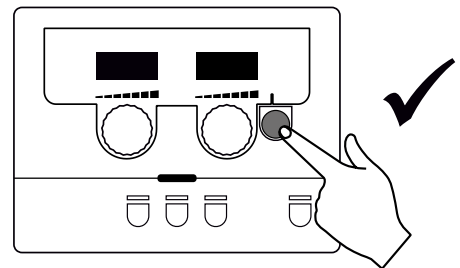



"-" not supported

BASIC - Gestione errori

Codice d'errore	Causa e soluzione
E20-00 E20-02 E21-00 E21-06 E21-08	Non c'è presenza di software nell'unità di controllo Scaricare il software sulla carta SD, inserire la Carta SD con software e accendere la macchina. Sostituire la carta SD se necessario.
E20-01 E21-01	La carta SD non è formattata La carta SD deve essere formattata in un PC come FAT prima di scaricare il software. Sostituire la carta SD se necessario.
E20-03 E21-02	La carta SD contiene più files con lo stesso nome Cancellare i files sulla carta SD e ricaricare il software.
E20-04	L'unità di controllo cerca di leggere più dati di quanti accessibili nella memoria Inserire nuovamente la carta SD o sostituire la carta SD. Contattare il Servizio Assistenza Migatronic se il problema non viene risolto.
E20-05 E20-06	Il software sulla carta SD è relativo ad un altro tipo di unità di controllo Usare una carta SD con il software corretto per l'unità di controllo disponibile.
E20-07	La protezione copia interna non permette l'accesso al microprocessore Inserire nuovamente la carta SD nella macchina o contattare il Servizio Assistenza Migatronic.
E20-08 E20-09 E21-05	L'unità di controllo è difettosa Contattare il Servizio Assistenza Migatronic.
E20-10 E21-07	Il file caricato ha un errore Inserire nuovamente la carta SD nella macchina o cambiare la carta SD.
E21-03 E21-04	Il pacchetto programmi non è relativo all'unità di controllo Usare una carta SD con software corretto per l'unità di controllo in uso.
Err GAS	Errore gas Controllare l'alimentazione gas. Per eliminare l'allarme, schiacciare un tasto qualunque.
E02-04	Errore di comunicazione CAN Controllare il fascio cavi e le connessioni
E11-20	Errore sensore di corrente 1. Controllare il sensore di corrente. 2. Contattare il Servizio Assistenza Migatronic.

Simboli di allarme

 **Allarme surriscaldamento**
Il LED si illumina in caso di surriscaldamento della macchina.
Lasciate la macchina in funzione finché il ventilatore non abbia abbassato la temperatura.

 **Allarme di corrente**
Il LED lampeggia quando la corrente è superiore ai valori ammessi dalla macchina. Assicuratevi che la velocità filo/corrente e la tensione siano regolate correttamente.

 **Simboli di allarme**
Il LED lampeggia quando si verificano altri tipi di errore. Allo stesso tempo il codice dell'errore relativo è mostrato sul display.

Esempi di codici di errore



 **E11 15 Allarme alimentazione elettrica**
Il simbolo indica che la tensione di alimentazione è troppo alta. Collegare la saldatrice 400V AC, +/-15% 50-60Hz.

 **Err H2O Allarme raffreddamento torcia**
Questo errore viene indicato solo nelle macchine dotate di flussostato in caso di mancata circolazione acqua. Controllate che i tubi siano correttamente collegati, riempire il serbatoio dell'acqua e controllare la torcia.

Se la viscosità del liquido di raffreddamento si riduce a causa delle basse temperature, il liquido di raffreddamento standard Migatronic deve essere sostituito con il liquido di raffreddamento 99290515 BTC-20 NF, che si caratterizza per la sua conducibilità estremamente bassa e l'elevata viscosità fino a temperature di -17°C.

Lavare il sistema prima di aggiungere un nuovo tipo di refrigerante.

L'allarme raffreddamento si cancella schiacciando brevemente il tasto .

 **Err GAS Errore gas (IGC)**
L'errore è dovuto a pressione del gas troppo bassa o troppo alta. Assicurarsi che la pressione d'uscita del gas sia compresa tra 2 e 6 bar, corrispondenti a 5 e 27 l/min. L'allarme viene disinserito regolando la portata a 27 l/min. L'allarme viene spento premendo brevemente il tasto .

Allarme alimentazione filo

 **E01 00** o  **E01 01**

Il simbolo indica che il motore trainafilo è sovraccaricato.

Il motore traino potrebbe essere difettoso.

Altri tipi di allarme

Se altri simboli di allarme vengono visualizzati, spegnere e riaccendere la macchina. Se il simbolo continua ad essere visualizzato, è necessario un intervento tecnico. Contattare il distributore Migatronic indicando il simbolo visualizzato.

Quando sono collegate unità separate, i seguenti codici di errore possono essere visualizzati:

 **E07 04** viene visualizzato quando la comunicazione tra il generatore e l'unità collegata (s) è persa.

 **E07 05** indica problemi sul controllo motore.

 **E07 06** indica che il motore è sovraccaricato.

GRAPHICAL - Funzioni speciali

Configurazione guidata

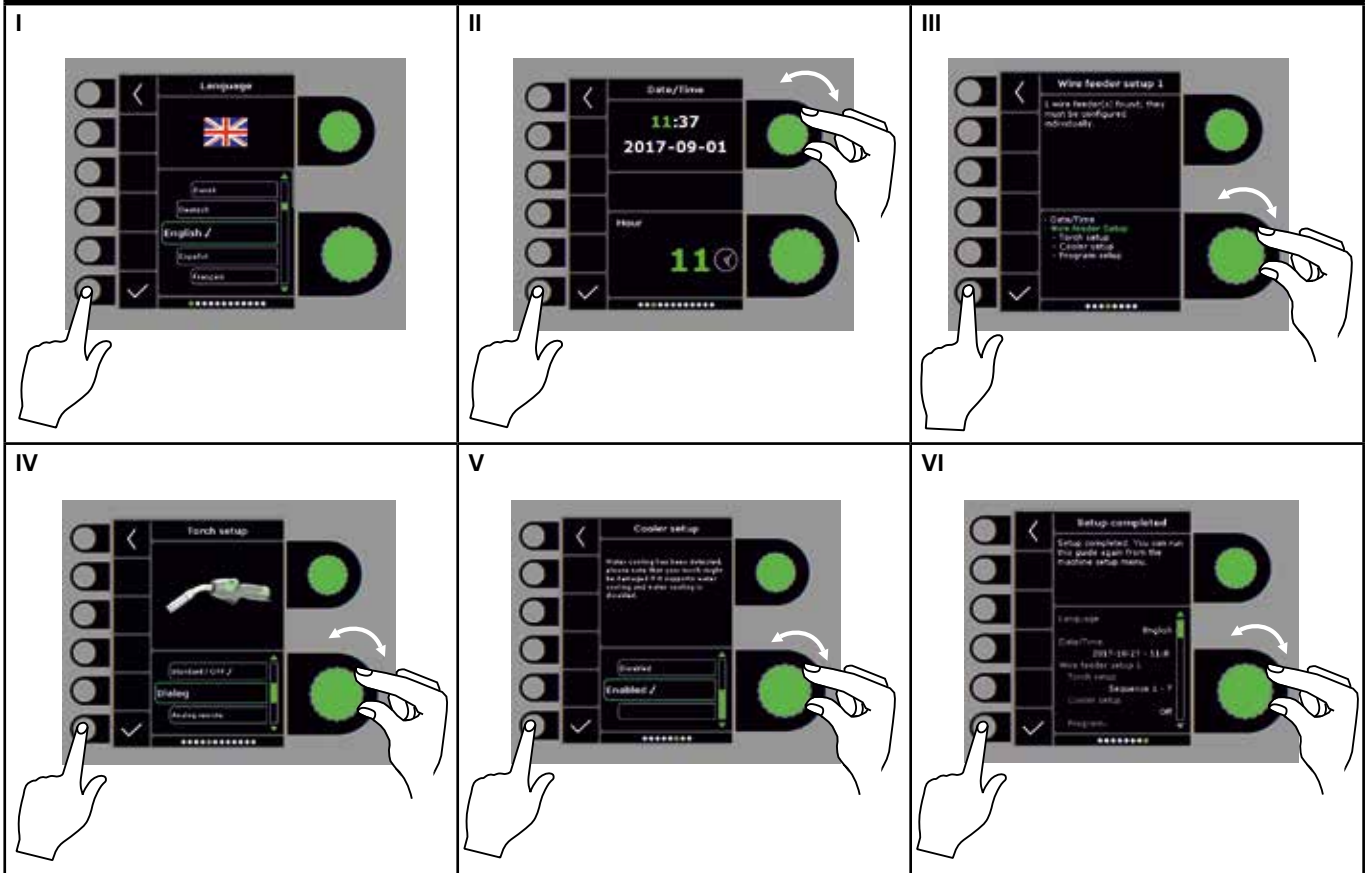

Funzione Blocco

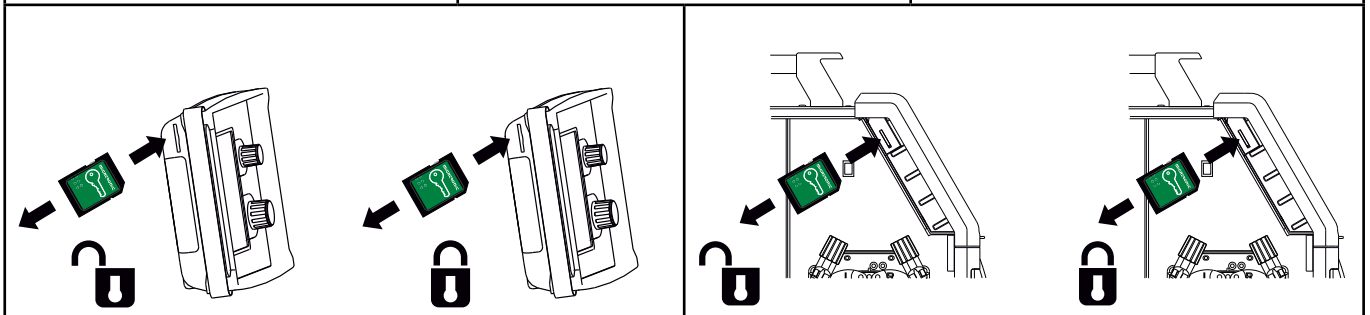
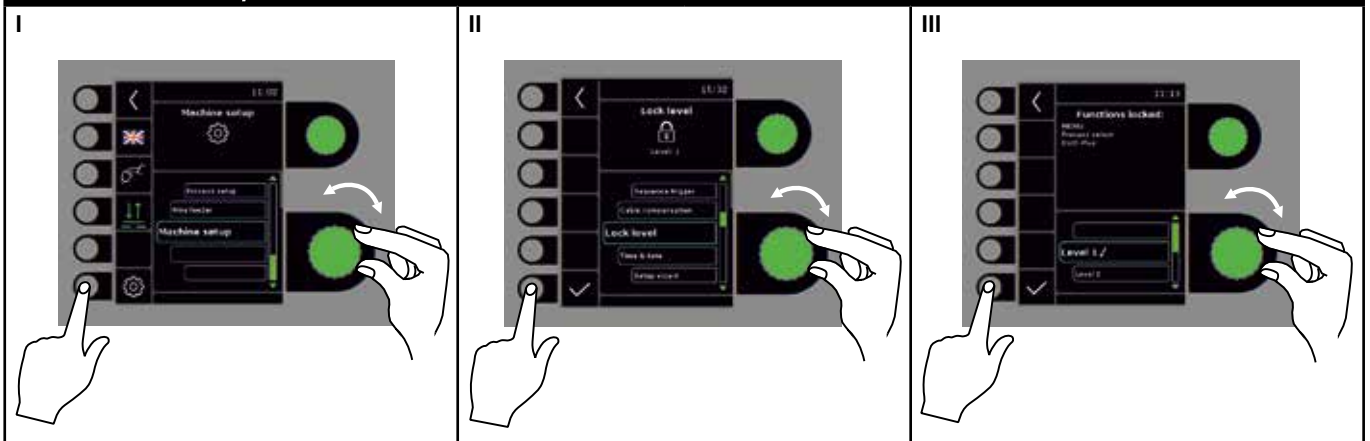

GRAPHICAL - Funzioni speciali

Software / Licenze

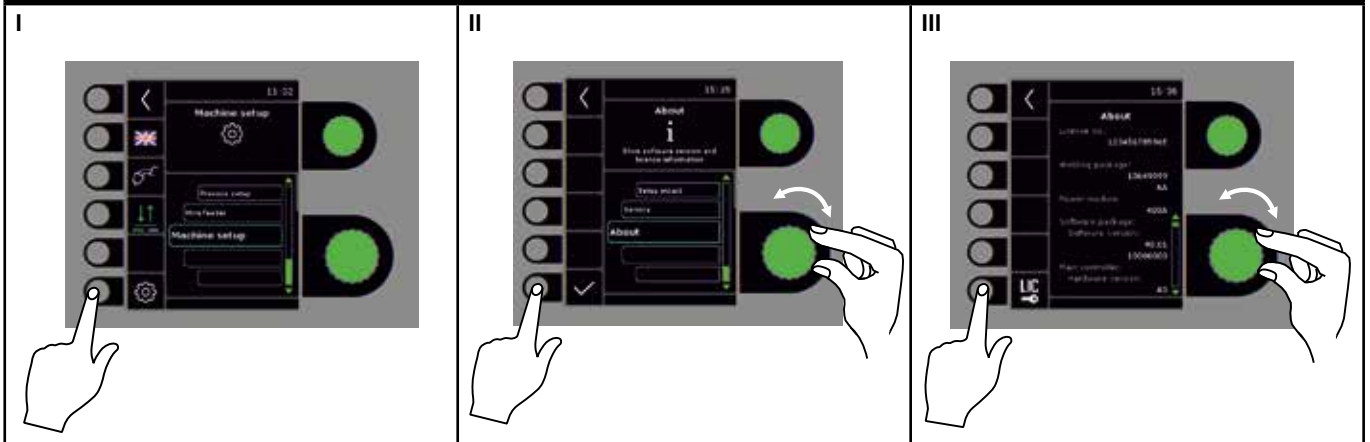

Compensazione fascio cavi (calibrazione della resistenza del fascio cavi)

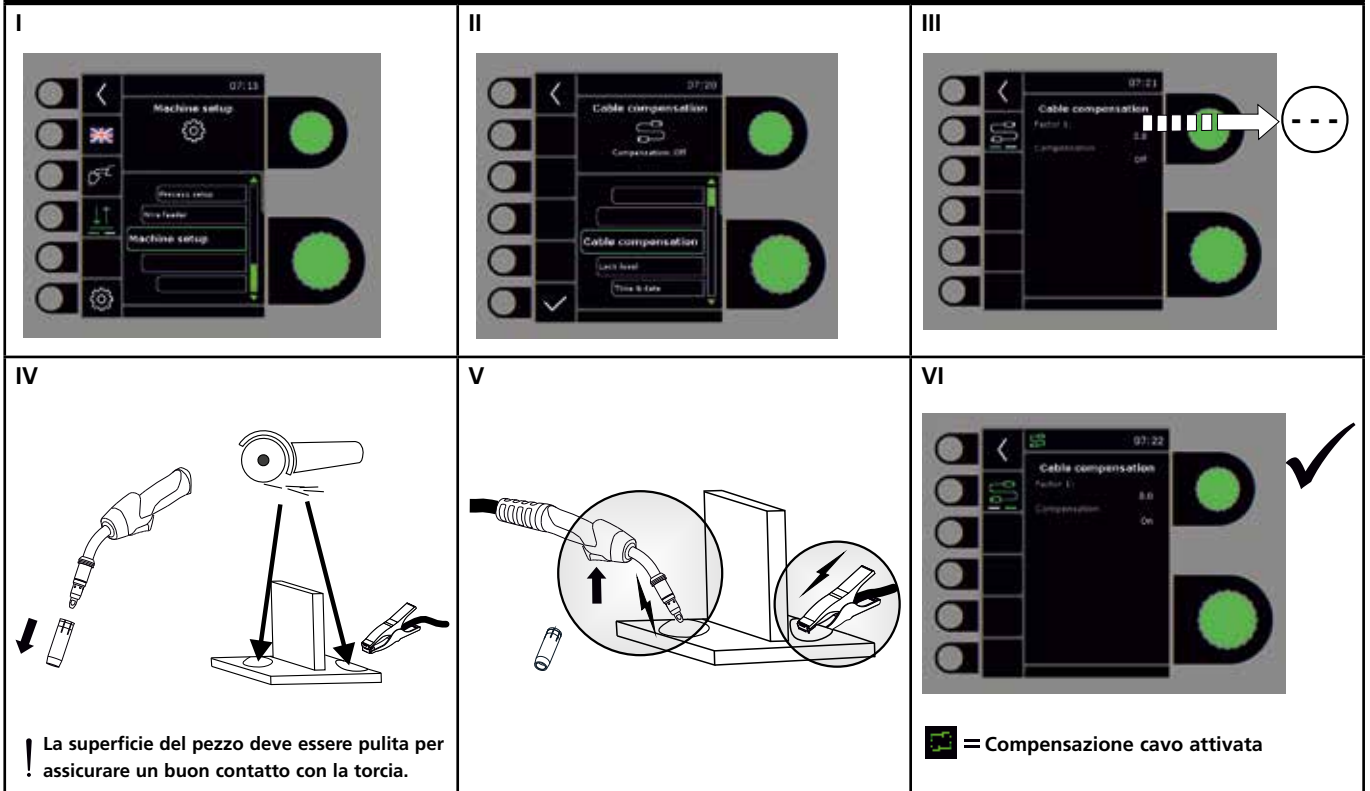

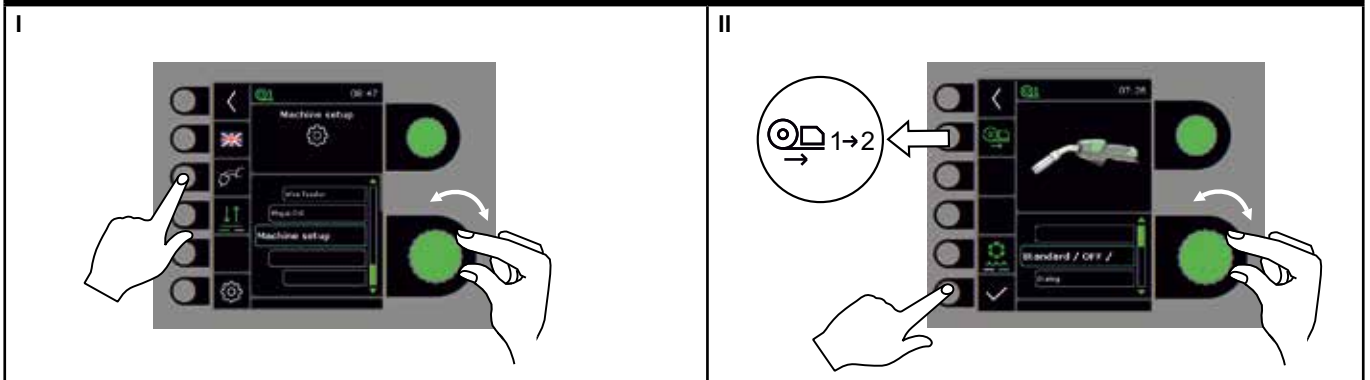

Configurazione Torcia

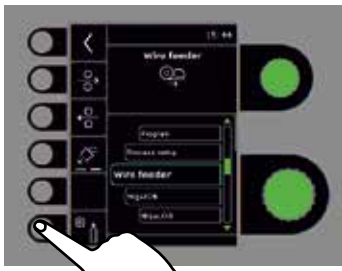

GRAPHICAL - Funzioni speciali

Calibrazione del flusso di gas (non presente in tutti i modelli)

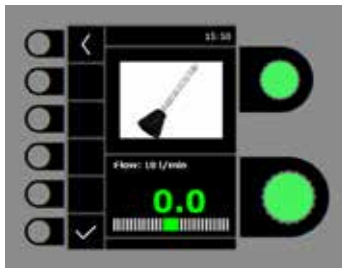
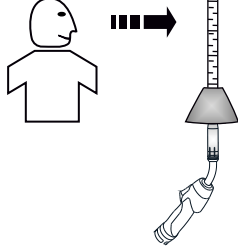
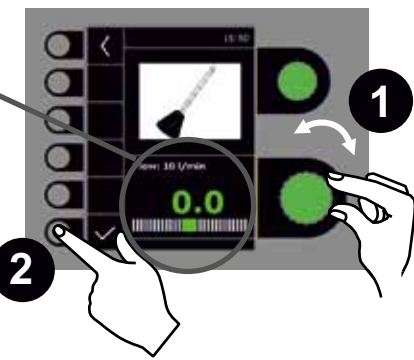
I  <p>A hand icon points to the 'Flow Function' option in the menu.</p>	II  <p>A hand icon points to the 'Gas flow - IGC' screen.</p>	III  <p>The screen displays 'Flow: 10 L/min' and '0.0'.</p>
IV  <p>Diagram illustrating the calibration process using a syringe. The syringe is held vertically, and the flow rate is measured. The diagram shows two measurements: $10 \frac{L}{min} = 10 \frac{L}{min}$ and $20 \frac{L}{min} = 20 \frac{L}{min}$.</p>	V  <p>A hand icon points to the 'Flow' knob on the device. A magnifying glass shows the '0.0' value on the screen. A hand icon points to the 'Flow' knob, labeled '1'. A hand icon points to the 'Flow' knob, labeled '2'.</p>	

GRAPHICAL - Gestione errori

SIGMA Select ha un sofisticato sistema di autoprotezione. In caso di allarme la macchina interrompe automaticamente il gas il filo e la corrente.

Esempi di errore :

Allarme raffreddamento torcia

Questo errore viene indicato solo nelle machine dotate di flussostato in caso di mancata circolazione acqua. Controllate che i tubi siano correttamente collegati, riempire il serbatoio dell'acqua e controllare la torcia.

Se la viscosità del liquido di raffreddamento si riduce a causa delle basse temperature, il liquido di raffreddamento standard Migatronic deve essere sostituito con il liquido di raffreddamento 99290515 BTC-20 NF, che si caratterizza per la sua conducibilità estremamente bassa e l'elevata viscosità fino a temperature di -17°C.

Lavare il sistema prima di aggiungere un nuovo tipo di refrigerante.

L'allarme raffreddamento si cancella schiacciando brevemente il tasto ✓ .





Errore gas (IGC)

L'errore è dovuto a pressione del gas troppo bassa o troppo alta. Assicurarsi che la pressione d'uscita del gas sia compresa tra 2 e 6 bar, corrispondenti a 5 e 27 l/min.

L'allarme viene spento premendo brevemente il tasto ✓ .

Nota: è importante che durante la saldatura venga mantenuta la fornitura di gas indicata.

Registrazione errori

<p>I</p>  <p>11:02 Machine setup Process setup Wire feeder Machine setup</p>	<p>II</p>  <p>11:10 Service Error & date Error record Service About</p>	<p>III</p>  <p>11:10 Error log Error log Error log Error log Error log</p>
<p>IV</p> <h3>Registrazione errori</h3> <p>Tutti gli errori verificatisi sono salvati in una memoria nel Menù Service. Tali errori possono anche essere memorizzati su carta SD inserendo la carta e schiacciando il tasto seguente : A questo punto gli errori sono salvati sulla carta SD. Schiacciando il tasto che indica il cestino la memoria errori viene svuotata.</p>	 <p>11:22 E18-17 Error info 18/04/2015 - 18:44:41 Description Please call Migatronic Service and inform about the error code (E18-17). E18-17 214.15</p>	

Dati tecnici 1

GENERATORE SIGMA Select	300		300 IAC		400		400 IAC		550	
Tensione alimentazione $\pm 15\%$ (50-60Hz), V	3x400		3x400		3x400		3x400		3x400	
Dimensione minima generatore, kVA	16		19		27		29		40	
¹⁾ Minima Potenza Corto-circuito Ssc, MVA	3,7		4,3		6,0		6,0		9,5	
Fusibile, A	16		16		20		20		35	
Corrente primaria effettiva, A	11,0		16,0		17,5		16,5		27,2	
Corrente primaria max., A	15,4		18,3		26,0		28,2		39,2	
Assorbimento 100%, kVA	9,0		11,1		12,1		11,4		18,9	
Assorbimento max., kVA	10,7		12,7		18,0		19,5		27,1	
Potenza, circuito aperto, W	11		13		12		13		12	
Rendimento, %	87		85		89		85		90	
Fattore di potenza	0,90		0,90		0,90		0,90		0,90	
	MIG	MMA	MIG	MMA	MIG	MMA	MIG	MMA	MIG	MMA
Gamma di corrente, A	15-300	15-250	15-300	15-300	15-400	15-400	15-400	15-400	15-550	15-550
100% intermittenza 20°C, A	290/28,5	250/30,0	300/29,0	300/32,0	345/31,5	345/33,8	310/29,5	310/32,5	475/37,8	475/39,0
Max. intermittenza 20°C, A/%V					400/65/34,0	400/65/36,0	400/60/34,0	400/60/36,0	550/60/41,5	550/60/42,0
100% intermittenza 40°C, A/V	220/25,0	220/28,8	270/27,5	270/30,8	300/29,0	300/32,0	280/28,0	280/31,2	430/35,5	430/37,2
60% intermittenza 40°C, A/V	240/26,0	230/29,2			370/32,5	370/34,8	350/31,5	350/34,0	510/39,5	510/40,4
Max. intermittenza 40°C, A/%V	300/25/29,0	250/40/30,0	300/80/29,0	300/80/32,0	400/50/34,0	400/45/36,0	400/40/34,0	400/40/36,0	550/50/41,5	550/50/42,0
Tensione a vuoto, V	50-60		65-70		65-70		65-70		75-80	
²⁾ Classe di applicazione, C // S	S/CE // S/CE		S/CE // S/CE		S/CE // S/CE		S/CE // S/CE		S/CE // S/CE	
³⁾ Classe protezione	IP23S		IP23		IP23		IP23		IP23	
Norme, C	IEC60974-1, IEC60974-5, IEC60974-10 Cl. A									
Norme, S	IEC60974-1, IEC60974-10 Cl. A									
Dimensioni C (AxLxP), mm	700x260x735		700x260x735		700x260x735		700x260x735		700x260x735	
Dimensioni S (AxLxP), mm	454x260x735		454x260x735		454x260x735		454x260x735		454x260x735	
Peso C / S, kg	36,9 / 26		53 / 36		52 / 35		53 / 36		53 / 36	

GENERATORE SIGMA Select	300 Boost				300 IAC Boost			
Tensione alimentazione $\pm 10\%$ (50-60Hz), V	3x208-380				3x380-440			
Dimensione minima generatore, kVA	16				25			
¹⁾ Minima Potenza Corto-circuito Ssc, MVA	1,7				3,75			
Fusibile, A	20				16			
Corrente primaria effettiva, A	19,5				10,6			
Corrente primaria max., A	31,6				16,2			
Assorbimento 100%, kVA	7,1				7,0			
Assorbimento max., kVA	11,0				10,6			
Potenza, circuito aperto, W	45				16			
Rendimento, %	82				87			
Fattore di potenza	0,95				0,95			
	MIG	MMA	MIG	MMA	MIG	MMA	MIG	MMA
Gamma di corrente, A	15-300	15-250	15-300	15-250	15-300	15-300	15-300	15-300
100% intermittenza 20°C, A/V	250/26,5		250/26,5		300/29,0	300/32,0	300/29,0	300/32,0
Max. intermittenza 20°C, A/%V	300/40/29,0		300/40/29,0					
100% intermittenza 40°C, A/V	200/24,0	200/28,0	200/24,0	200/28,0	250/26,5	220/28,8	250/26,5	220/28,8
60% intermittenza 40°C, A/V	210/24,5	210/28,4	210/24,5	210/28,4	270/27,5	250/30,0	270/27,5	250/30,0
Max. intermittenza 40°C, A/%V	300/25/29,0	250/35/30,0	300/25/29,0	250/35/30,0	300/35/29,0	300/30/32,0	300/35/29,0	300/30/32,0
Tensione a vuoto, V	50-60				70-75			
²⁾ Classe di applicazione, C // S	S/CE // S/CE				S/CE // S/CE			
³⁾ Classe protezione	IP23S				IP23			
Norme, C	IEC60974-1, IEC60974-5, IEC60974-10 Cl. A				IEC60974-1, IEC60974-5, IEC60974-10 Cl. A			
Norme, S	IEC60974-1, IEC60974-10 Cl. A				IEC60974-1, IEC60974-10 Cl. A			
Dimensioni C (AxLxP), mm	700x260x735				900x260x735			
Dimensioni S (AxLxP), mm	454x260x735				654x260x735			
Peso C / S, kg	45 / 34				66 / 49			

1) Questa macchina è conforme alla norma EN / IEC61000-3-12:2014 (/ 2011) a condizione che la potenza di corto-circuito della rete Ssc nel punto di alimentazione sia superiore o uguale al valore indicato nella tabella. E' responsabilità dell'utilizzatore o dell'installatore, eventualmente consultando il distributore di energia elettrica, che la macchina sia collegata solo ad un'alimentazione con una potenza di corto-circuito Ssc uguale o superiore al valore indicato nella tabella.

2) S La macchina è conforme agli standard per impianti destinati a lavorare in ambienti ad alto rischio elettrico.

3) La macchina è progettata per uso interno ed esterno secondo la classe di protezione IP23 / IP23S.

IP23S: la macchina può essere conservata ma non è concepita per essere utilizzata all'esterno durante le precipitazioni a meno che non sia riparata.

Dati tecnici 2

GENERATORE SIGMA Select	400 Boost				400 IAC Boost			
Tensione alimentazione $\pm 10\%$ (50-60Hz), V	3x208-380		3x380-440		3x208-380		3x380-440	
Dimensione minima generatore, kVA	25		25		25		25	
¹⁾ Minima Potenza Corto-circuito Ssc, MVA					4,0		4,0	
Fusibile, A	25-50		25-50		25-50		25-50	
Corrente primaria effettiva, A	22,0		11,7		24,8		11,8	
Corrente primaria max., A	45,0		23,5		48,0		24,5	
Assorbimento 100%, kVA	8,3		8,1		8,5		8,5	
Assorbimento max., kVA	16,7		16,3		17,4		17,4	
Potenza, circuito aperto, W	60		56		60		71	
Rendimento, %	84		88		82		85	
Fattore di potenza	0,96		0,95		0,96		0,96	
	MIG	MMA	MIG	MMA	MIG	MMA	MIG	MMA
Gamma di corrente, A	15-400	15-400	15-400	15-400	15-400	15-400	15-400	15-400
100% intermittenza 20°C, A/V	300/29,0	300/32,0	300/29,0	300/32,0	300/29,0	300/32,0	300/29,0	300/32,0
Max. intermittenza 20°C, A/%V	400/30/34,0	400/30/32,0	400/30/34,0	400/30/32,0	400/30/34,0	400/30/32,0	400/30/34,0	400/30/32,0
100% intermittenza 40°C, A/V	250/26,5	220/28,8	250/26,5	220/28,8	250/26,5	220/28,8	250/26,5	220/28,8
60% intermittenza 40°C, A/V	280/28,0	260/30,4	280/28,0	260/30,4	280/28,0	260/30,4	280/28,0	260/30,4
Max. intermittenza 40°C, A/%V	400/25/34,0	400/20/36,0	400/25/34,0	400/20/36,0	400/25/34,0	400/20/36,0	400/25/34,0	400/20/36,0
Tensione a vuoto, V	70-75				70-75			
²⁾ Classe di applicazione, C // S	S/CE // S/CE				S/CE // S/CE			
³⁾ Classe protezione	IP23				IP23			
Norme, C	IEC60974-1, IEC60974-5, IEC60974-10 Cl. A				IEC60974-1, IEC60974-5, IEC60974-10 Cl. A			
Norme, S	IEC60974-1, IEC60974-10 Cl. A				IEC60974-1, IEC60974-10 Cl. A			
Dimensioni C (AxLxP), mm	900x260x735				900x260x735			
Dimensioni S (AxLxP), mm	654x260x735				654x260x735			
Peso C / S, kg	66 / 49				67 / 50			

TRAINAFILO MWF			
Velocità filo, m/min	0,5-30,0		
Attacco torcia	EURO		
Diametro bobina, mm	300		
Bobina di filo, kg	5-18		
100% intermittenza 40°C, A/%	430		
60% intermittenza 40°C, A/%	500		
Max. intermittenza 40°C A/%	550/50		
³⁾ Classe protezione	IP23		
Diametro filo, mm	0,6-1,6		
Pressione gas, MPa (bar)	0,6 (6,0)		
	MWF 30	MWF 32	MWF 33
Dimensioni (AxLxP), mm	413x310x750	457x260x672,5	457x260x672,5
Peso, kg	11,6	14,0	14,0
Norme	IEC60974-5, IEC60974-10 CL. A		

UNITÀ DI RAFFREDDAMENTO MCU 1300	
Efficienza di raffreddamento (1 l/min), W	1300
Efficienza di raffreddamento (1,5 l/min), W	1600
Capacità serbatoio, litri	5
Portata, bar - °C - l/min	3,0-60-1,5
Pressione max., bar	5
Norme	IEC60974-2, IEC60974-10 CL.A
Dimensioni (AxLxP), mm	207x260x680
Peso	20

DICHIARAZIONE DI CONFORMITÀ	
	
MIGATRONIC A/S Aggersundvej 33 9690 Fjerritslev Denmark	
Con la presente si dichiara che la nostra macchina Tipo: SIGMA Select	
conforme alle direttive: 2014/35/EU 2014/30/EU 2011/65/EU	
Standard Europei: EN IEC60974-1:2018/A1:2019 EN IEC60974-2:2019 EN IEC60974-5:2019 EN / IEC60974-10:2014/A1:2015	
Regolamento: 2019/1784/EU	
Emesso in Fjerritslev 10.02.2021	
 Kristian M. Madsen CEO	

- Questa macchina è conforme alla norma EN / IEC61000-3-12:2014 (/ 2011) a condizione che la potenza di corto-circuito della rete Ssc nel punto di alimentazione sia superiore o uguale al valore indicato nella tabella. E' responsabilità dell'utilizzatore o dell'installatore, eventualmente consultando il distributore di energia elettrica, che la macchina sia collegata solo ad un'alimentazione con una potenza di corto-circuito Ssc uguale o superiore al valore indicato nella tabella.
- La macchina è conforme agli standard per impianti destinati a lavorare in ambienti ad alto rischio elettrico.
- La macchina è progettata per uso interno ed esterno secondo la classe di protezione IP23 / IP23S.
IP23S: la macchina può essere conservata ma non è concepita per essere utilizzata all'esterno durante le precipitazioni a meno che non sia riparata.

Aansluiting en bediening

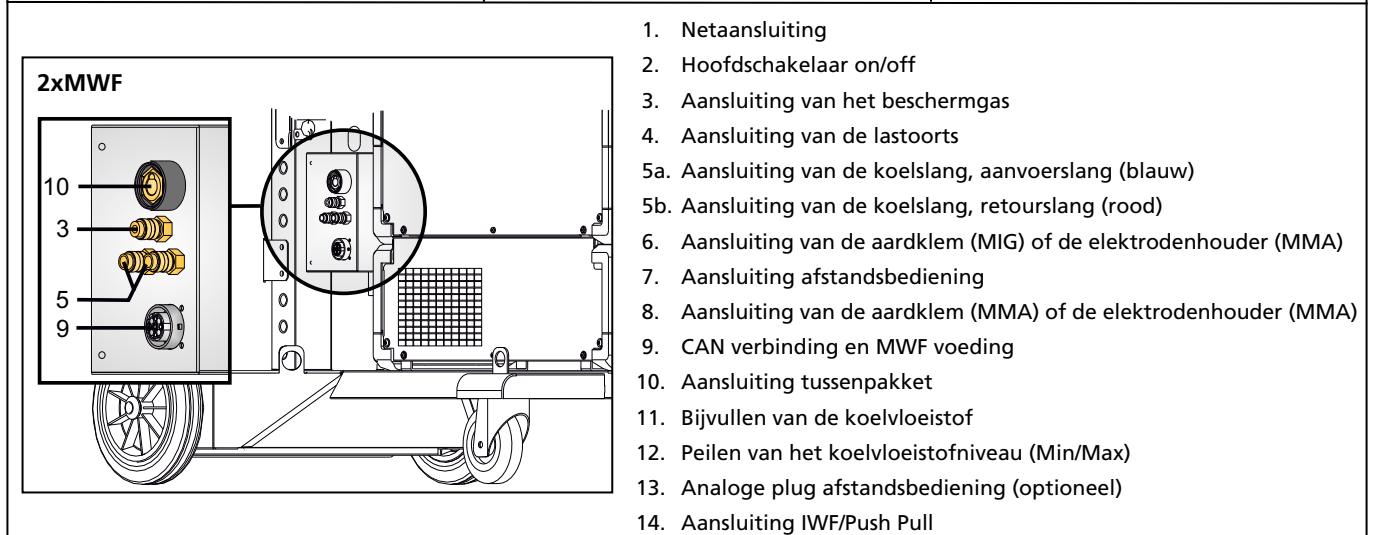
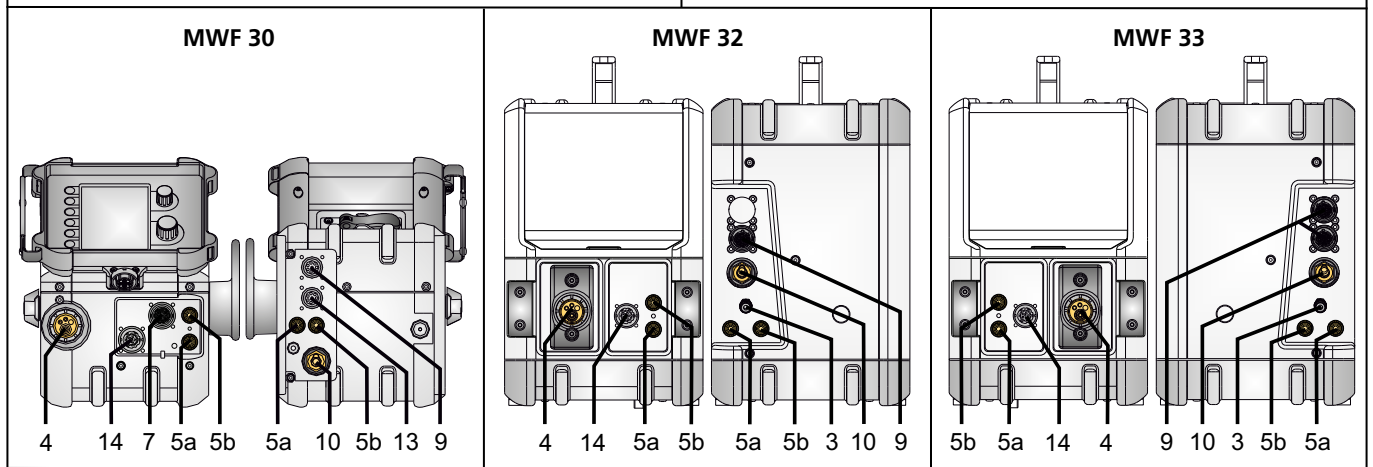
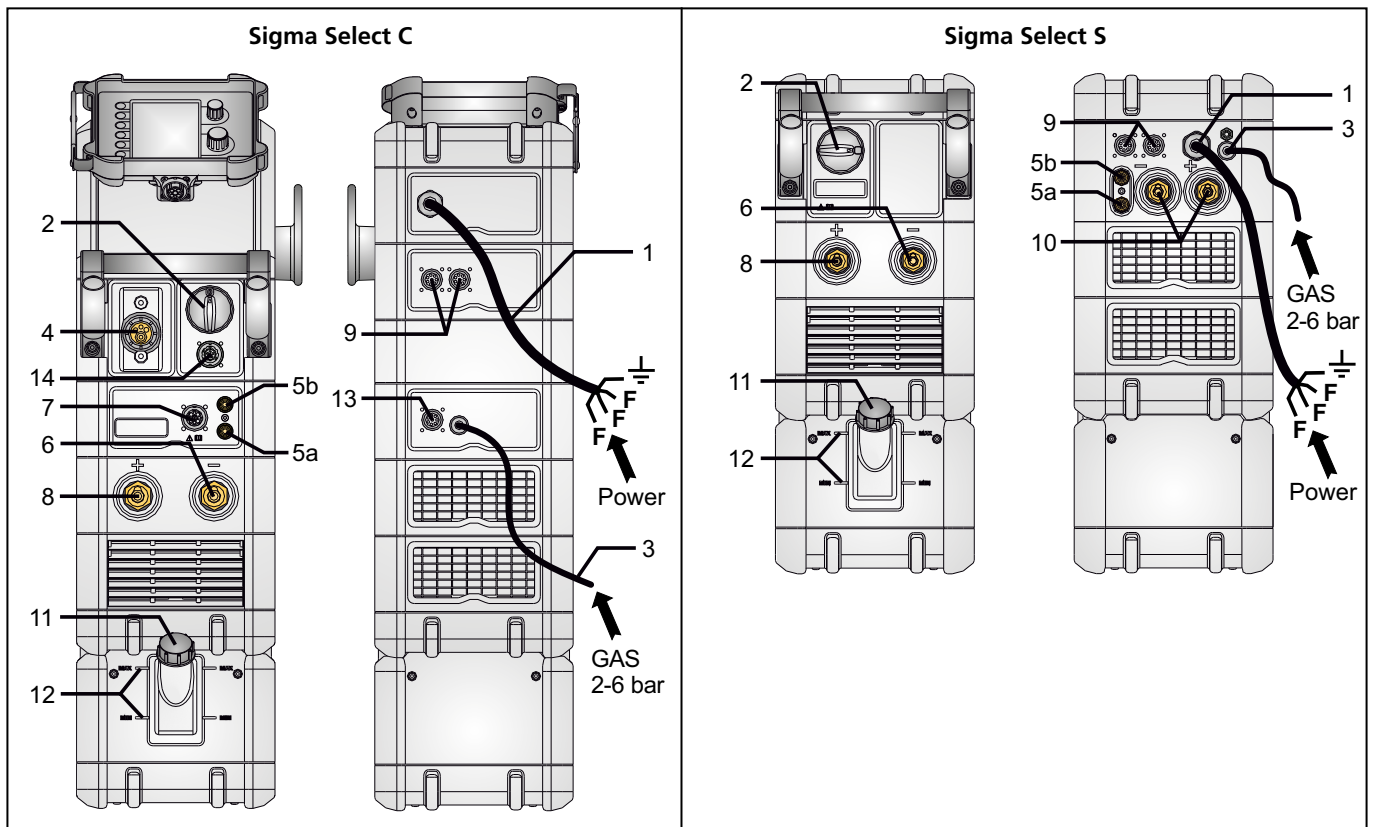

Aansluiting en bediening



Waarschuwing

Lees de waarschuwingen en deze gebruikershandleiding zorgvuldig door voordat u de apparatuur aansluit en in gebruik neemt en bewaar de informatie eventueel voor gebruik later.

Toegestane installatie

Netaansluiting

Sluit de machine op de juiste netvoeding aan. Lees ook het typeplaatje (U,) aan de achterkant van de machine.

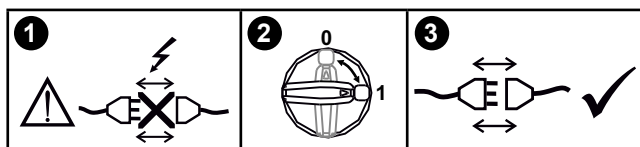
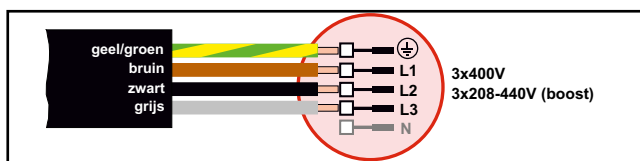

Voltage Stabilisatie kit

De stroombron is configureerbaar met een spanningsstabilisatie kit ter beveiliging tegen grotere spanningsvariaties, bijvoorbeeld bij gebruik van een generator wanneer de machine is aangesloten op een aparte voeding.

Aansluiting van het beschermgas

De gas slang wordt aangesloten op het achterpaneel van de stroombron (3), en verbonden met de gasvoorziening met een gasdruk van 2-6 bar. (Opmerking: sommige soorten drukregelaars vereisen een uitgang gasdruk van meer dan 2 bar om optimaal te functioneren). Een/twee gascilinders kunnen geplaatst worden op de flessendrager aan de achterkant van het onderstel.

Gasverbruik

Afhankelijk van het te lassen product, gassoort en ontwerp van de lasnaad, zal het gasverbruik variëren van 6-7 l/min bij lage ampèrage (<25A) tot 27 l/min bij maximale ampèrage.

Materiaalverbruik

Materiaalverbruik (gewicht) kan worden geschat door het product te berekenen van de lastijd (min), de draaddoorvoersnelheid (m/min) en het gewicht per meter van de gebruikte lasdraad.

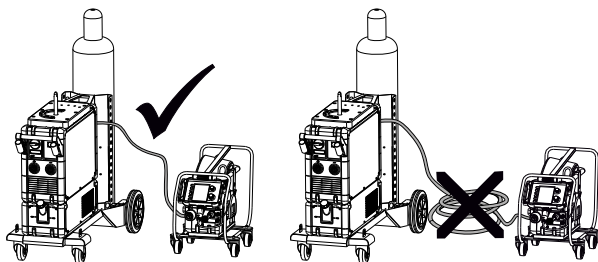

WAARSCHUWING

Als de schakelaar van de lastoorts wordt ingedrukt, komt de lasdraad/elektrode onder spanning te staan.

Lastoorts aansluiten

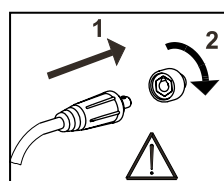
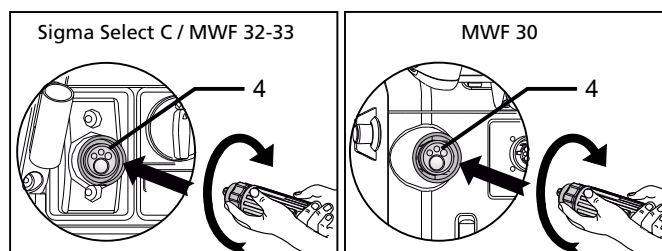

Belangrijk!

Om, wanneer aardkabels en lastoortsen aan de machine worden aangesloten, schade aan pluggen en kabels te voorkomen, is een goed elektrisch contact vereist. (zie tekening).

Aansluiting laskabel bij MMA

De las- en aardkabel moeten worden aangesloten op resp. de zitting + (10) en - (8). Raadpleeg de instructies van de elektrodenleverancier bij het selecteren van polariteit.

Aanbevolen kabeldiktes

Lasstroom	DC	PULS
200 A	35 mm ²	35 mm ²
300 A	50 mm ²	70 mm ²
400 A	95 mm ² / 2x50 mm ²	95 mm ² / 2x50 mm ²
550 A	2x70 mm ²	2x70 mm ²

Lasproces	Afstand tot werkstuk (a+b)	Totale kabellengte van het lascircuit (a+b+c)
MIG - IAC en puls	10 m	20 m
MIG - geen puls	30 m	60 m

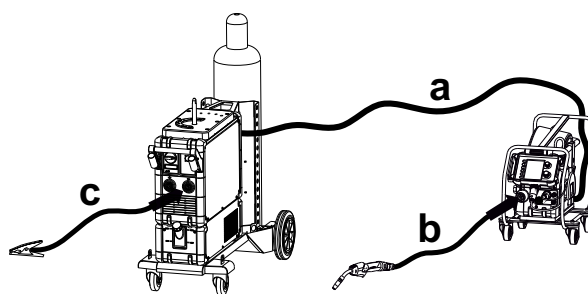

Afstellen van draadhaspelrem

De draadrem moet ervoor zorgen dat de draadhaspel voldoende afremt om te voorkomen dat de draad van de haspel afloopt. De remkracht is afhankelijk van het gewicht van de haspel en de draadsnelheid. De fabrieksinstelling is 15 kg.

Afstellen:

- Verwijder de regelknop door een dunne schroevendraaier achter de knop te plaatsen en deze vervolgens uit te duwen.
- Stel de draadrem af door de zelfborgende moer op de as van de haspelhouder vast of losser te draaien.
- Druk de knop terug.

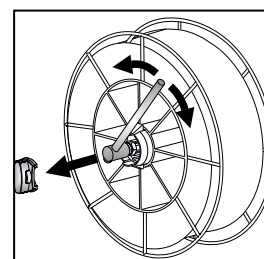

Aansluiting en bediening

Hefinstructies

Het hefpunt moet gebruikt worden zoals aangegeven in de volgende tekening. De machine mag niet worden opgetild wanneer er een gasfles is aangesloten. (Zie tekening).

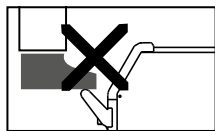
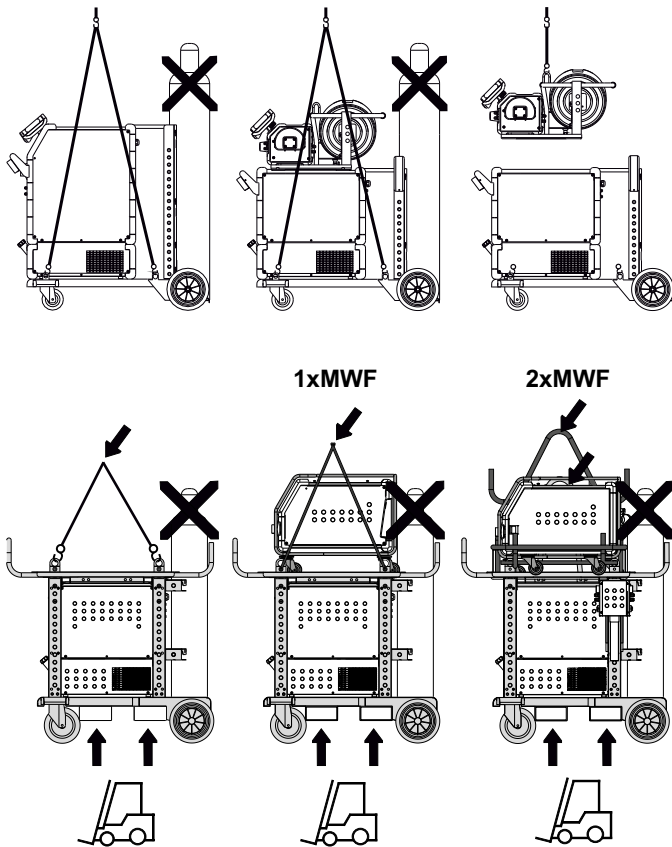

Til de machine niet op met de handgreep. Ga niet op de handgreep staan.

Montage afstandsbediening

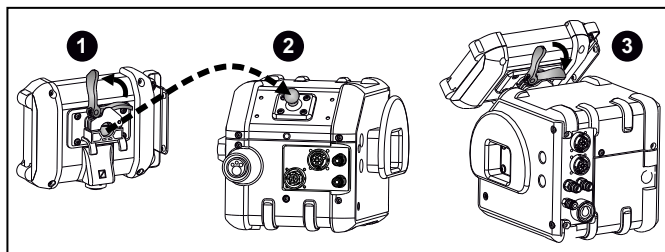

MWF 30 draadhaspel

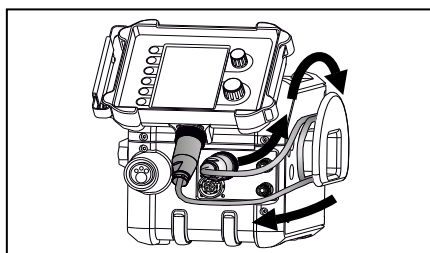

MCU ventilatie

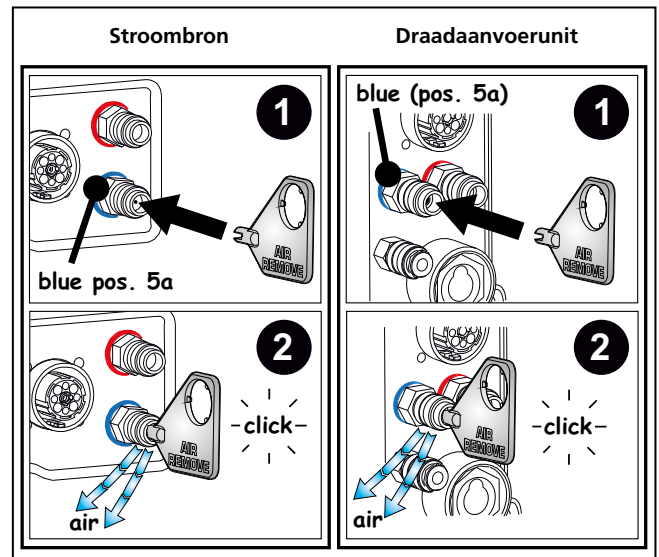

MWF sluit-draaifunctie

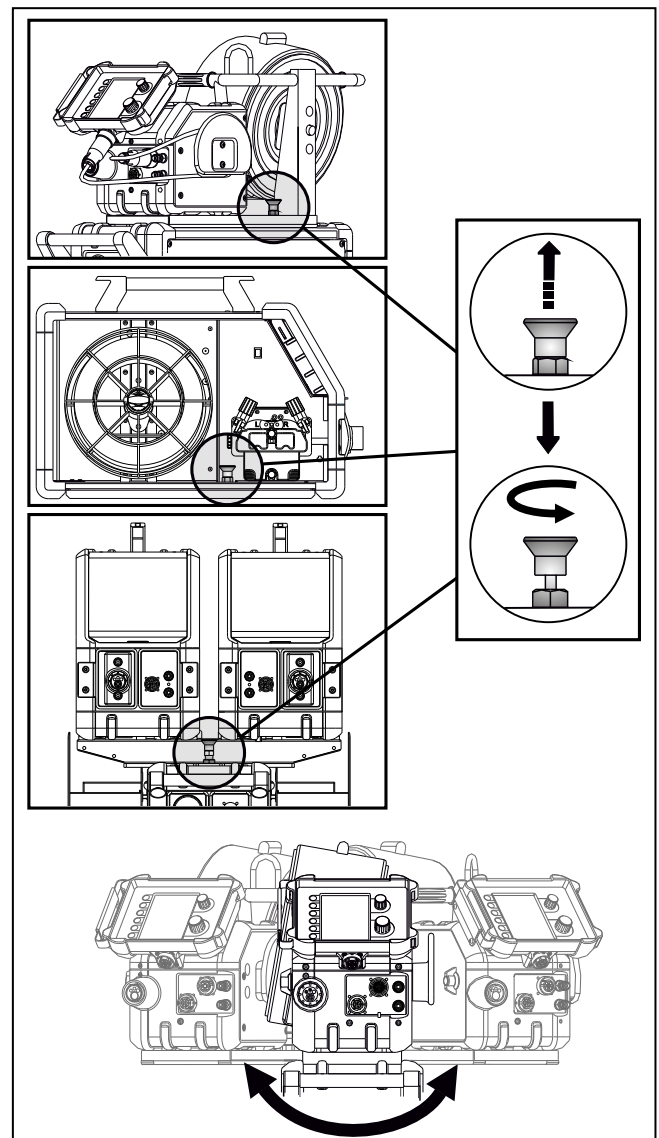

Aansluiting en bediening

Assembleren van onderdelen in de draadaanvoerunit

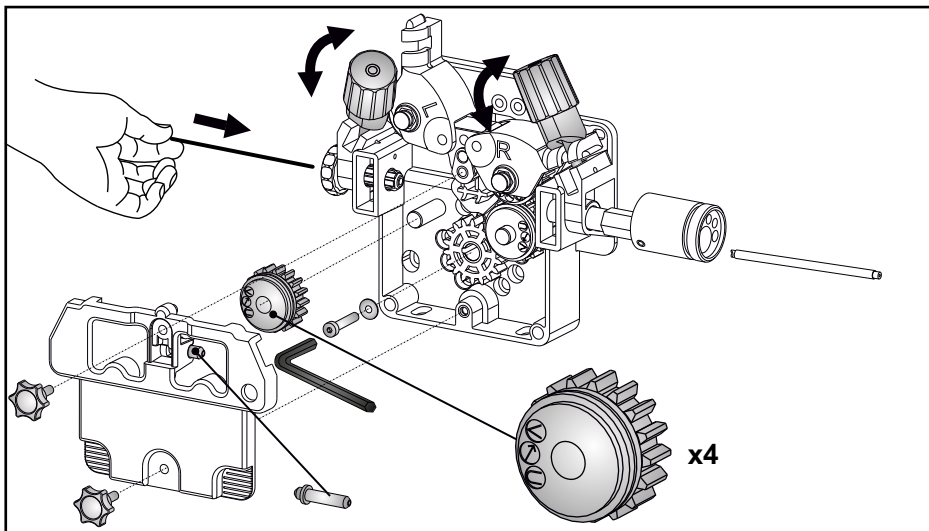

Met behulp van de kartelmoer op de spanbout wordt de druk op de transportrollen dusdanig ingesteld, dat een gelijkmatige draadaanvoer wordt bewerkstelligt zonder vervorming van de draad.

Draadinvoer vooruit/achteruit

Wanneer er niet wordt gelast, kan de draaddoorvoer worden geactiveerd door een van de toetsen in te drukken of kan worden geactiveerd door de robot-interface, als de MWF 30 draadaanvoerunit wordt gebruikt in een robot-opstelling.

Draadinvoer

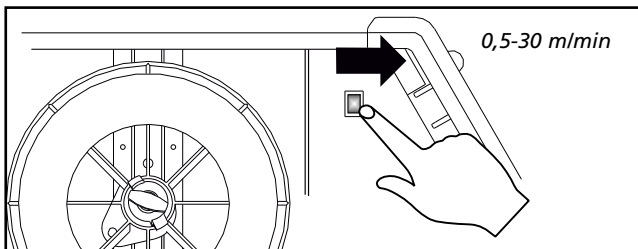

Draadinvoer MWF 30

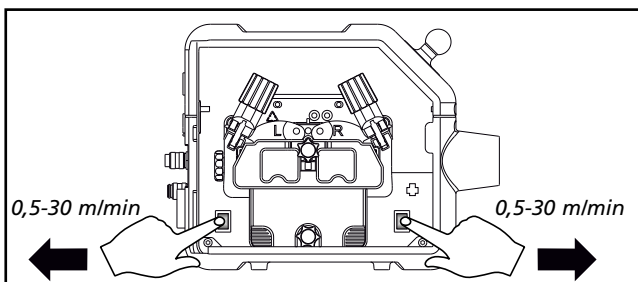

Draadinvoer Graphical

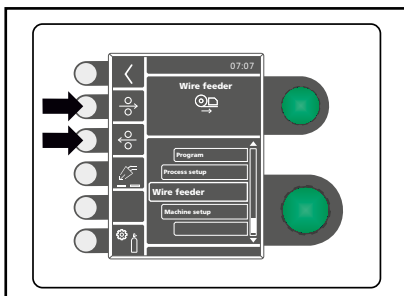

Software update

- Schuif de SD-kaart in.
- Schakel de machine in.
- Wacht tot de unit aangeeft dat de update gereed is.
- Schakel de machine uit en verwijder de SD kaart.
- De machine is nu klaar voor gebruik.

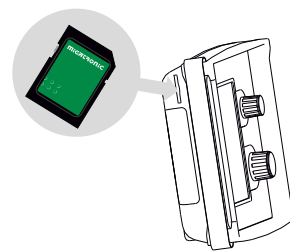

Nieuwe software wordt geladen in de krachtbron en alle aangesloten units.

De software kan worden gedownload via <http://migatron.com> naar een SD-kaart. Het bestandssysteem van de SD-kaart moet worden geformatteerd naar FAT32.

BELANGRIJK:

Sla de software op in de //MIGA_SW/SIGMA/ bestandsstructuur.

SW-licentie

Als er extra licenties voor programma's of speciale functies zijn gekocht, moeten de MigaLic.dat-bestanden door de machine op dezelfde manier worden gelezen als SW-pakketten. Denk eraan een backup file op te slaan.

Het MigaLic.txt-bestand bevat informatie over het licentie-nummer van de machine en de licenties op de SD-kaart.

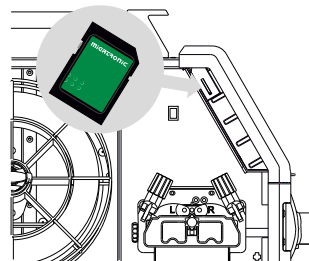

BASIC - Speciale functies

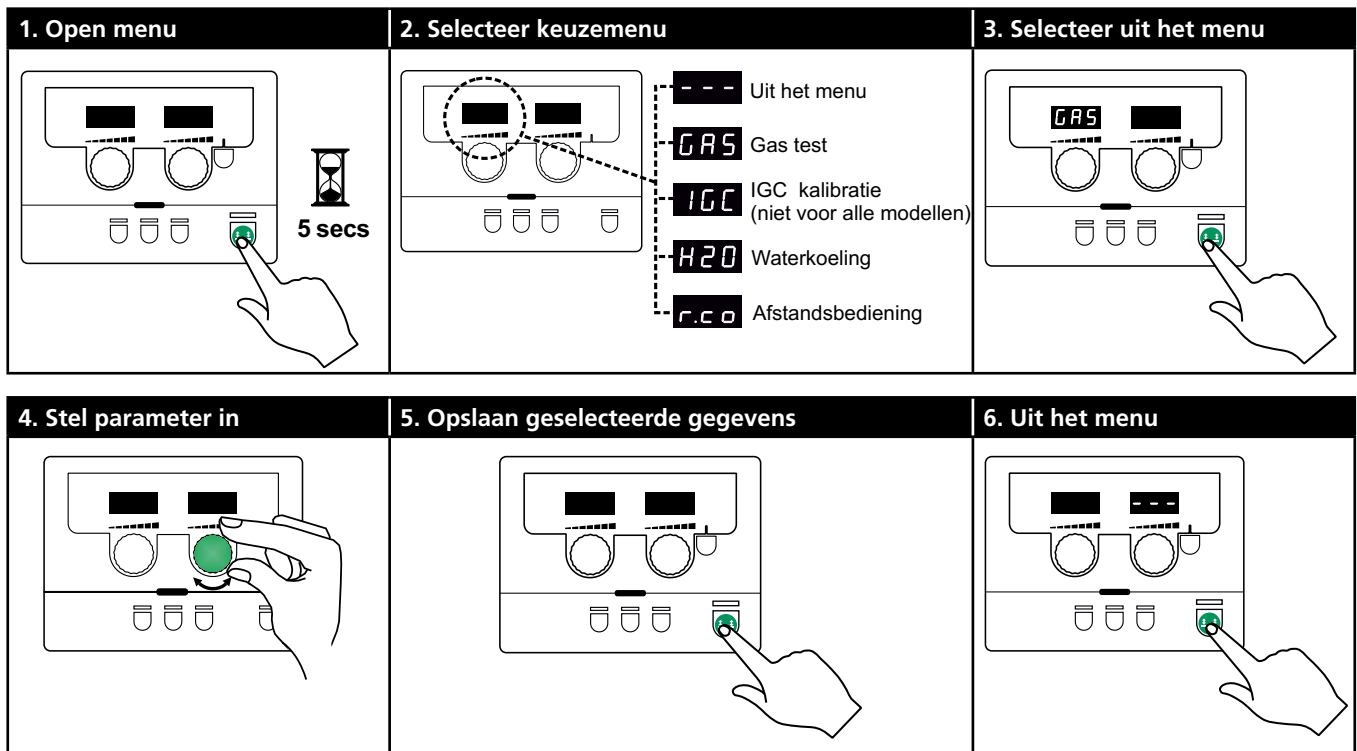

Parameters en menu keuze

Druk de -toets in tot het gebruikersmenu opent. Draai de linker draaiknop tot het vereiste menu wordt getoond. Gebruik de rechter draaiknop om de instellingen te veranderen in de rechter display. Druk kort op de -toets om functies zoals gastest te activeren.

Functies en parameters in het gebruikersmenu:

--- **GAS** **IGC** **H2O** **r.c.o**

--- Druk op de -toets om het menu te verlaten

GAS GAS test
Druk op de -toets om de gasklep te openen en te sluiten. Als een IGC kit is geïnstalleerd, is het mogelijk om de gasdoorstroming te regelen met de rechter draaiknop.

IGC IGC kalibratie
Alleen zichtbaar als IGC kit is geïnstalleerd.
Druk op de -toets om de IGC kalibratie op te starten.

H2O Waterkoeling
Alleen zichtbaar als waterkoelunit is geïnstalleerd.

0: Waterkoeling OFF
1: Waterkoeling ON

r.c.o Instelling afstandsbediening
Gebruik de rechter draaiknop om de volgende instellingen te wijzigen:

0: Uitgeschakeld
1: Toortsregeling (*artikel nr. 80100402*)
2: Analoge afstandsbediening (*artikel nr. 78815029*)

BASIC - Speciale functies

Configuratie voor externe besturing

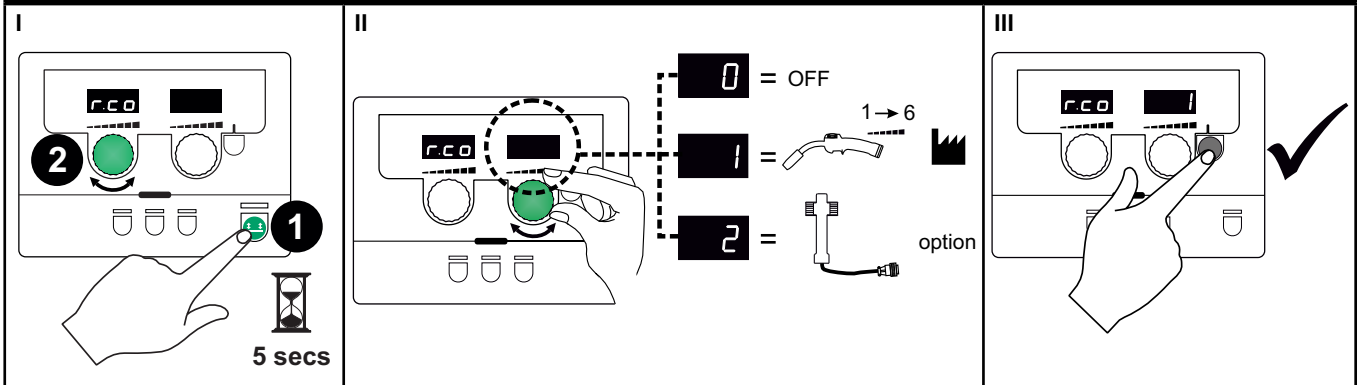

Blokkeerfunctie /

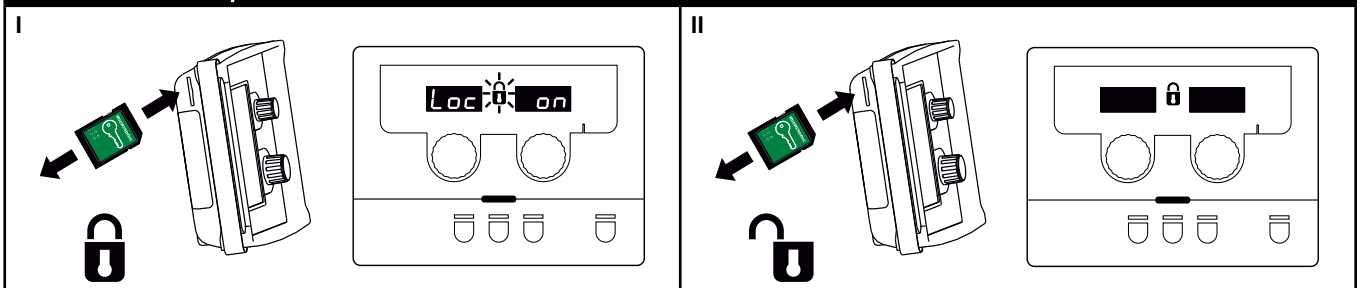

Kalibratie van gasflow (niet alle modellen)

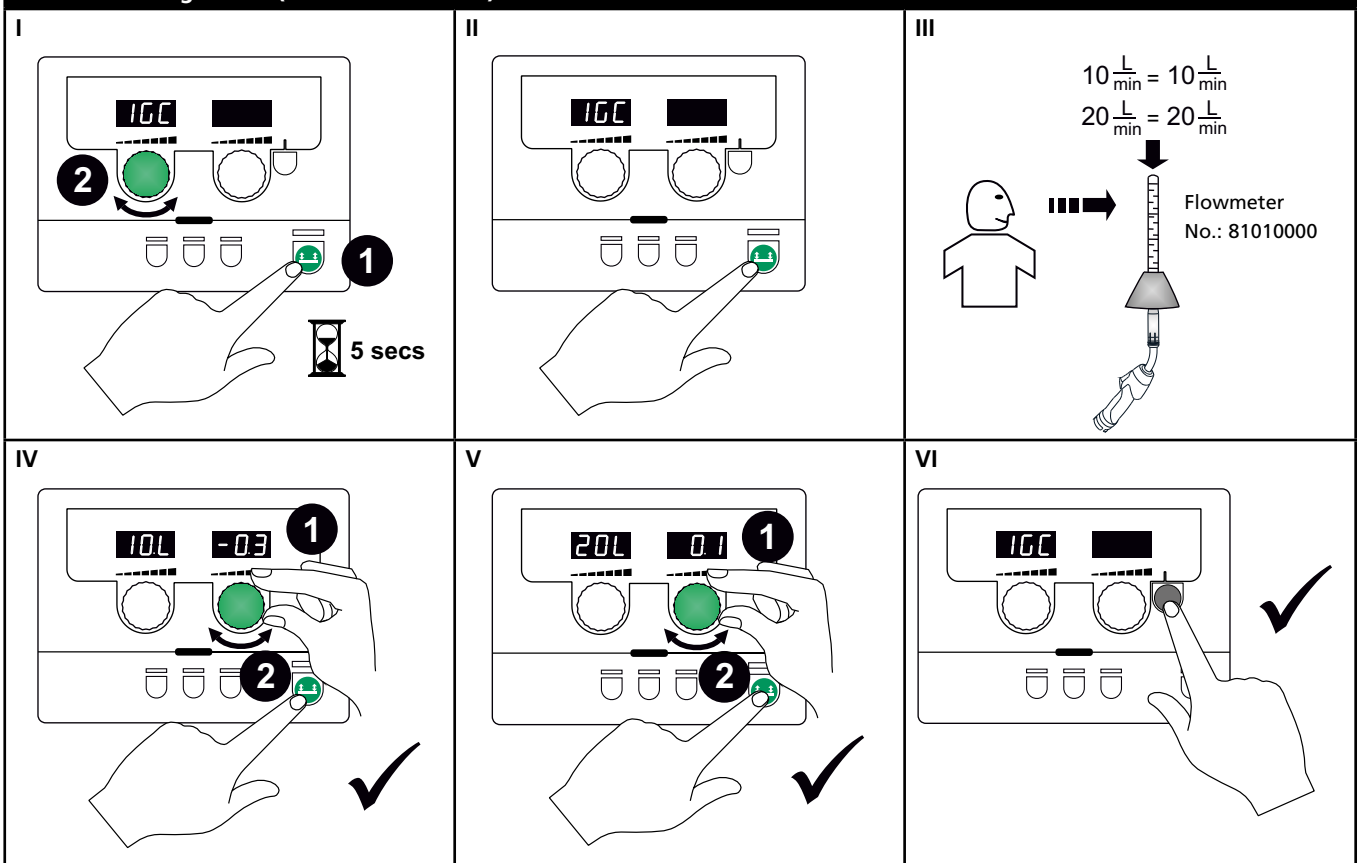

BASIC - Speciale functies

Softwareversies/licentienummer tonen

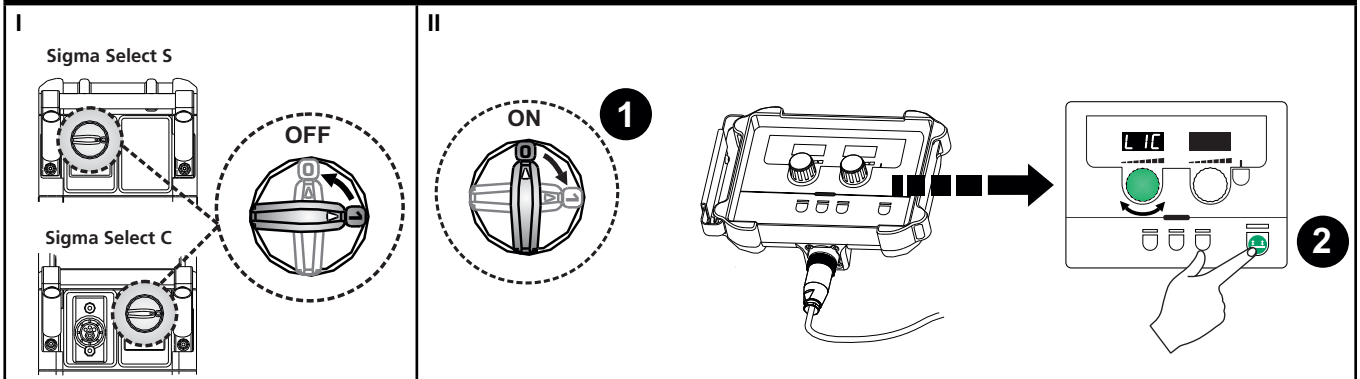

1. Licentienummer

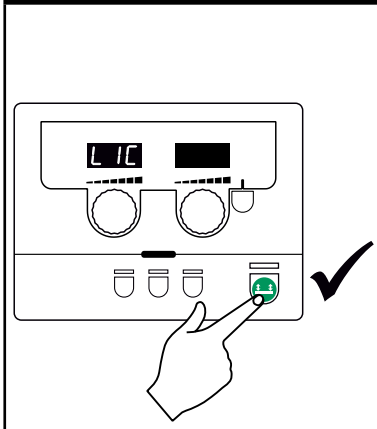

2. Zie licentie nr. (12 cijfers/letters)

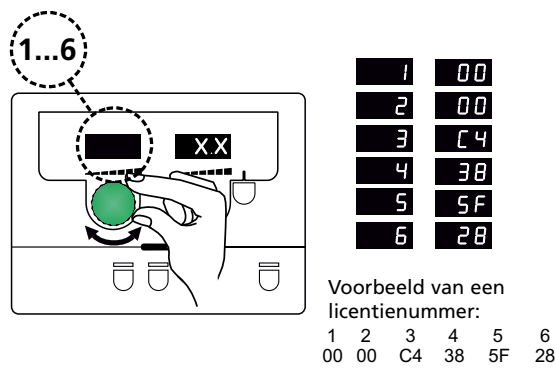

3. Terug naar software versies

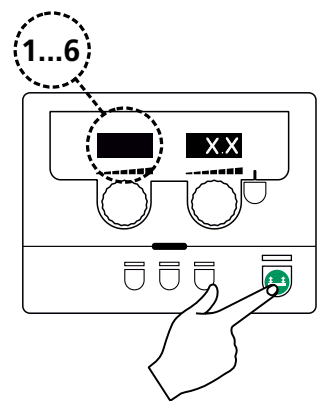

4. Selecteer software

- Basic remote **1**
- Welding package **2**
- Main controller **3**
- "..." **4**
- "..." **5**
- Wire feeder **6**
- Wire feeder **7**
- Arc controller **8**
- "..." **9**
- "..." **10**
- "..." **11**
- "..." **12**
- "..." **13**
- "..." **14**
- "..." **15**
- "..." **16**
- Water controller **17**
- Smart Torch **18**

"..." not supported

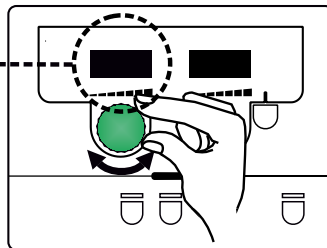

5. Uit het menu

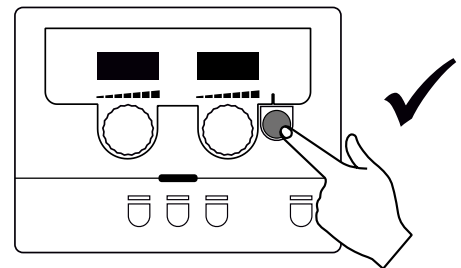

BASIC - Omgaan met fouten

Fout-code	Oorzaak en oplossing
E20-00 E20-02 E21-00 E21-06 E21-08	Er is geen software geplaatst in de besturingsunit Download software naar de SD-kaart, schuif de SD-kaart in de besturingsunit en schakel de machine in. Vervang de SD-kaart, indien noodzakelijk.
E20-01 E21-01	SD kaart is niet geformatteerd De SD-kaart moet als FAT geformatteerd worden in een pc en de software moet naar de SD-kaart worden gedownload. Vervang de SD-kaart, indien noodzakelijk.
E20-03 E21-02	Op de SD kaart staan meer programma's met dezelfde naam Verwijder bestanden op de SD-kaart en laad de software opnieuw.
E20-04	De besturingsunit heeft geprobeerd meer data te lezen dan toegankelijk is in het geheugen Voer de SD kaart opnieuw in of vervang de SD kaart. Neem contact op met MIGATRONIC Service, als dit het probleem niet oplost.
E20-05 E20-06	Software op de SD kaart is geblokkeerd voor een ander type besturingsunit Gebruik een SD kaart met software die overeenkomt met de besturingsunit.
E20-07	De interne kopieerbescherming geeft geen toegang tot de microprocessor Voer de SD kaart opnieuw in of bel MIGATRONIC Service.
E20-08 E20-09 E21-05	De besturingsunit is defect Bel MIGATRONIC Service
E20-10 E21-07	Het opgeladen bestand geeft een foutmelding Voer de SD kaart opnieuw in of vervang de SD kaart.
E21-03 E21-04	Het lasprogrammapakket is niet geschikt voor deze besturingsunit Gebruik een SD kaart met software die overeenkomt met uw besturingsunit.
Err GAS	Gasstoring Controleer de gastoevoer. Annuleer de gasfout door kort een willekeurige knop in te drukken.
E02-04	CAN-communicatiefout Controleer het tussenpakket.
E11-20	Stroomsensorfout 1. Controleer de stroomsensor 2. Bel MIGATRONIC Service.

Fout symbolen

 **Temperatuur fout**
De indicator voor oververhitting licht op wanneer het lassen wordt onderbroken door oververhitting van de machine. Laat de machine aan staan totdat de ventilator de machine voldoende heeft afgekoeld.

 **Stroomfout**
De indicator knippert wanneer de startstroom of lasstroom hoger is dan toegestaan is door de capaciteit van de machine. Zorg ervoor dat draadsnelheid/stroom en spanning juist ingesteld zijn.

 **Foutsymbolen**
De indicator knippert wanneer andere type fouten optreden. Tegelijk wordt de foutcode in het display getoond.

Geselecteerde foutcodes

 **E11 15** **Netspanningsfout**
Het icoon zal oplichten, wanneer de netspanning te hoog is. Sluit de machine aan op 400V AC, +/-15% 50-60Hz.



 **Err H20** **toortscoeling fout**
Koelingsfout indicator licht op door foutieve aansluiting of een verstopping omdat er geen circulatie van de vloeistof plaatsvindt. Controleer of de koelerslangen juist zijn aangesloten, voldoende koelvloeistof aanwezig is, en controleer de lastoorts of aanverwante slangen.

Als de koelvloeistof viscositeit wordt gereduceerd door lage temperaturen, moet de Migatronicon standaard koelvloeistof worden vervangen door 99290515 BTC-20 NF koelvloeistof, die wordt gekenmerkt door zijn extreem lage geleidbaarheid en hoge viscositeit tot temperaturen van -17°C. Spoel het koelsysteem goed door voordat er een nieuwe type koelvloeistof wordt toegevoegd.

De koelingsfout wordt opgeheven door kort de -knop in te drukken.

 **Err GAS** **Gasstoring (IGC)**
Een gasfout is te wijten aan een te lage of te hoge gasflow. Overtuig u ervan dat de druk op de gasflow hoger is dan 2 bar en minder dan 6 bar, wat overeenkomt met resp. 5 l/min en 27 l/min. Deze foutmelding wordt uitgeschakeld door de handmatige gasflow af te stellen op 27 l/min. De gasfout wordt gereset door kort op het -knop te drukken.

Draadaanvoerfout

 **E01 00** of  **E01 01**

Het icoon zal oplichten, wanneer de draadtransportmotor overbelast is. De draadtransportmotor of magneetklep kan defect zijn.

Andere type fouten

Wanneer er andere foutsymbolen in het display getoond worden, moet de machine uitgezet worden om de signalering uit te schakelen. Als het foutsymbool herhaaldelijk getoond wordt, is reparatie van de stroombron gewenst. Neem contact op met uw leverancier over de foutmelding.

Wanneer bijbehorende afzonderlijke apparatuur is aangesloten, kunnen de volgende foutcodes worden getoond:

 **E07 04** wordt getoond wanneer er geen communicatie is tussen de stroombron en de aangesloten unit(s).

 **E07 05** wordt getoond wanneer de motor niet goed draait.

 **E07 06** wordt getoond wanneer de motor overbelast is.

GRAPHICAL - Speciale functies

Wizard instelling

I Language selection screen showing 'English /' selected.

II Date/Time setting screen showing '11:37' and '2017-09-01'.

III Wire feeder setup 1 screen with a warning message: '1 wire feeder(s) found, they must be configured individually.'

IV Torch setup screen showing 'Torch: CUT 2'.

V Cooler setup screen with a warning: 'Water cooling has been detected, please verify that your torch might be damaged if it supports water cooling and water cooling is disabled.'

VI Setup completed screen with a message: 'Setup completed. You can run the setup again from the machine setup menu.'

Vergrendelfunctie /

I Machine setup screen showing 'Lock level' settings.

II Lock level screen showing 'Level 1' selected.

III Functions locked screen showing 'Level 1 /' selected.

The bottom two rows of the section contain diagrams of the physical lock mechanism on a machine. The first row shows the lock in the 'unlocked' state (lock icon with an open padlock) and the second row shows it in the 'locked' state (lock icon with a closed padlock).

GRAPHICAL - Speciale functies

Software / Licenties

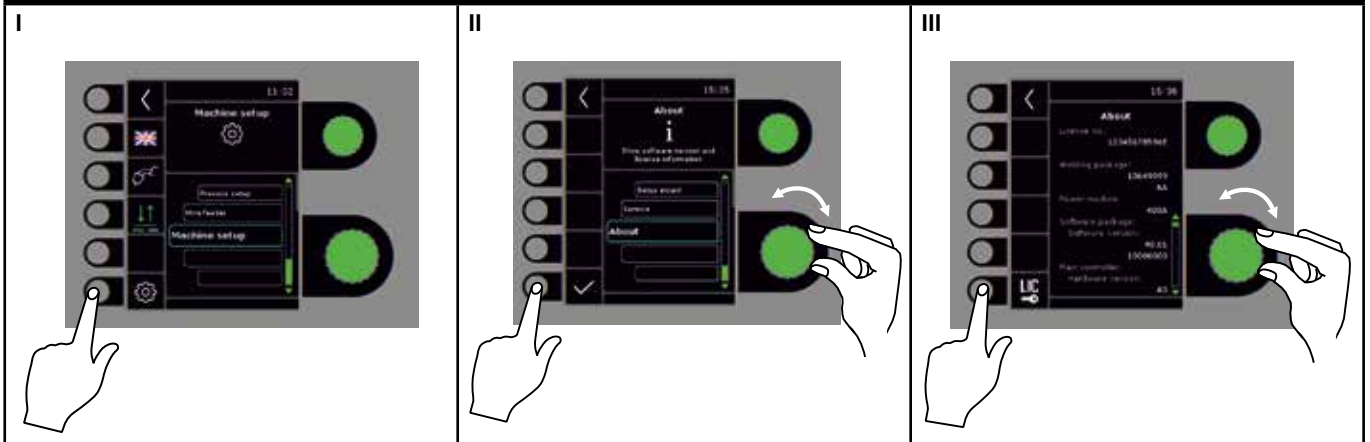

Kabellengte compensatie (kalibratie van de weerstand van het stroomcircuit)

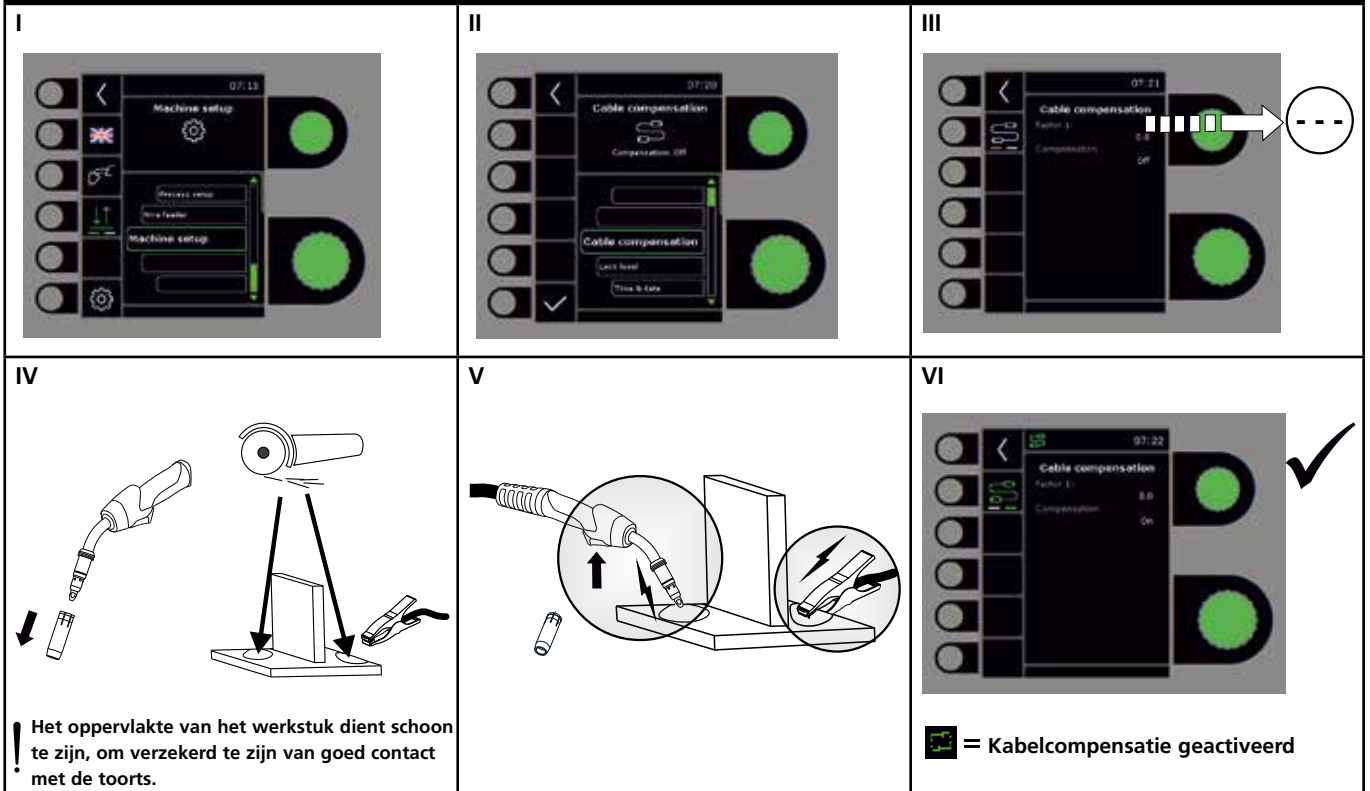

Toortsinstelling

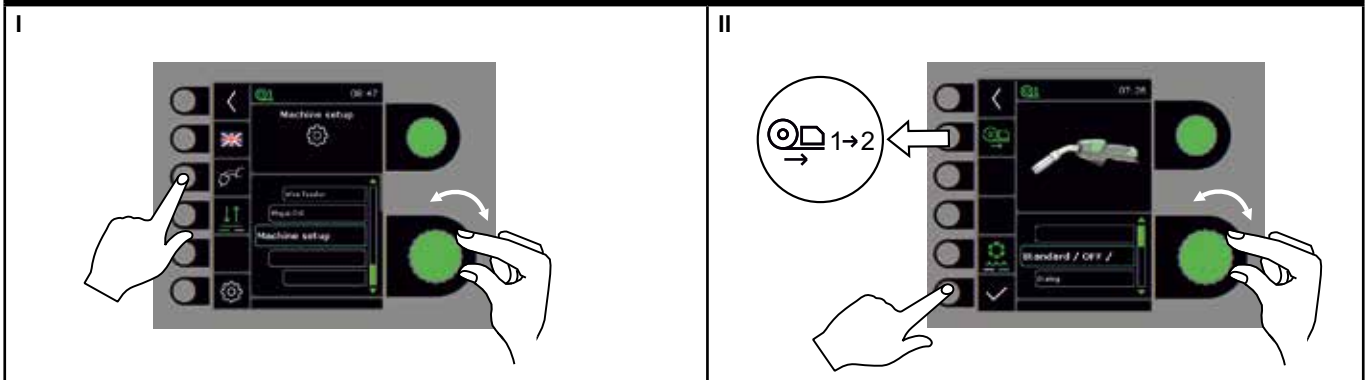

GRAPHICAL - Speciale functies

Kalibratie van gasflow (niet alle modellen)

I

II

III

IV

$10 \frac{L}{min} = 10 \frac{L}{min}$
 $20 \frac{L}{min} = 20 \frac{L}{min}$

V

GRAPHICAL - Omgaan met fouten

SIGMA Select heeft een ingebouwd geavanceerd zelfbeschermingssysteem. De machine stopt automatisch de gastoevoer, onderbreekt de lasstroom en stopt de draadaanvoer in geval van een foutmelding.

Geselecteerde fouten:

Toortskoelfout

Koelfoutindicator licht op door verkeerde aansluiting of een verstopping er geen circulatie van het koelvloeistof plaatsvindt. Controleer of de koelsslangen juist zijn aangesloten, voldoende koelvloeistof aanwezig is, en controleer de lastoorts of aanverwante slangen.



Als de koelvloeistof viscositeit wordt gereduceerd door lage temperaturen, moet de Migatronic standaard koelvloeistof worden vervangen door 99290515 BTC-20 NF koelvloeistof, die wordt gekenmerkt door zijn extreem lage geleidbaarheid en hoge viscositeit tot temperaturen van -17°C . Spoel het koelsysteem goed door voordat er een nieuwe type koelvloeistof wordt toegevoegd.

De koelfout wordt opgeheven door kort de ✓-knop in te drukken.

Gasstoring (IGC)

Een gasfout is te wijten aan een te lage of te hoge gasflow. Overtuig u ervan dat de druk op de gasflow hoger is dan 2 bar en minder dan 6 bar, want overeenkomt met resp. 5 l/min en 27 l/min. Deze foutmelding wordt uitgeschakeld door de handmatige gasflow af te stellen op 27 l/min. De gasfout wordt gereset door kort op het ✓-knop te drukken.

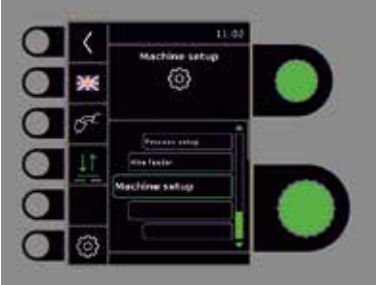
Let op: Het is belangrijk dat de ingestelde gastoevoer tijdens het lassen blijft gehandhaafd.

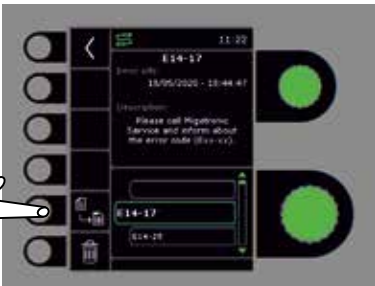
Foutenlog		
<p>I</p>  Screenshot of the 'Machine setup' menu. The screen shows 'Machine setup' at the top, with a back arrow on the left and a green indicator light on the right. Below the title, there are three menu items: 'Process setup', 'Wire feeder', and 'Machine setup'. The 'Machine setup' item is highlighted with a green bar.	<p>II</p>  Screenshot of the 'Service' menu. The screen shows 'Service' at the top, with a back arrow on the left and a green indicator light on the right. Below the title, there are three menu items: 'Error code', 'Error record', and 'Service'. The 'Service' item is highlighted with a green bar.	<p>III</p>  Screenshot of the 'Error log' menu. The screen shows 'Error log' at the top, with a back arrow on the left and a green indicator light on the right. Below the title, there is a warning icon and the text 'Error log: 29'. Below this, there are three menu items: 'Error log', 'Power module', and 'Wire feeder'. The 'Error log' item is highlighted with a green bar.
<p>IV</p> <p>Foutenlog Alle fouten worden in de foutenlog van de machine in het menu Service opgeslagen. De foutenlog kan worden gedistribueerd door een SD-kaart te plaatsen en op het volgende keypad te drukken: De foutenlog is nu op de SD-kaart opgeslagen. De foutenlog kan worden gereset door op het keypad met de vuilnisbak te drukken.</p>  Screenshot of the 'Error log' details screen. The screen shows 'Error log' at the top, with a back arrow on the left and a green indicator light on the right. Below the title, there is an error code 'E 14-17' and a date '15/05/2025 - 15:44:47'. Below this, there is a message: 'Please call Migatronic Service and inform about the error code (E14-17)'. Below the message, there are three menu items: 'Error log', 'Power module', and 'Wire feeder'. The 'Error log' item is highlighted with a green bar. A hand icon is pointing to the keypad button corresponding to the 'Error log' menu item.		

Technische gegevens 1

STROOMBON SIGMA Select	300		300 IAC		400		400 IAC		550	
Aansluitspanning $\pm 15\%$ (50-60Hz), V	3x400		3x400		3x400		3x400		3x400	
Minimale capaciteit aggregaat, kVA	16		19		27		29		40	
¹ Minimaal kortsluitvermogen Ssc, MVA	3,7		4,3		6,0		6,0		9,5	
Netzekering, A	16		16		20		20		35	
Netstroom effectief, A	11,0		16,0		17,5		16,5		27,2	
Netstroom max., A	15,4		18,3		26,0		28,2		39,2	
Opgenomen vermogen, (100%), kVA	9,0		11,1		12,1		11,4		18,9	
Opgenomen vermogen, max., kVA	10,7		12,7		18,0		19,5		27,1	
Vermogen open spanning, W	11		13		12		13		12	
Rendement, %	87		85		89		85		90	
Stroomfactor	0,90		0,90		0,90		0,90		0,90	
	MIG	MMA	MIG	MMA	MIG	MMA	MIG	MMA	MIG	MMA
Stroombereik, A	15-300	15-250	15-300	15-300	15-400	15-400	15-400	15-400	15-550	15-550
100% inschakelduur 20°C, A	290/28,5	250/30,0	300/29,0	300/32,0	345/31,5	345/33,8	310/29,5	310/32,5	475/37,8	475/39,0
Max. inschakelduur 20°C, A/%V					400/65/34,0	400/65/36,0	400/60/34,0	400/60/36,0	550/60/41,5	550/60/42,0
100% inschakelduur 40°C, A/V	220/25,0	220/28,8	270/27,5	270/30,8	300/29,0	300/32,0	280/28,0	280/31,2	430/35,5	430/37,2
60% inschakelduur 40°C, A/V	240/26,0	230/29,2			370/32,5	370/34,8	350/31,5	350/34,0	510/39,5	510/40,4
Max. inschakelduur 40°C, A/%V	300/25/29,0	250/40/30,0	300/80/29,0	300/80/32,0	400/50/34,0	400/45/36,0	400/40/34,0	400/40/36,0	550/50/41,5	550/50/42,0
Open spanning, V	50-60		65-70		65-70		65-70		75-80	
² Gebruikersklasse, C // S	S/CE // S/CE		S/CE // S/CE		S/CE // S/CE		S/CE // S/CE		S/CE // S/CE	
³ Beschermingsklasse	IP23S		IP23		IP23		IP23		IP23	
Norm, C	IEC60974-1, IEC60974-5, IEC60974-10 Cl. A									
Norm, S	IEC60974-1, IEC60974-10 Cl. A									
Afmetingen C (HxBxL), mm	700x260x735		700x260x735		700x260x735		700x260x735		700x260x735	
Afmetingen S (HxBxL), mm	454x260x735		454x260x735		454x260x735		454x260x735		454x260x735	
Gewicht C / S, kg	36,9 / 26		53 / 36		52 / 35		53 / 36		53 / 36	

STROOMBON SIGMA Select	300 Boost				300 IAC Boost			
Aansluitspanning $\pm 10\%$ (50-60Hz), V	3x208-380				3x380-440			
Minimale capaciteit aggregaat, kVA	16				25			
¹ Minimaal kortsluitvermogen Ssc, MVA	1,7				3,75			
Netzekering, A	20				16			
Netstroom effectief, A	19,5				10,6			
Netstroom max., A	31,6				16,2			
Opgenomen vermogen, (100%), kVA	7,1				7,0			
Opgenomen vermogen, max., kVA	11,0				10,6			
Vermogen open spanning, W	45				16			
Rendement, %	82				87			
Stroomfactor	0,95				0,95			
	MIG	MMA	MIG	MMA	MIG	MMA	MIG	MMA
Stroombereik, A	15-300	15-250	15-300	15-250	15-300	15-300	15-300	15-300
100% inschakelduur 20°C, A	250/26,5		250/26,5		300/29,0	300/32,0	300/29,0	300/32,0
Max. inschakelduur 20°C, A/%V	300/40/29,0		300/40/29,0					
100% inschakelduur 40°C, A/V	200/24,0	200/28,0	200/24,0	200/28,0	250/26,5	220/28,8	250/26,5	220/28,8
60% inschakelduur 40°C, A/V	210/24,5	210/28,4	210/24,5	210/28,4	270/27,5	250/30,0	270/27,5	250/30,0
Max. inschakelduur 40°C, A/%V	300/25/29,0	250/35/30,0	300/25/29,0	250/35/30,0	300/35/29,0	300/30/32,0	300/35/29,0	300/30/32,0
Open spanning, V	50-60				70-75			
² Gebruikersklasse, C // S	S/CE // S/CE				S/CE // S/CE			
³ Beschermingsklasse	IP23S				IP23			
Norm, C	IEC60974-1, IEC60974-5, IEC60974-10 Cl. A							
Norm, S	IEC60974-1, IEC60974-10 Cl. A							
Afmetingen C (HxBxL), mm	700x260x735				900x260x735			
Afmetingen S (HxBxL), mm	454x260x735				654x260x735			
Gewicht C / S, kg	45 / 34				66 / 49			

- Deze apparatuur voldoet aan EN / IEC61000-3-12:2014 (/ 2011) op voorwaarde dat het kortsluitvermogen Ssc van de voeding bij het aansluitpunt groter is of gelijk is aan de gegevens zoals in bovenstaande tabel bevestigd is. Het is de verantwoordelijkheid van de installateur of de gebruiker van de installatie, om zich ervan te overtuigen, dat de apparatuur uitsluitend aangesloten is op een voeding met een kortsluitvermogen Ssc groter is of gelijk is aan de gegevens zoals in bovenstaande tabel bevestigd is. Indien nodig kan een nagegaan bij de energieleverancier
- Deze machine voldoet aan de eisen gesteld aan machines die moeten werken in gebieden waar een verhoogd risico bestaat voor elektrische schokken
- De machine is ontworpen voor gebruik binnen en buiten volgens beschermingsklasse IP23/IP23S.
IP23S: De machine mag worden opgeslagen, maar is niet bedoeld om tijdens neerslag buiten te worden gebruikt, tenzij onder een beschutting

Technische gegevens 2

STROOMBRON SIGMA Select	400 Boost				400 IAC Boost			
Aansluitspanning $\pm 10\%$ (50-60Hz), V	3x208-380		3x380-440		3x208-380		3x380-440	
Minimale capaciteit aggregaat, kVA	25		25		25		25	
¹⁾ Minimaal kortsluitvermogen Ssc, MVA					4,0		4,0	
Netzekering, A	25-50		25-50		25-50		25-50	
Netstroom effectief, A	22,0		11,7		24,8		11,8	
Netstroom max., A	45,0		23,5		48,0		24,5	
Opgenomen vermogen, (100%), kVA	8,3		8,1		8,5		8,5	
Opgenomen vermogen, max., kVA	16,7		16,3		17,4		17,4	
Vermogen open spanning, W	60		56		60		71	
Rendement, %	84		88		82		85	
Stroomfactor	0,96		0,95		0,96		0,96	
	MIG	MMA	MIG	MMA	MIG	MMA	MIG	MMA
Stroombereik, A	15-400	15-400	15-400	15-400	15-400	15-400	15-400	15-400
100% inschakelduur 20°C, A	300/29,0	300/32,0	300/29,0	300/32,0	300/29,0	300/32,0	300/29,0	300/32,0
Max. inschakelduur 20°C, A/%V	400/30/34,0	400/30/32,0	400/30/34,0	400/30/32,0	400/30/34,0	400/30/32,0	400/30/34,0	400/30/32,0
100% inschakelduur 40°C, A/V	250/26,5	220/28,8	250/26,5	220/28,8	250/26,5	220/28,8	250/26,5	220/28,8
60% inschakelduur 40°C, A/V	280/28,0	260/30,4	280/28,0	260/30,4	280/28,0	260/30,4	280/28,0	260/30,4
Max. inschakelduur 40°C, A/%V	400/25/34,0	400/20/36,0	400/25/34,0	400/20/36,0	400/25/34,0	400/20/36,0	400/25/34,0	400/20/36,0
Open spanning, V	70-75				70-75			
²⁾ Gebruikersklasse, C // S	S/CE // S/CE				S/CE // S/CE			
³⁾ Beschermingsklasse	IP23				IP23			
Norm, C	IEC60974-1, IEC60974-5, IEC60974-10 Cl. A				IEC60974-1, IEC60974-5, IEC60974-10 Cl. A			
Norm, S	IEC60974-1, IEC60974-10 Cl. A				IEC60974-1, IEC60974-10 Cl. A			
Afmetingen C (HxBxL), mm	900x260x735				900x260x735			
Afmetingen S (HxBxL), mm	654x260x735				654x260x735			
Gewicht C / S, kg	66 / 49				67 / 50			

DRAADTOEVOERKOFFER MWF			
Draadtoevoersnelheid, m/min	0,5-30,0		
Toortsaansluiting	EURO		
Diameter draadhaspel, mm	300		
Draadhaspel, kg	5-18		
100% inschakelduur 40°C, A/%	430		
60% inschakelduur 40°C, A/%	500		
Max. inschakelduur 40°C A/%	550/50		
³⁾ Beschermingsklasse	IP23		
Draaddiameter, mm	0,6-1,6		
Gasdruk, MPa (bar)	0,6 (6,0)		
	MWF 30	MWF 32	MWF 33
Afmetingen (HxBxL), mm	413x310x750	457x260x672,5	457x260x672,5
Gewicht, kg	11,6	14,0	14,0
Norm	IEC60974-5, IEC60974-10 Cl. A		

KOELUNIT MCU 1300	
Koelvermogen (1 l/min), W	1300
Koelvermogen (1,5 l/min), W	1600
Inhoud tank, liter	5
Waterdoorstroom, bar - °C - l/min	3,0-60-1,5
Maximale druk, bar	5
Norm	IEC60974-2, IEC60974-10 CL.A
Afmetingen (HxBxL), mm	207x260x680
Gewicht	20

VERKLARING VAN OVEREENSTEMMING

CE

MIGATRONIC A/S
Aggersundvej 33
9690 Fjerritslev
Denmark

Verklaart dat onderstaande machine
Type: SIGMA Select
voldoet aan richtlijn: 2014/35/EU
2014/30/EU
2011/65/EU

Europese standaarden: EN IEC60974-1:2018/A1:2019
EN IEC60974-2:2019
EN IEC60974-5:2019
EN / IEC60974-10:2014/A1:2015

Regelgeving: 2019/1784/EU

Fjerritslev 10.02.2021

Kristian M. Madsen
Kristian M. Madsen
CEO

- Deze apparatuur voldoet aan EN / IEC61000-3-12:2014 (/ 2011) op voorwaarde dat het kortsluitvermogen Ssc van de voeding bij het aansluitpunt groter is of gelijk is aan de gegevens zoals in bovenstaande tabel bevestigd is. Het is de verantwoordelijkheid van de installateur of de gebruiker van de installatie, om zich ervan te overtuigen, dat de apparatuur uitsluitend aangesloten is op een voeding met een kortsluitvermogen Ssc groter is of gelijk is aan de gegevens zoals in bovenstaande tabel bevestigd is. Indien nodig kan een nagegaan bij de energieleverancier
- Deze machine voldoet aan de eisen gesteld aan machines die moeten werken in gebieden waar een verhoogd risico bestaat voor elektrische schokken
- De machine is ontworpen voor gebruik binnen en buiten volgens beschermingsklasse IP23/IP23S.
IP23S: De machine mag worden opgeslagen, maar is niet bedoeld om tijdens neerslag buiten te worden gebruikt, tenzij onder een beschutting

KytKentä ja käyttö

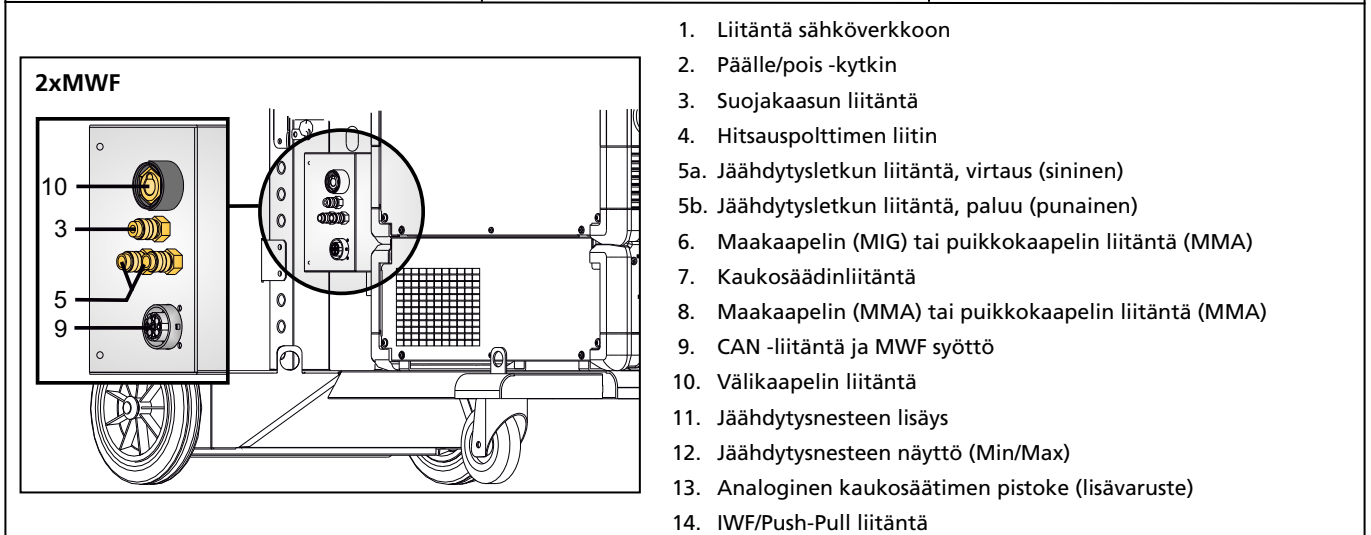
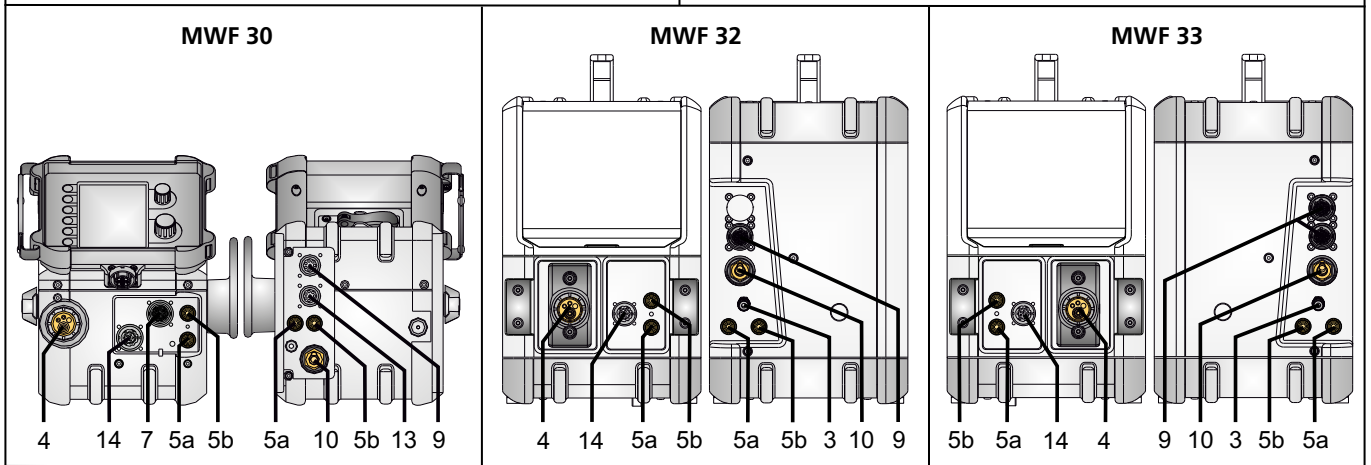
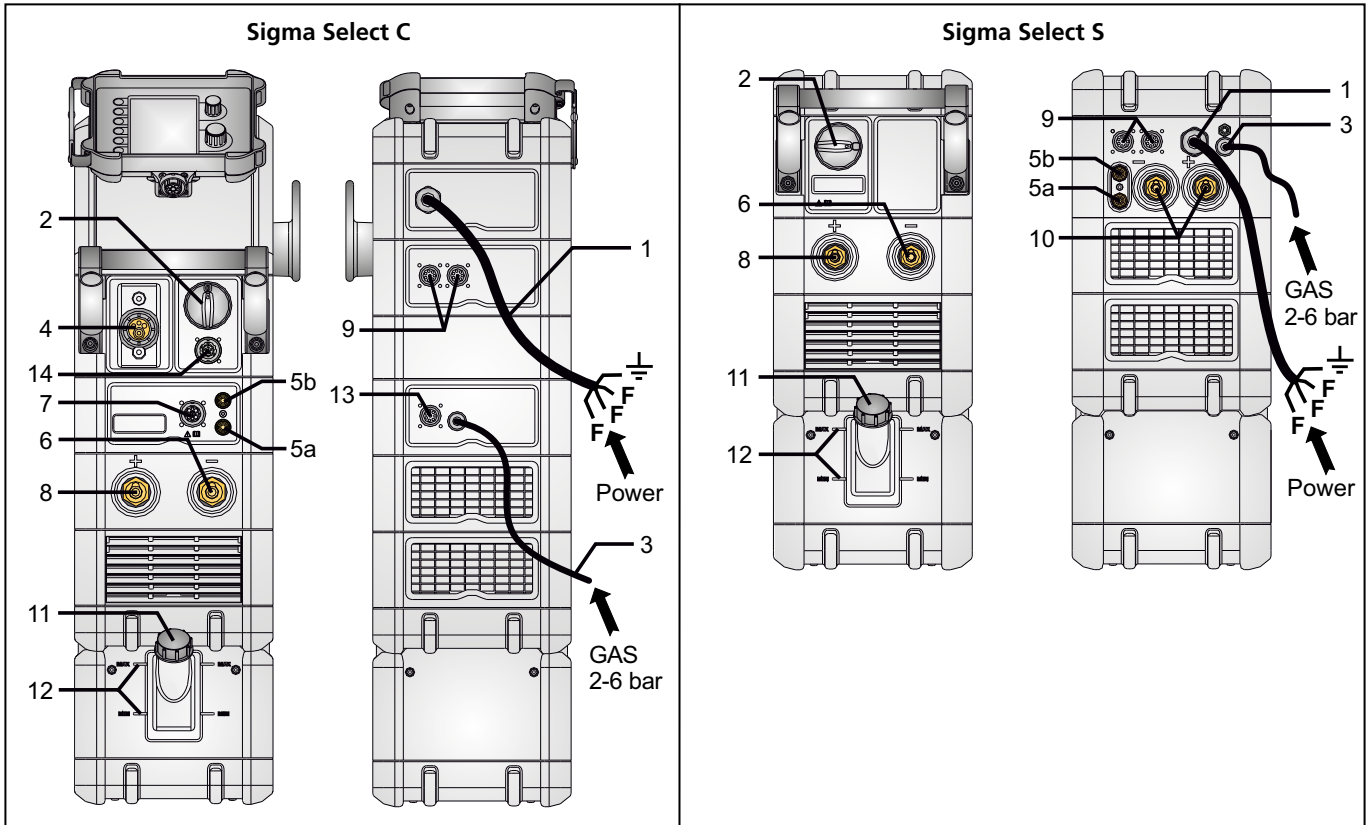

KytKentä ja käyttö



Varoitus

Lue huolellisesti nämä varoitukset sekä käyttöohje, ennen kuin otat koneen käyttöön. Säilytä käyttöohje myöhempiä käyttöä varten.

Luvallinen asennus

Liitäntä sähköverkkoon

Tarkista koneen takaa arvokilvestä, mikä on oikea verkkojännite.

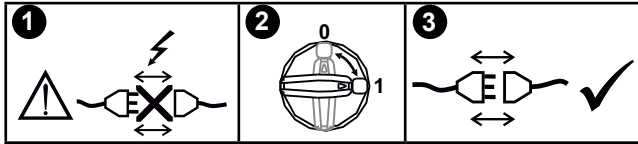
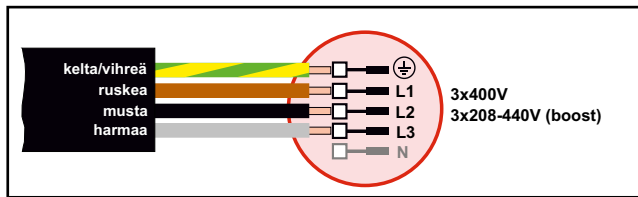

Jännitteen vakauttamissarja

Virtalähde on konfiguroitavissa jännitteen vakautussarjalla, suojana suuremmilta jännitteen vaihteluilta, esim. Generaattorikäytössä, jossa hitsauskone on kytketty erilliseen virtalähteeseen.

Suojakaasun liitäntä

Virtalähteen takapaneelista lähtevä suojakaasuletku (3) liitetään kaasunlähteeseen paine laskettuna 2-6 bariin. (Huomaa: Jotkin paineensäädintyypit vaativat yli 2 barin ulostulopaineen toimiakseen optimaalisesti). Kaasupullo/kaasupullot pitää asentaa koneen taakse kaasupulloalustalle sidottuna siellä olevilla liinoilla.

Kaasun kulutus

Hitsaustehtävistä, kaasutyypistä ja hitsauman rakenteesta riippuen kaasunkulutus vaihtelee välillä 6-7 l/min pienillä hitsausvirroilla (<25A) ja jopa 27 l/min max. hitsausvirroilla.

Materiaalin kulutus

Materiaalinkulutus voidaan arvioida laskemalla hitsausaika minuuteissa kertaa langansyöttönopeus (m / min) kertaa käytetyn hitsauslisäaineen paino / metri.

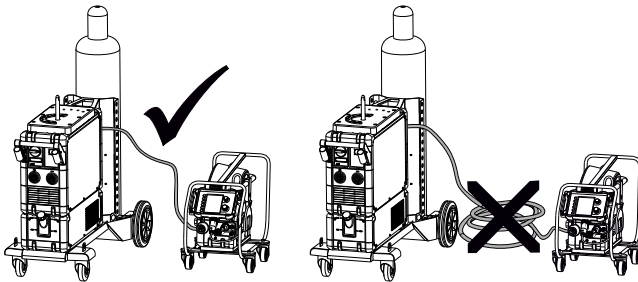

VAROITUS

Hitsauslanka/elektrodi on jännitteellinen, kun polttimen liipaisimesta painetaan.

Hitsauspolttimen asennus

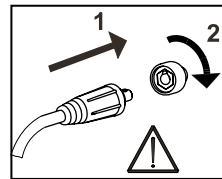
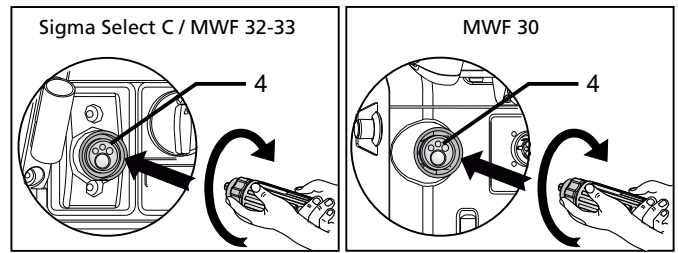

Tärkeää!

Kiinnitä huolellisesti maakaapeli ja hitsauspolttin. Liittimet ja kaapeli voivat muuten vaurioitua.

Puikontipin kytkentä puikkohitsausta varten

Puikontipidin ja paluuvirtakaapeli kytketään plusliittimeen (10) ja miinusliittimeen (8). Noudata hitsauspuikkovalmistajan ohjeita valitessasi napaisuutta.

Suosittelut kaapeleiden mitat

Hitsausvirta	DC	PULSSI
200 A	35 mm ²	35 mm ²
300 A	50 mm ²	70 mm ²
400 A	95 mm ² / 2x50 mm ²	95 mm ² / 2x50 mm ²
550 A	2x70 mm ²	2x70 mm ²

Hitsausprosessi	Etäisyys työkappaleeseen (a+b)	Kaapeleiden kokonaispituus hitsauspiirissä (a+b+c)
MIG - IAC ja pulssi	10 m	20 m
MIG - ilman pulssia	30 m	60 m

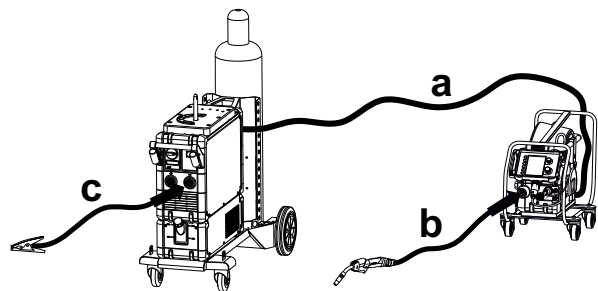

Lankajarrun säätö

Jarru pitää säätää niin lujaa, että lankakela pysähtyy, ennen kuin lanka tulee kelan yli ja sotkeutuu. Jarrun kireys riippuu lankakelan painosta ja lankanopeudesta.

Tehdasasetus = 15 kg.

Säätö:

- Irrota säätönappi asettamalla ohut ruuvimeisseli nupin taakse, minkä jälkeen voit vetää sen pois.
- Säädä jarru kiristämällä tai löysäämällä lankakelan napakselin itselukitsevaa mutteria.
- Nappi pitää jälleen asentaa paikoilleen.

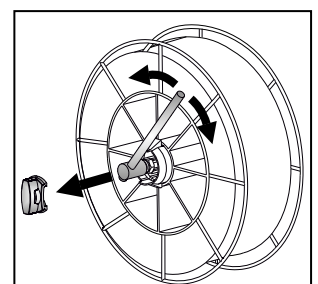

Kytcentä ja käyttö

Nosto-ohjeet

Konetta tai MWF-langansyöttölaitetta nostettaessa on ehdottomasti käytettävä alla olevan kuvan mukaisia nostopisteitä. Konetta ei saa nostaa kaasupullon ollessa kytkettynä laitteeseen.

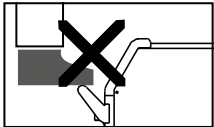
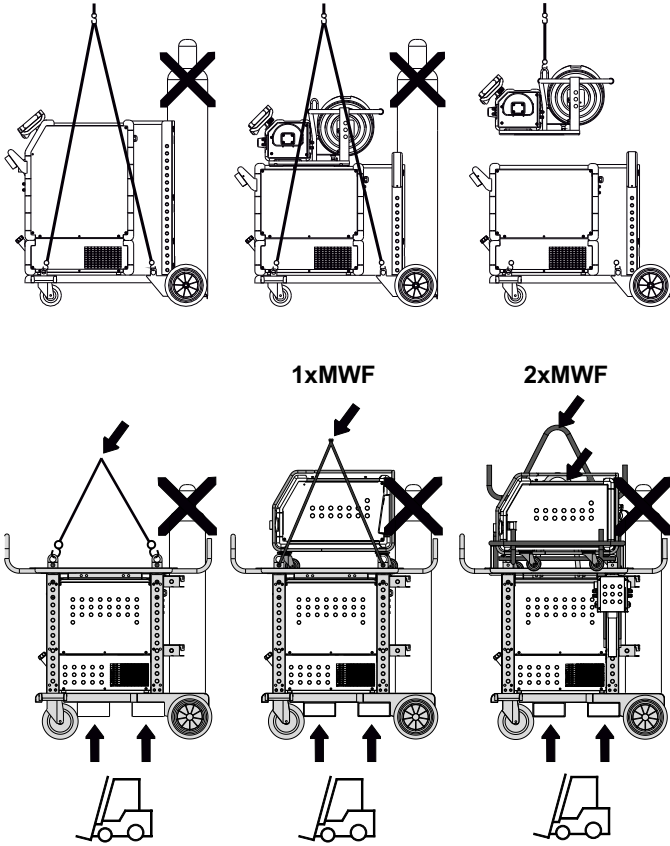

Älä nosta hitsauskonetta kädensijasta.
Älä astu kädensijan päälle.

Kauko-ohjaimen asennus

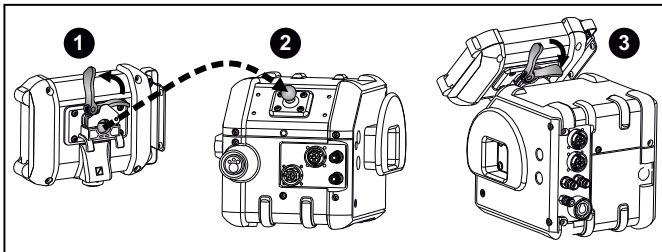

MWF 30 kaapelin kelaus

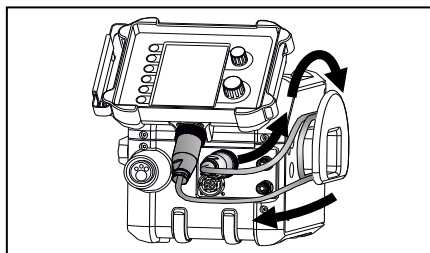

MCU vedenkiertolaitteen ilmaus

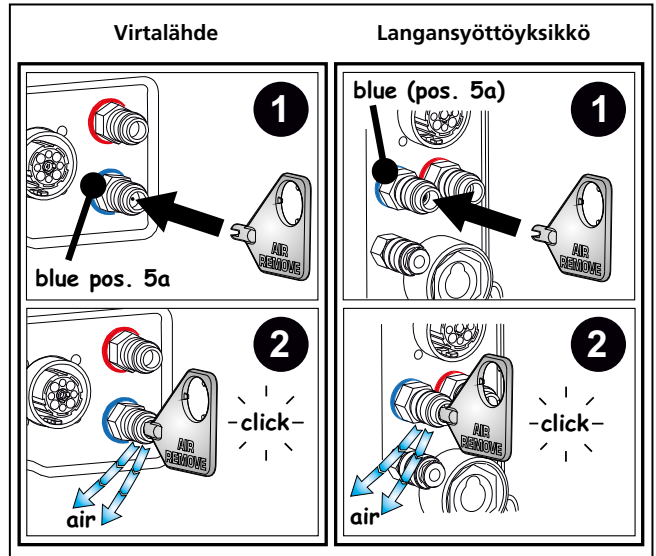

MWF käännön lukitustoiminto

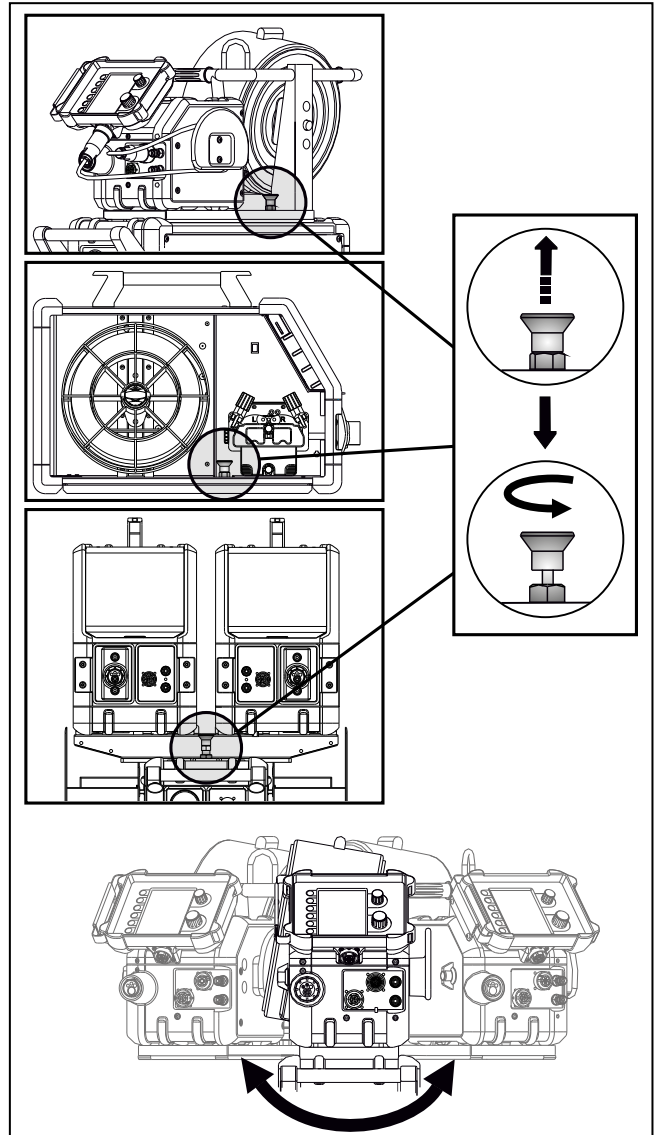

KytKentä ja käyttö

OsiEn asennus langansyöttölaiteeseen

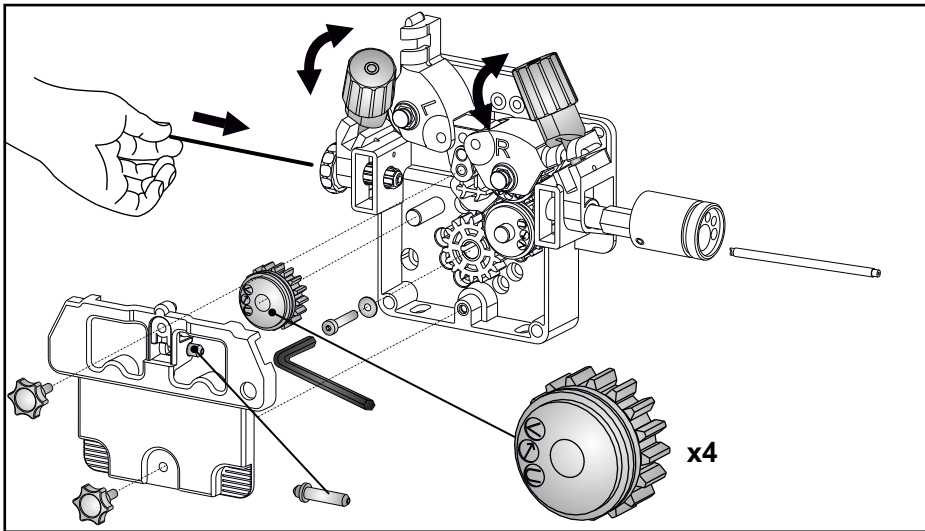

Säädä syöttöpyörien paine siten, että se juuri ja juuri liukuu langan päällä, kun tämä pysäytetään kontaktisuuttimen kohdalla

Langansyöttäminen eteenpäin/taaksepäin

Joutokäynnin aikana langansyöttö voidaan aktivoida painamalla yhtä näppäimistä tai aktivoida robottiliitännällä, jos MWF30-yksikköä käytetään robottiasetuksissa.

Langansyöttäminen

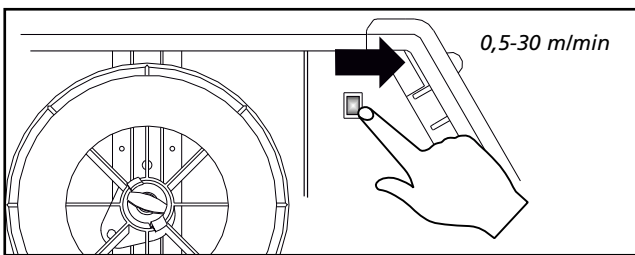

Langansyöttäminen MWF 30

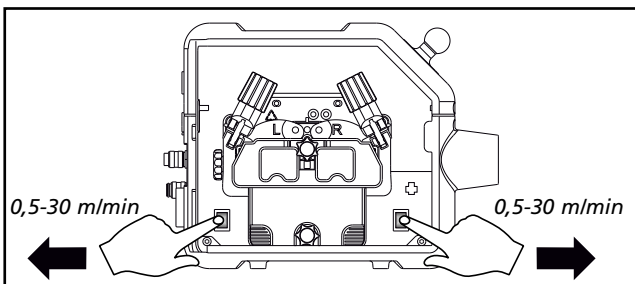

Langansyöttäminen Graphical

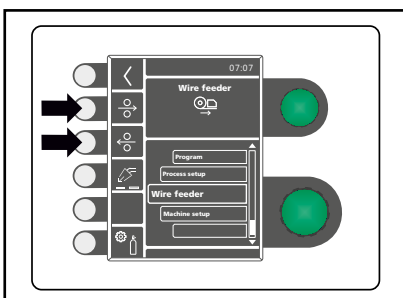

Ohjelman päivittäminen

- Aseta SD-kortti.
- Kone käynnistetään tämän jälkeen.
- Odota, kunnes yksikkö ilmoittaa, että päivitys on valmis.
- Kone pitää jälleen sammuttaa kytkimestä ja SD-kortti poistaa.
- Kone on käyttövalmis.

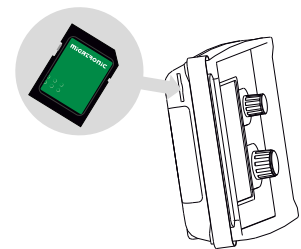

Uusi ohjelmisto ladataan virtalähteeseen ja kaikkiin liitettyihin laitteisiin.

Ohjelman voi ladata myös <http://migatronic.com> SD-kortille. SD-kortin tiedostojärjestelmä on alustettava FAT32-muotoon.

TÄRKEÄ:

Tallenna ohjelmisto //MIGA_SW/SIGMA/ tiedostorakenteeseen.

Lisenssi SW

Jos ostetaan useita lisenssejä tai erikoistoimintoja, mitkä on MigALic.dat ohjelmaan ladattu, on hyvä ottaa niistä varmuuskopiot.

MigALic.txt sisältää tietoja, koneen lisenssinumeron ja ne on tallennettu SD-kortille.

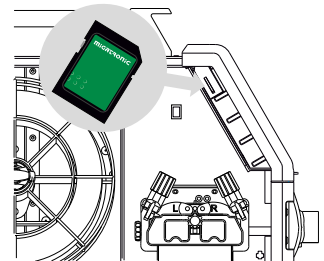

BASIC - Erikoistoiminnot

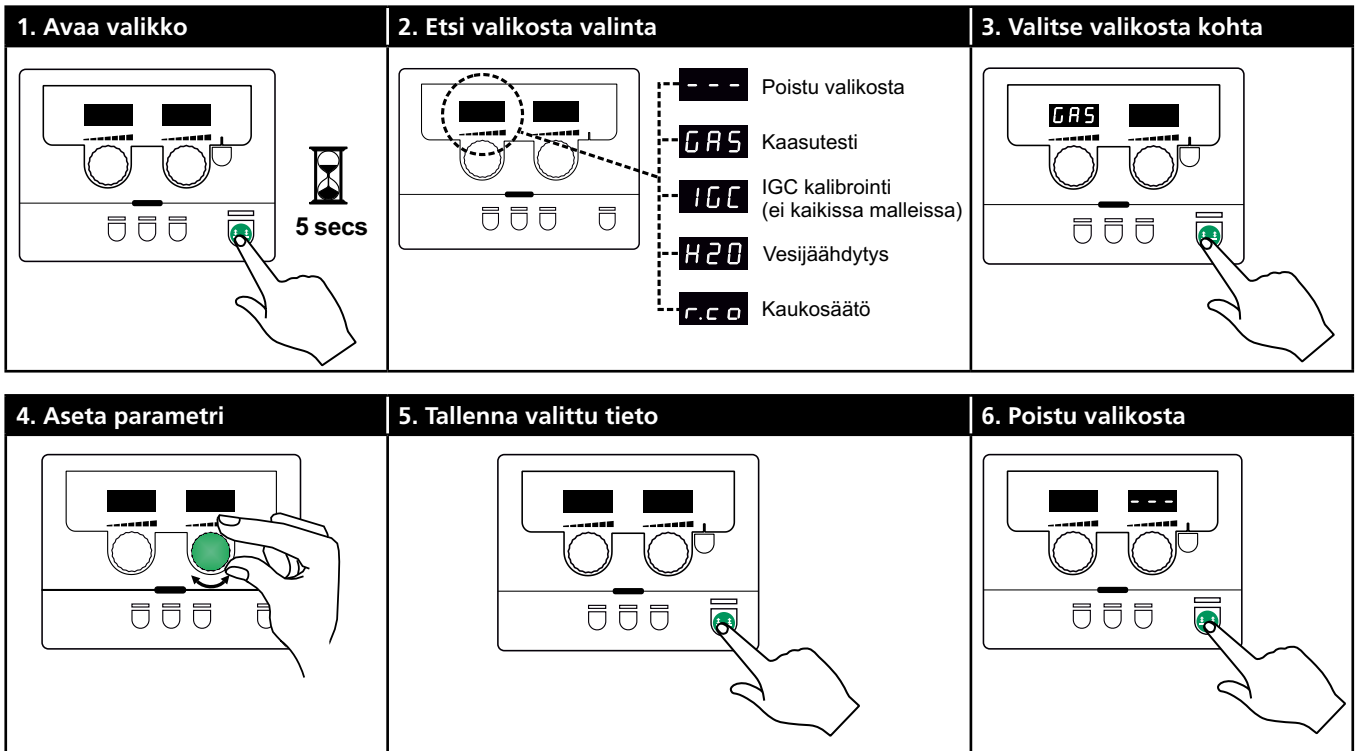

Parametrien ja valikon valinta

Paina ja pidä painettuna -näppäin avataksesi käyttäjävalikon. Käännä vasemmanpuoleista vääntönuppia, kunnes haluttu valikko näkyy näytössä. Käytä oikeanpuoleista vääntönuppia muuttaaksesi asetuksia oikealla näytöllä. Paina -näppäintä lyhyesti aktivoiaksesi toiminnan, kuten kaasutestin.

Käyttäjälavikon toiminnot ja parametrit:

--- **GAS** **IGC** **H2O** **r.c.o**

--- Paina -näppäintä poistuaksesi valikosta.

GAS Kaasutesti
Paina -näppäintä avataksesi ja sulkeaksesi kaasuventtiilin. Jos kone on varustettu IGC-ominaisuudella, on mahdollista säätää kaasunvirtausta oikeanpuoleisella vääntönupilla.

IGC IGC kalibrointi
Näkyä ainoastaan, jos IGC on asennettu.
Paina -näppäintä aloittaaksesi IGC:n kalibroinnin.

H2O Vesijäähdytys
Näkyä vain, jos vesijäähdytysyksikkö on asennettu.

0: Vesijäähdytys POIS

1: Vesijäähdytys PÄÄLLÄ

r.c.o Kaukosäätimen asetus

Käytä oikeanpuoleista vääntönuppia vaihtaaksesi seuraavia asetuksia:

0: Pois käytöstä

1: Dialog-poltin (tuotenumero 80100402)

2: Analoginen kaukosäädin (tuotenumero 78815029)

BASIC - Erikoistoiminnot

Kaukosäätimen asetus

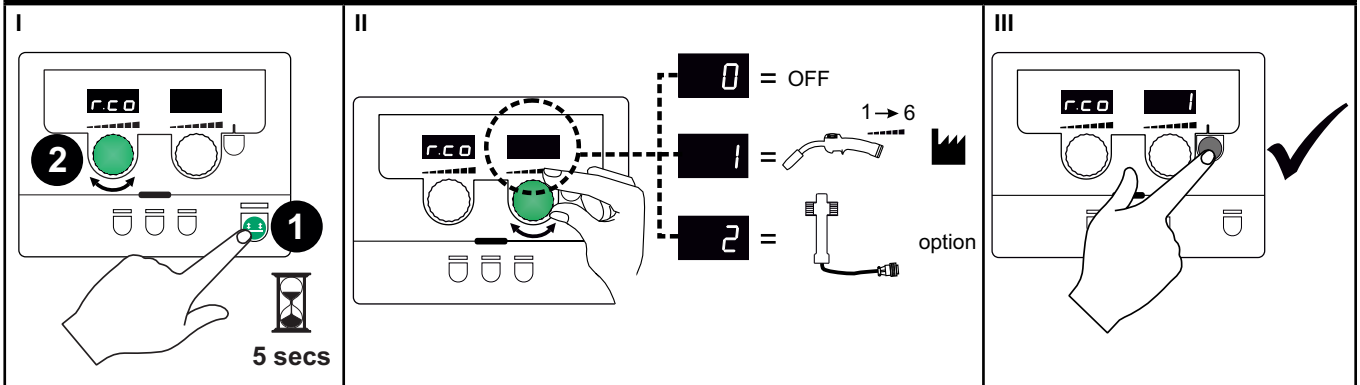

Sulkutoiminto /

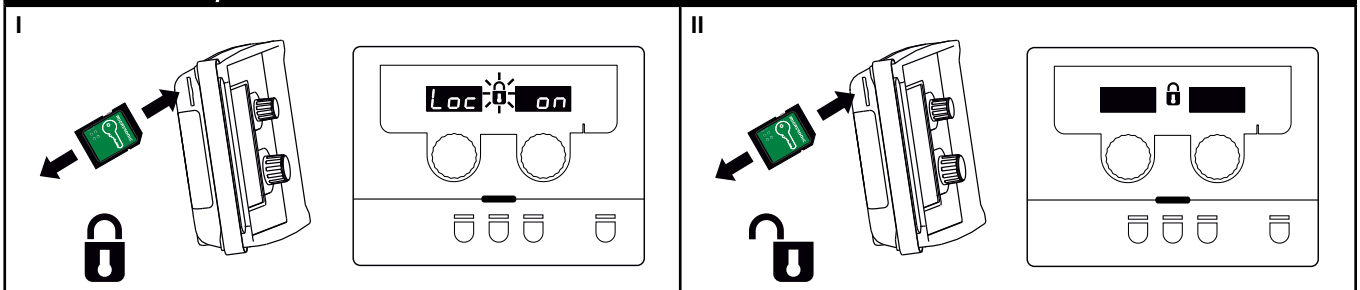

Kaasuvirtauksen kalibrointi (ei kaikissa malleissa)

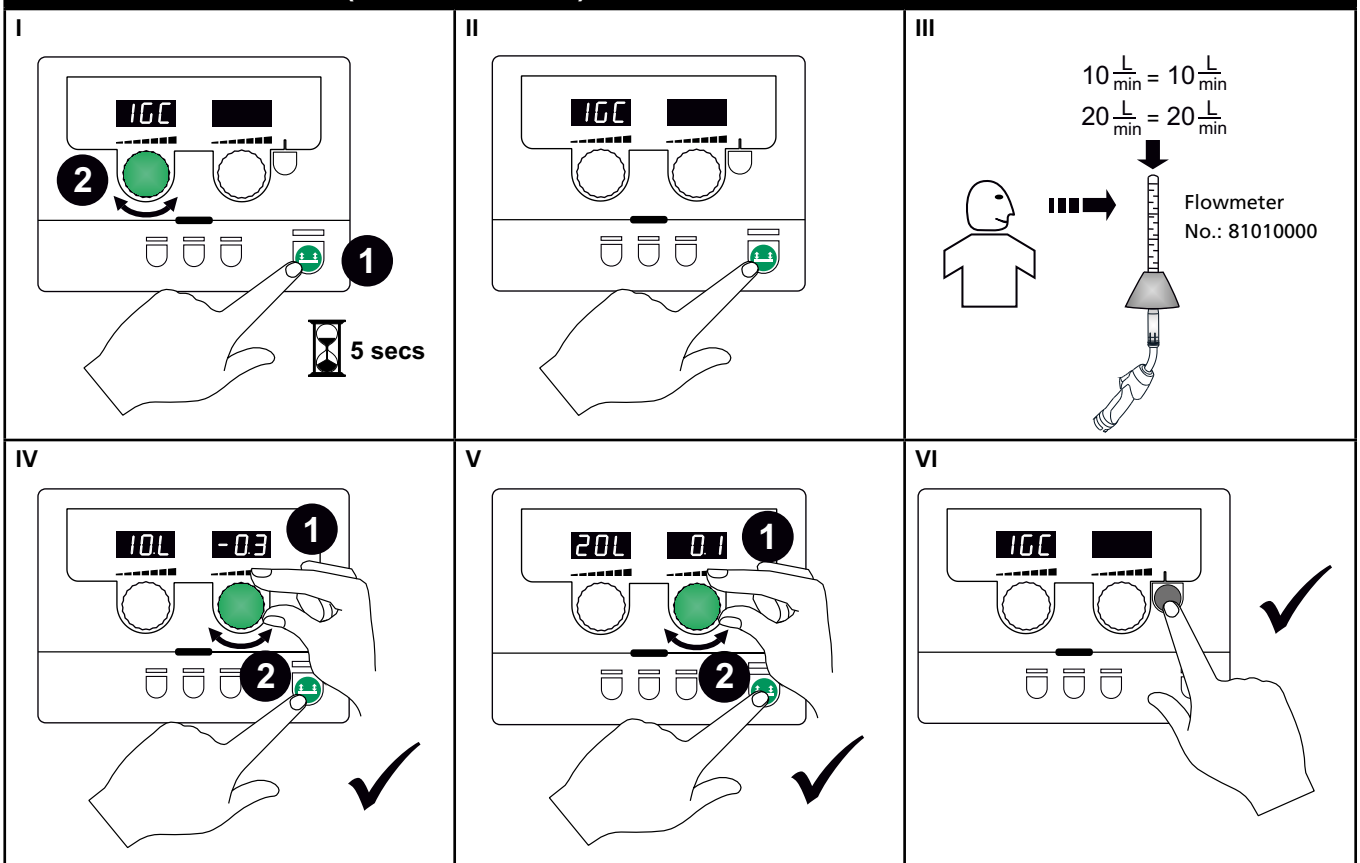

BASIC - Erikoistoiminnot

Ohjelmaversiön näyttö/Lisenssi numero

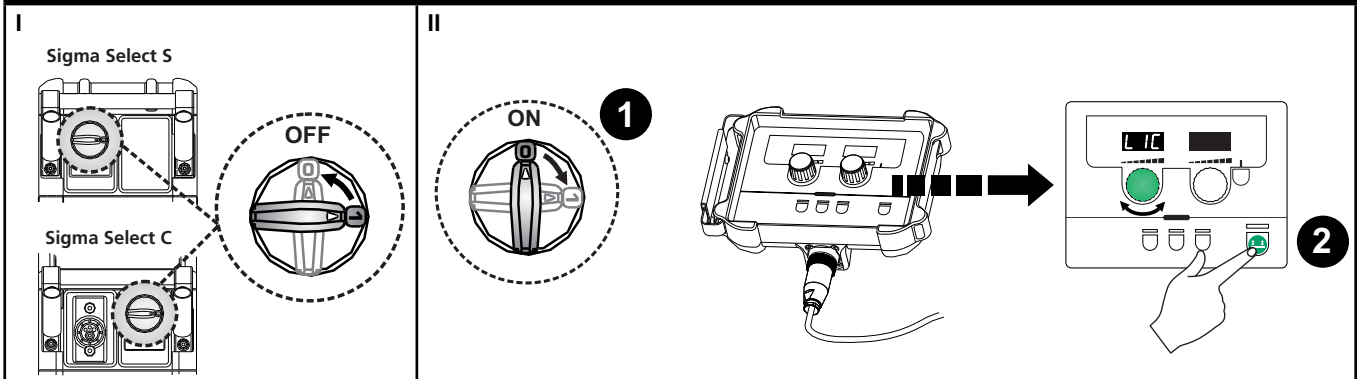

1. Lisenssinumero

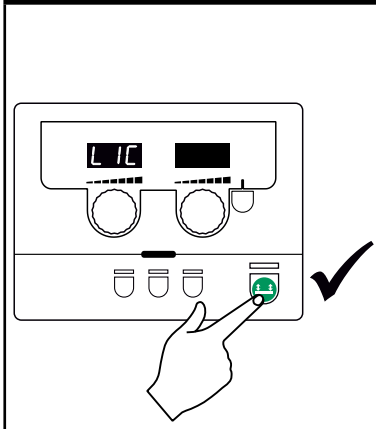

2. Katso lisenssinumero (12 merkkiä)

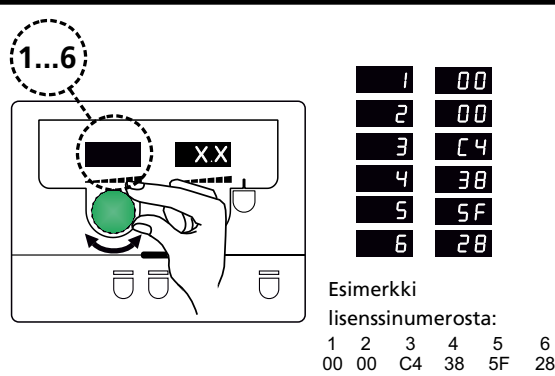

3. Palaa SW versioihin

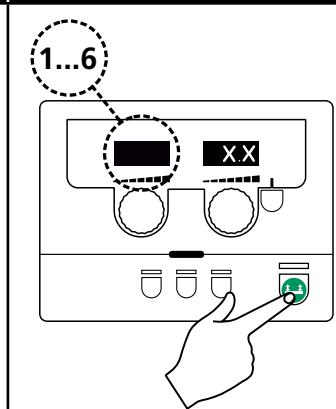

4. Valitse SW

Basic remote	1
Welding package	2
Main controller	3
"..."	4
"..."	5
Wire feeder	6
Wire feeder	7
Arc controller	8
"..."	9
"..."	10
"..."	11
"..."	12
"..."	13
"..."	14
"..."	15
"..."	16
Water controller	17
Smart Torch	18

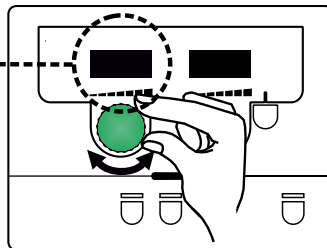

5. Poistu valikosta

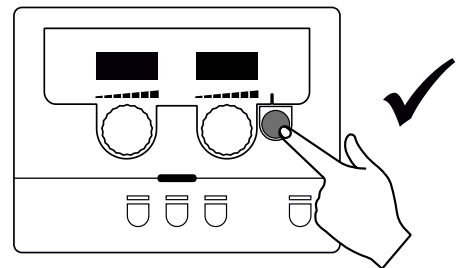

"..." ei käytössä

BASIC - Virheiden käsittely

Virhekoodi	Syy ja korjaus
E20-00 E20-02 E21-00 E21-06 E21-08	Ohjausyksikössä ei ole ohjelmaa Ohjelma tulee lukea SD-kortilta, ohjelmoitu SD-kortti tulee asettaa koneeseen ja kone käynnistää. SD-kortti pitää mahdollisesti vaihtaa.
E20-01 E21-01	SD-kortissa ei ole formaattia SD-kortin formaatti pitää tallentaa tietokoneella FAT muodossa ja ohjelma tulee lukea SD-kortilta. SD-kortti pitää mahdollisesti vaihtaa.
E20-03 E21-02	SD-kortilla on useampia ohjelmia samalla nimellä SD-kortti tulee tyhjentää ja kortti tulee uudelleen ohjelmoida ja syöttää koneeseen.
E20-04	Ohjausyksikkö yrittää lukea useimpia ohjelmia, mitä muistiin mahtuu SD-kortti pitää uudelleen tallentaa koneeseen tai SD-kortti on viallinen ja täytyy vaihtaa. Ottakaa yhteyttä Migatronin asiakaspalveluun tai keskushuoltoon, jos vika on edelleen koneessa.
E20-05 E20-06	Ohjelma SD-kortilla on tarkoitettu toiselle ohjausyksikölle SD-kortille pitää tallentaa oikea ohjelma.
E20-07	Sisäinen kopiosuoja estää sisäänkäynnin mikroprosessorille SD-kortti pitää uudelleen tallentaa koneeseen tai ottakaa yhteyttä Migatronin asiakaspalveluun tai keskushuoltoon.
E20-08 E20-09 E21-05	Ohjausyksikössä on vika Ottakaa yhteyttä Migatronin asiakaspalveluun tai keskushuoltoon.
E20-10 E21-07	Tiedosto on virheellinen SD-kortti pitää jälleen tallentaa koneeseen tai SD-kortti pitää vaihtaa.
E21-03 E21-04	Hitsausohjelmat eivät käy tämän koneen ohjausyksikköön SD-kortti pitää uudelleen ohjelmoida ja tarkistaa koneen malli oikealle ohjelmatyypille.
Err GAS	Kaasuvirhe Tarkista kaasunvirtaus. Kaasunvirtaus tulee näyttöön painamalla mitä tahansa näppäintä.
E02-04	CAN yhteysvirhe Tarkista välikaapeli ja liittimet.
E11-20	Virransyötössä vika 1. Tarkista verkkovirran syöttö/sulakkeet. 2. Ottakaa yhteyttä Migatronin asiakaspalveluun tai keskushuoltoon.

Vikasymbolit



Ylikuumeneminen

Ylikuumenemisen merkkivalo palaa mikäli hitsaustyö on keskeytynyt koneen ylikuumenemisen takia.

Pidä kone päällekytkettynä, kunnes sisäarakennettu tuuletin on sammunut.



Vika sähkövirrassa

Led-valo vilkkuu kun aloitusvirta tai hitsausvirta on korkeampi kuin hitsauskoneen suoritusarvot sallivat.

Varmista, että lankanopeus/virta-asetukset on tehty oikein.



Vikasymbolit

Merkkivalo vilkkuu, jos on ilmennyt muita vikamahdollisuuksia, esim. verkkovaihe puuttuu. Samaan aikaan näytölle ilmestyy vikasymboli.

Koneen ilmoittamat vikakoodit



Vika verkkovirrassa

Merkkivalo palaa kun verkkovirta on liian korkea.

Liitä hitsauskone 400V AC, +/- 15% 50-60Hz.



Vika hitsauspolttimen jäähdytyksessä

Virtauksenvartijalla (water flow kit) varustetussa hitsauskoneessa vikakoodi osoittaa viallisen liitännän tai letkuntukkeutumisen siinä tapauksessa, että jäähdytysneste ei pääse virtaamaan. Tarkista jäähdytysletkujen kiinnitykset ja liitännät, täytä vesisäiliö ja tarkista hitsausletku haaroineen.

Jos jäähdytysnesteen viskositeetti laskee alhaisen lämpötilan vuoksi, vakio Migatronic-jäähdytysneste on vaihdettava 99290515 BTC-20 NF jäähdytysnesteeseen, jolle on ominaista erittäin alhainen johtavuus ja korkea viskositeetti aina -17 °C:n lämpötiloihin asti. Huuhtelee jäähdytysjärjestelmä ennen uudentyyppisen jäähdytysnesteen lisäämistä.

Lyhyt painallus -näppäimellä poistaa vikakoodin.



Vika kaasunsyötössä (IGC)

Kaasunvirtaus on liian vähäinen tai liian suuri. Varmista, että kaasuvirran paine on yli 2 bar ja alle 6 bar, vastaten arvoja 5 l/min ja 27 l/min. Kaasuvirhe saadaan pois toiminnasta säätämällä kaasunvirtaus manuaalisesti arvoon 27 l/min.

Kaasunvirhe poistuu lyhyellä painalluksella -näppäimestä.

Vika langansyötössä



E01 00 tai **E01 01**

Kuvake ilmoittaa langansyöttömoottorin ylikuormituksesta.

Langansyöttömoottori tai magneettiventtiili saattaa olla viallinen.

Muita vikoja

Mikäli näytölle ilmestyy muita vikasymboleja, koneesta on sammutettava virta ja kytkettävä jälleen päälle, minkä jälkeen symboli katoaa. Mikäli vikasymboli ilmestyy yhä uudelleen, virtalähde on korjattava. Ota yhteyttä jälleenmyyjään ja kerro viasta.

Kun erilliset yksiköt on kytketty, seuraavat virhekoodit voivat tulla näytölle:



E07 04 Tulee näytölle, jos tiedonsiirto virtalähteen ja liitetyin laitteen/laitteiden väliltä häviää.



E07 05 Tulee näytölle, jos moottorihajaus ei ole kunnossa.



E07 06 Tulee näytölle, jos moottori on ylikuormitettu.

GRAPHICAL - Erikoistoiminnot

Ohjattu asennustoiminto

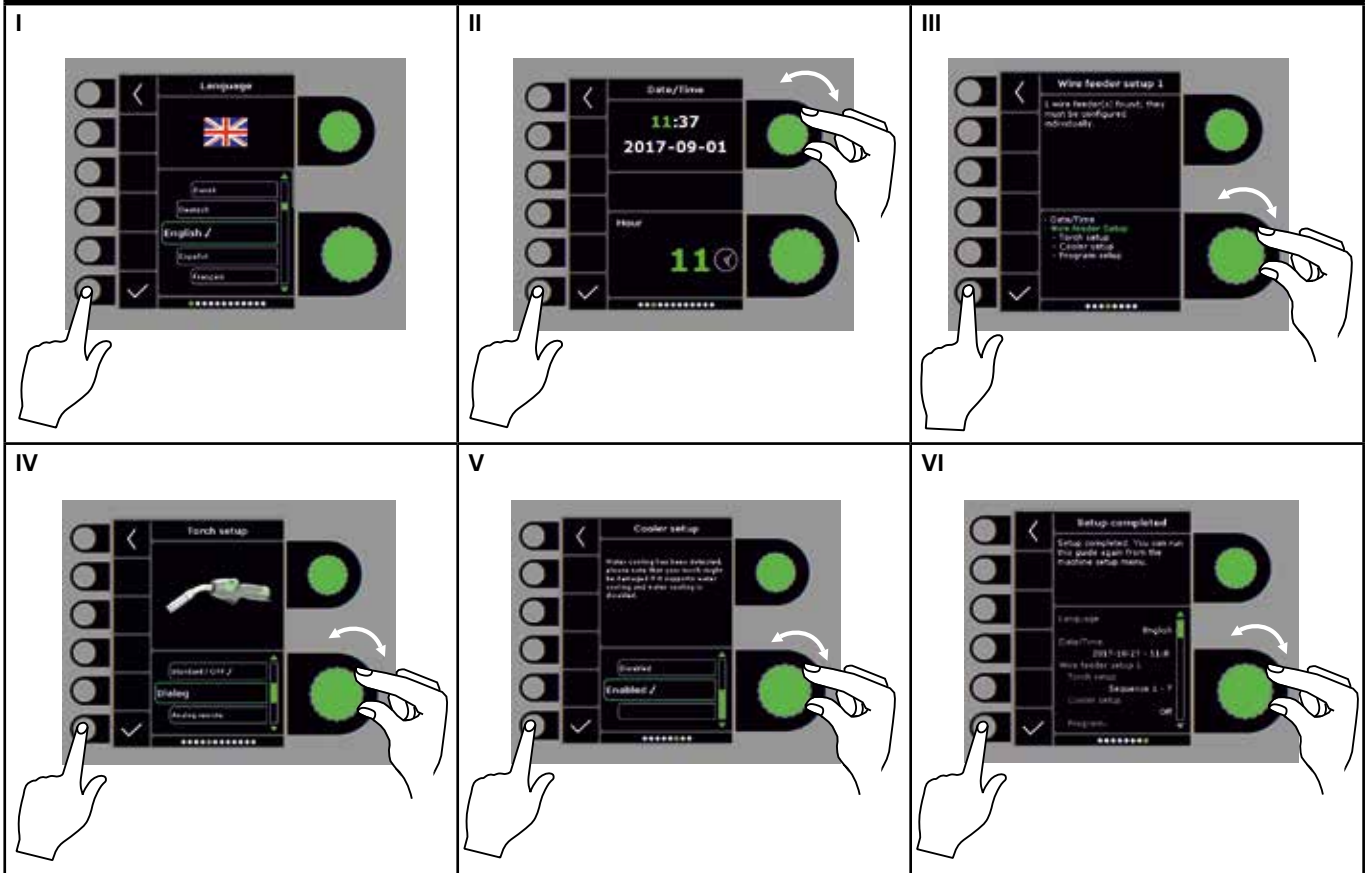

Lukitustoiminto

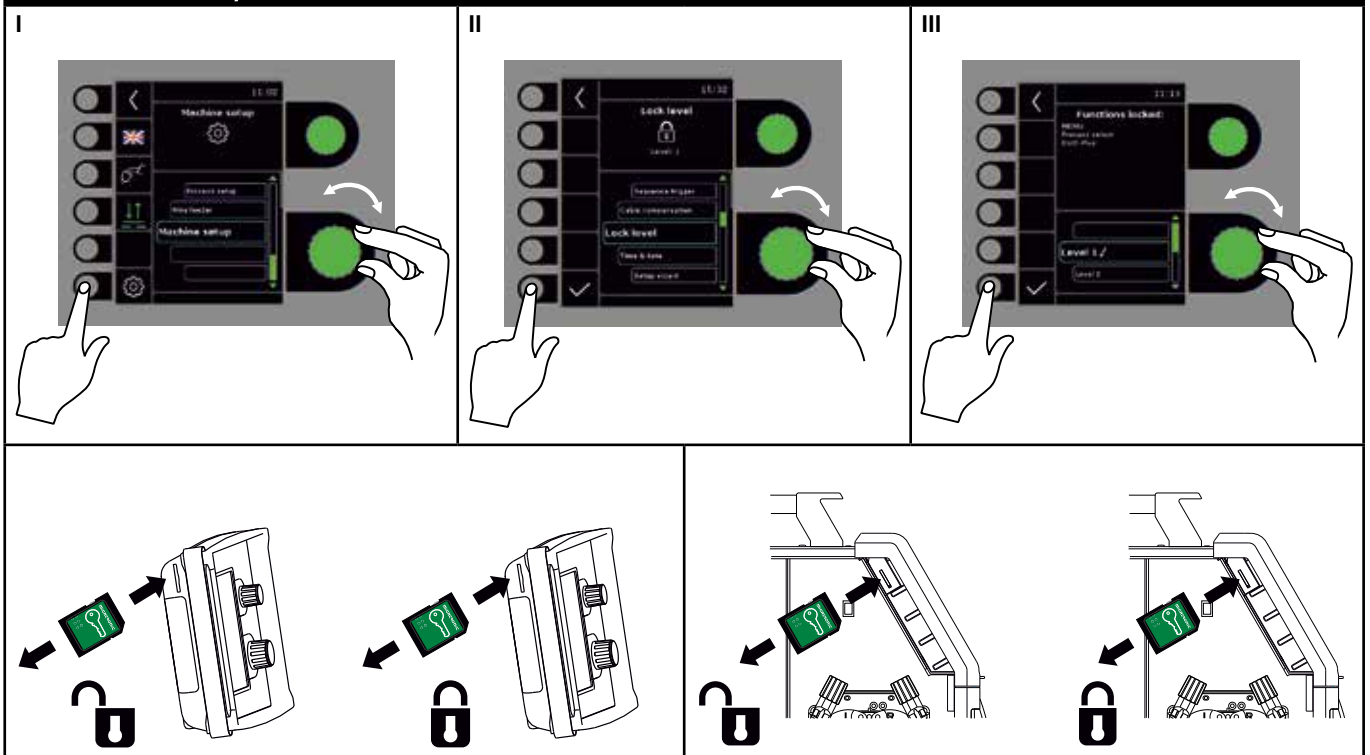

GRAPHICAL - Erikoistoiminnot

Ohjelmistot / Lisenssit

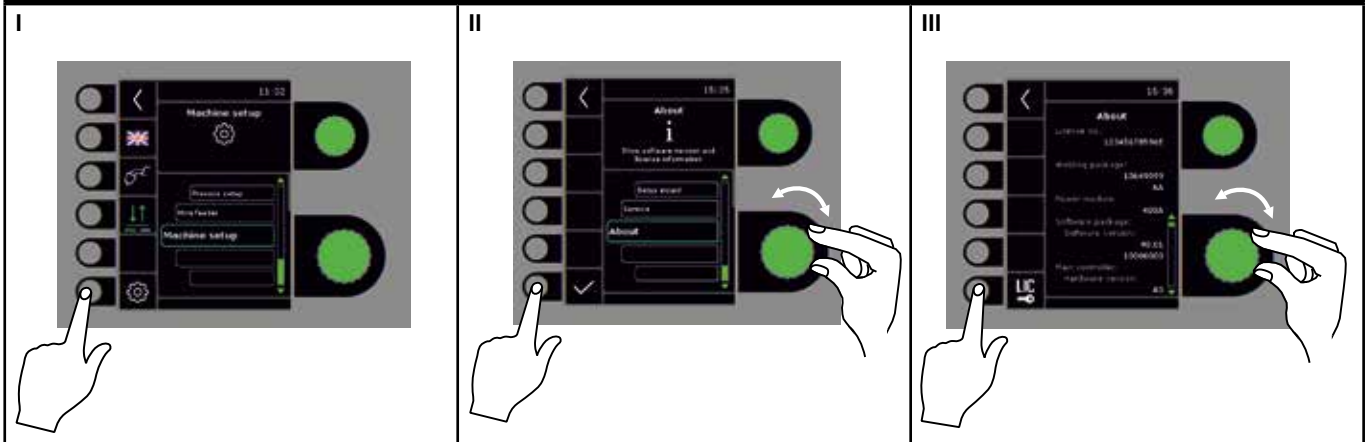

Kaapelikompensaatio (Hitsauskaapelin vastuksen kalibrointi)

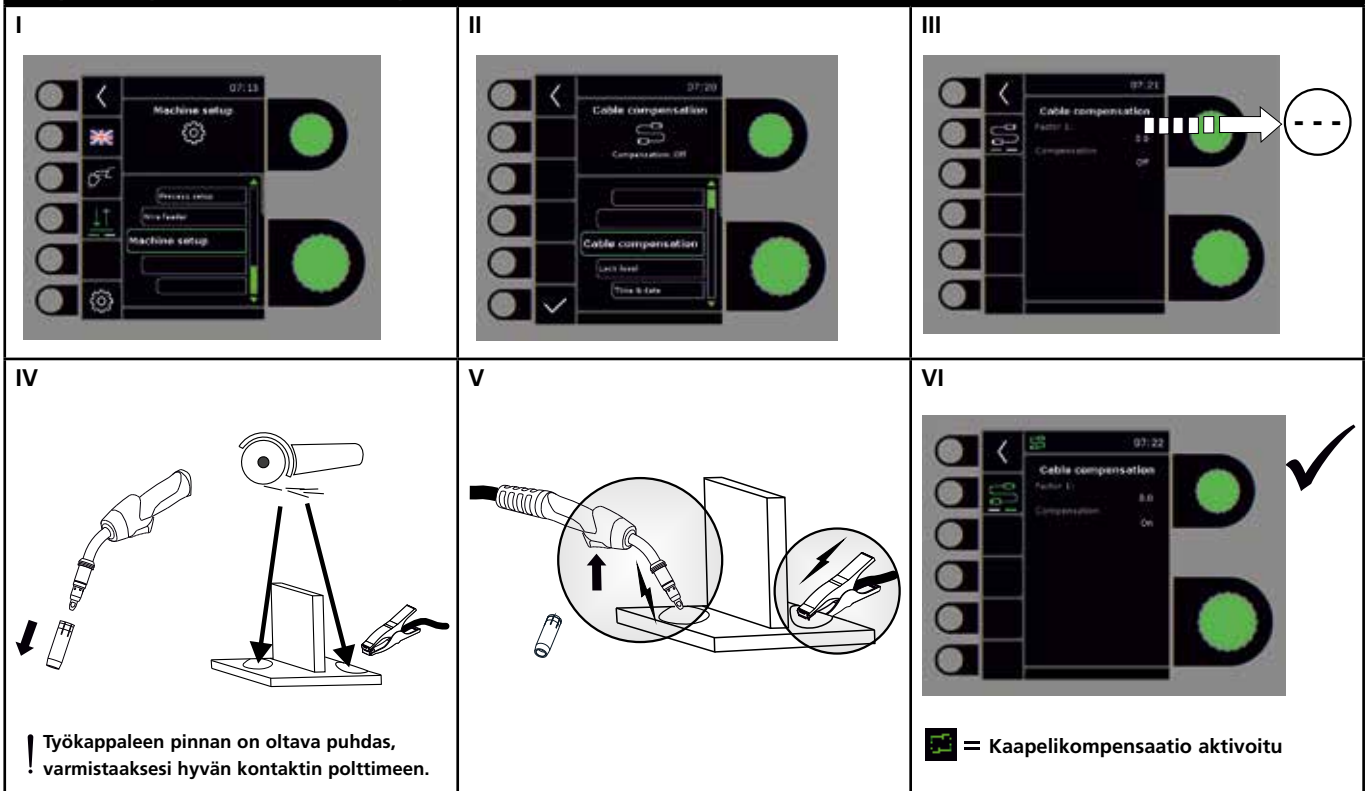

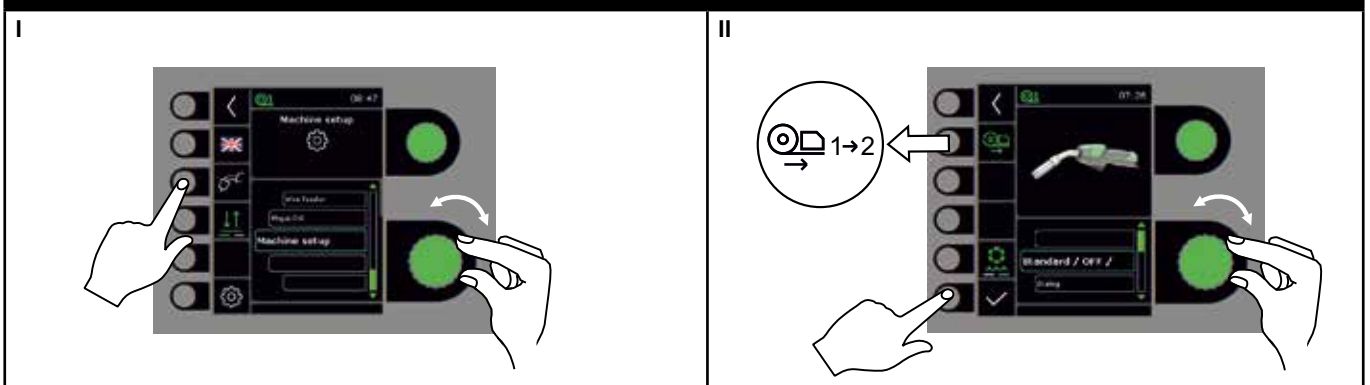

Polttimen asetus

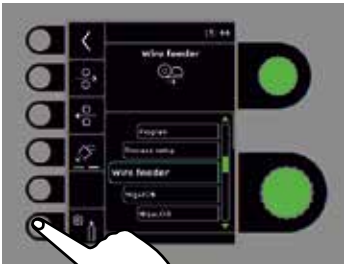

GRAPHICAL - Erikoistoiminnot

Kaasuvirtauksen kalibrointi (ei kaikissa malleissa)

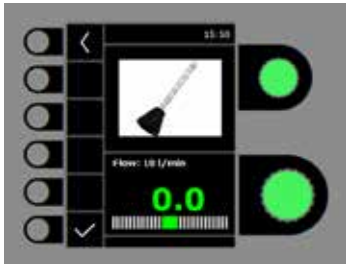
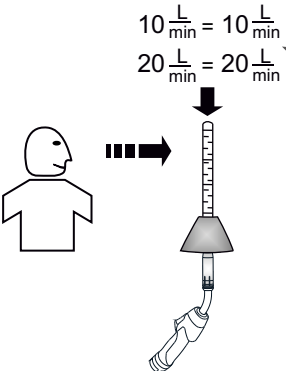
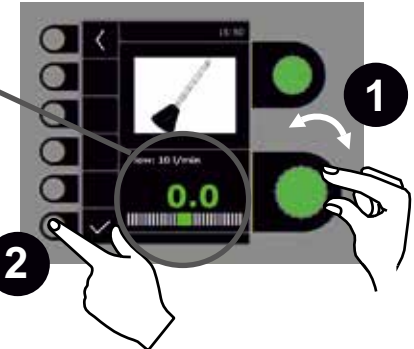
<p>I</p> 	<p>II</p> 	<p>III</p> 
<p>IV</p> 	<p>V</p> 	

GRAPHICAL - Virheiden käsittely

SIGMA Select on pitkälle kehitetty sisäinen suojausjärjestelmä. Vian ilmetessä kone keskeyttää kaasun ja virran syötön sekä pysäyttää langansyötön automaattisesti.

Havaittu vika:

Vika hitsauspolttimen jäähtymässä

Virtauksenvarijalla (water flow kit) varustetussa hitsauskoneessa vikakoodi osoittaa viallisen liitännän tai letkuntukkeutumisen siinä tapauksessa, että jäähdytysneste ei pääse virtaamaan. Tarkista jäähdytysletkujen kiinnitykset ja liitännät, täytä vesisäiliö ja tarkista hitsausletku haaroineen.

Jos jäähdytysnesteen viskositeetti laskee alhaisen lämpötilan vuoksi, vakio Migatroniic-jäähdytysneste on vaihdettava 99290515 BTC-20 NF jäähdytysnesteeseen, jolle on ominaista erittäin alhainen johtavuus ja korkea viskositeetti aina -17 °C:n lämpötiloihin asti. Huuhtelee jäähdytysjärjestelmä ennen uudentyypisen jäähdytysnesteen lisäämistä.



Lyhyt painallus ✓ -näppäimellä poistaa vikakoodin.

Vika kaasunsyötössä (IGC)

Kaasuvirtaus on liian vähäinen tai liian suuri. Varmista, että kaasuvirran paine on yli 2 bar ja alle 6 bar, vastaten arvoja 5 l/min ja 27 l/min. Kaasuvirhe saadaan pois toiminnasta säätämällä kaasuvirtaus manuaalisesti arvoon 27 l/min.

Kaasuvirhe poistuu lyhyellä painalluksella ✓ -näppäimestä.

Huomio: On tärkeää, että asetettu kaasunsyöttö voidaan säilyttää hitsauksen aikana.

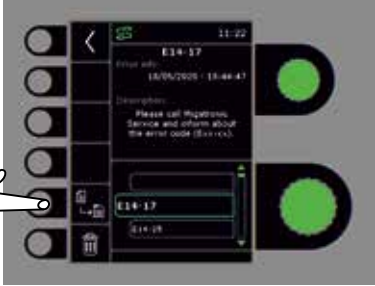
Vikalista		
I 	II 	III 
IV Vikalista Kaikki toimintahäiriöt on tallennettu koneen Menu Service -valikkoon. Vikalistan voi tallentaa SD-kortille painamalla allaolevaa näppäintä: Vikaluettelo on nyt tallennettu. Vikaluettelo voidaan poistaa "roskakoriin" asettamalla luku nollaan ja painamalla näppäintä.		

Tekniset tiedot 1

VIRTUALÄHDE SIGMA Select	300		300 IAC		400		400 IAC		550	
Verkköjännite ±15% (50-60Hz), V	3x400		3x400		3x400		3x400		3x400	
Minimi generaattorin koko, kVA	16		19		27		29		40	
¹⁾ Minimi oikosulkuteho Ssc, MVA	3,7		4,3		6,0		6,0		9,5	
Sulake, A	16		16		20		20		35	
Verkkovirta tehollinen, A	11,0		16,0		17,5		16,5		27,2	
Maksimiverkkovirta, A	15,4		18,3		26,0		28,2		39,2	
Kulutus 100%, kVA	9,0		11,1		12,1		11,4		18,9	
Kulutus max., kVA	10,7		12,7		18,0		19,5		27,1	
Tyhjäkäyntikulutus, W	11		13		12		13		12	
Hyötysuhde, %	87		85		89		85		90	
Tehokerroin	0,90		0,90		0,90		0,90		0,90	
	MIG	MMA	MIG	MMA	MIG	MMA	MIG	MMA	MIG	MMA
Virta-alue, tasavirta, A	15-300	15-250	15-300	15-300	15-400	15-400	15-400	15-400	15-550	15-550
Kuormitettavuus 100% 20°C, A	290/28,5	250/30,0	300/29,0	300/32,0	345/31,5	345/33,8	310/29,5	310/32,5	475/37,8	475/39,0
Kuormitettavuus maksimi 20°C, A/%N					400/65/34,0	400/65/36,0	400/60/34,0	400/60/36,0	550/60/41,5	550/60/42,0
Kuormitettavuus 100% 40°C, A/V	220/25,0	220/28,8	270/27,5	270/30,8	300/29,0	300/32,0	280/28,0	280/31,2	430/35,5	430/37,2
Kuormitettavuus 60% 40°C, A/V	240/26,0	230/29,2			370/32,5	370/34,8	350/31,5	350/34,0	510/39,5	510/40,4
Kuormitettavuus maksimi 40°C, A/%N	300/25/29,0	250/40/30,0	300/80/29,0	300/80/32,0	400/50/34,0	400/45/36,0	400/40/34,0	400/40/36,0	550/50/41,5	550/50/42,0
Tyhjäkäyntijännite, V	50-60		65-70		65-70		65-70		75-80	
²⁾ Käyttöluokka, C // S	S/CE // S/CE		S/CE // S/CE		S/CE // S/CE		S/CE // S/CE		S/CE // S/CE	
³⁾ Suojausluokka	IP23S		IP23		IP23		IP23		IP23	
Standardit, C	IEC60974-1, IEC60974-5, IEC60974-10 Cl. A									
Standardit, S	IEC60974-1, IEC60974-10 Cl. A									
Mitat C (KxLxP), mm	700x260x735		700x260x735		700x260x735		700x260x735		700x260x735	
Mitat S (KxLxP), mm	454x260x735		454x260x735		454x260x735		454x260x735		454x260x735	
Paino C / S, kg	36,9 / 26		53 / 36		52 / 35		53 / 36		53 / 36	

VIRTUALÄHDE SIGMA Select	300 Boost				300 IAC Boost			
Verkköjännite ±10% (50-60Hz), V	3x208-380				3x380-440			
Minimi generaattorin koko, kVA	16				25			
¹⁾ Minimi oikosulkuteho Ssc, MVA	1,7				3,75			
Sulake, A	20				16			
Verkkovirta tehollinen, A	19,5				10,6			
Maksimiverkkovirta, A	31,6				16,2			
Kulutus 100%, kVA	7,1				7,0			
Kulutus max., kVA	11,0				10,6			
Tyhjäkäyntikulutus, W	45				16			
Hyötysuhde, %	82				87			
Tehokerroin	0,95				0,95			
	MIG	MMA	MIG	MMA	MIG	MMA	MIG	MMA
Virta-alue, tasavirta, A	15-300	15-250	15-300	15-250	15-300	15-300	15-300	15-300
Kuormitettavuus 100% 20°C, A	250/26,5		250/26,5		300/29,0	300/32,0	300/29,0	300/32,0
Kuormitettavuus maksimi 20°C, A/%N	300/40/29,0		300/40/29,0					
Kuormitettavuus 100% 40°C, A/V	200/24,0	200/28,0	200/24,0	200/28,0	250/26,5	220/28,8	250/26,5	220/28,8
Kuormitettavuus 60% 40°C, A/V	210/24,5	210/28,4	210/24,5	210/28,4	270/27,5	250/30,0	270/27,5	250/30,0
Kuormitettavuus maksimi 40°C, A/%N	300/25/29,0	250/35/30,0	300/25/29,0	250/35/30,0	300/35/29,0	300/30/32,0	300/35/29,0	300/30/32,0
Tyhjäkäyntijännite, V	50-60				70-75			
²⁾ Käyttöluokka, C // S	S/CE // S/CE				S/CE // S/CE			
³⁾ Suojausluokka	IP23S				IP23			
Standardit, C	IEC60974-1, IEC60974-5, IEC60974-10 Cl. A							
Standardit, S	IEC60974-1, IEC60974-10 Cl. A							
Mitat C (KxLxP), mm	700x260x735				900x260x735			
Mitat S (KxLxP), mm	454x260x735				654x260x735			
Paino C / S, kg	45 / 34				66 / 49			

1) Tämä virtalähde täyttää EN / IEC61000-3-12:2014 (/ 2011) standardin vaatimukset ehdolla, että sähköverkon oikosulkuteho Ssc on suurempi tai yhtä suuri kuin taulukossa mainituissa tiedoissa sähkönsyötön ja julkisen sähköverkon välisessä liittytapisteesä. Sähköasentajan ja käyttäjän vastuulla on huolehtia tarvittaessa sähkönkajelijan avustuksella, että laite on kytketty vain sellaiseen sähkönsyöttöön, jonka oikosulkuteho on suurempi tai yhtä suuri kuin ilmoitettu arvo.

2) S Tämä kone täyttää ne vaatimukset, jotka koneilta vaaditaan työskennellessä alueilla, joilla on suuri sähköiskun vaara.

3) Kone on suunniteltu sisä- ja ulkokäyttöön suojausluokan IP23 / IP23S mukaisesti.

IP23S: Kone voidaan varustoida, mutta sitä ei ole tarkoitettu käytettäväksi ulkona sateen aikana, ellei sitä ole suojattu

Tekniset tiedot 2

VIRTUALÄHDE SIGMA Select	400 Boost				400 IAC Boost			
Verkköjännite ±10% (50-60Hz), V	3x208-380		3x380-440		3x208-380		3x380-440	
Minimi generaattorin koko, kVA	25		25		25		25	
¹⁾ Minimi oikosulkuteho Ssc, MVA					4,0		4,0	
Sulake, A	25-50		25-50		25-50		25-50	
Verkkovirta tehollinen, A	22,0		11,7		24,8		11,8	
Maksimiverkkovirta, A	45,0		23,5		48,0		24,5	
Kulutus 100%, kVA	8,3		8,1		8,5		8,5	
Kulutus max., kVA	16,7		16,3		17,4		17,4	
Tyhjäkäyntikulutus, W	60		56		60		71	
Hyötysuhde, %	84		88		82		85	
Tehokerroin	0,96		0,95		0,96		0,96	
	MIG	MMA	MIG	MMA	MIG	MMA	MIG	MMA
Virta-alue, tasavirta, A	15-400	15-400	15-400	15-400	15-400	15-400	15-400	15-400
Kuormitettavuus 100% 20°C, A	300/29,0	300/32,0	300/29,0	300/32,0	300/29,0	300/32,0	300/29,0	300/32,0
Kuormitettavuus maksimi 20°C, A/%V	400/30/34,0	400/30/32,0	400/30/34,0	400/30/32,0	400/30/34,0	400/30/32,0	400/30/34,0	400/30/32,0
Kuormitettavuus 100% 40°C, A/V	250/26,5	220/28,8	250/26,5	220/28,8	250/26,5	220/28,8	250/26,5	220/28,8
Kuormitettavuus 60% 40°C, A/V	280/28,0	260/30,4	280/28,0	260/30,4	280/28,0	260/30,4	280/28,0	260/30,4
Kuormitettavuus maksimi 40°C, A/%V	400/25/34,0	400/20/36,0	400/25/34,0	400/20/36,0	400/25/34,0	400/20/36,0	400/25/34,0	400/20/36,0
Tyhjäkäyntijännite, V	70-75				70-75			
²⁾ Käyttöluokka, C // S	S/CE // S/CE				S/CE // S/CE			
³⁾ Suojausluokka	IP23				IP23			
Standardit, C	IEC60974-1, IEC60974-5, IEC60974-10 Cl. A				IEC60974-1, IEC60974-5, IEC60974-10 Cl. A			
Standardit, S	IEC60974-1, IEC60974-10 Cl. A				IEC60974-1, IEC60974-10 Cl. A			
Mitat C (KxLxP), mm	900x260x735				900x260x735			
Mitat S (KxLxP), mm	654x260x735				654x260x735			
Paino C / S, kg<	66 / 49				67 / 50			

LANGANSYÖTTÖYKSIKKÖ MWF			
Langansyöttönopeus, m/min	0,5-30,0		
Pistoolin liitäntä	EURO		
Lankakelan läpimitta, mm	300		
Lankakela, kg	5-18		
Kuormitettavuus 100 % 40°C, A/%	430		
Kuormitettavuus 60% 40°C, A/%	500		
Kuormitettavuus maksimi 40°C A/%	550/50		
³⁾ Suojausluokka	IP23		
Langan halkaisija, mm	0,6-1,6		
Kaasun MPa (bar)	0,6 (6,0)		
	MWF 30	MWF 32	MWF 33
Mitat (KxLxP), mm	413x310x750	457x260x672,5	457x260x672,5
Paino, kg	11,6	14,0	14,0
Standardit	IEC60974-5, IEC60974-10 CL. A		

JÄÄHDYTYKSIKKÖ MCU 1300	
Jäähdytysteho (1 l/min), W	1300
Jäähdytysteho (1,5 l/min), W	1600
Säiliön tilavuus, litraa	5
Virtaus, bar - °C - l/min	3,0-60-1,5
Maksimipaine, bar	5
Standardit	IEC60974-2, IEC60974-10 CL.A
Mitat (KxLxP), mm	207x260x680
Paino, kg	20

EY-VAATIMUSTENMUKAISUUSVAKUUTUS

CE

Me, **MIGATRONIC A/S**
Aggersundvej 33
9690 Fjerritslev
Dänemark

vakuutamme täten, että valmistamamme alla mainittu kone

malli: SIGMA Select

täyttää direktiivien: 2014/35/EU
2014/30/EU
2011/65/EU vaatimukset.

Eurooppalaiset standardit: EN IEC60974-1:2018/A1:2019
EN IEC60974-2:2019
EN IEC60974-5:2019
EN / IEC60974-10:2014/A1:2015

Asetus: 2019/1784/EU

Fjerritslev 10.02.2021

Kristian M. Madsen

Kristian M. Madsen
CEO

- Tämä virtalähde täyttää EN / IEC61000-3-12:2014 (/ 2011) standardin vaatimukset ehdolla, että sähköverkon oikosulkuteho Ssc on suurempi tai yhtä suuri kuin taulukossa mainituissa tiedoissa sähkönsyötön ja julkisen sähköverkon välisessä liittymäpisteessä. Sähköasentajan ja käyttäjän vastuulla on huolehtia tarvittaessa sähkönkajelijan avustuksella, että laite on kytketty vain sellaiseen sähkönsyöttöön, jonka oikosulkuteho on suurempi tai yhtä suuri kuin ilmoitettu arvo.
- S** Tämä kone täyttää ne vaatimukset, jotka koneilta vaaditaan työskennellessä alueilla, joilla on suuri sähköiskun vaara.
- Kone on suunniteltu sisä- ja ulkokäyttöön suojausluokan IP23 / IP23S mukaisesti.
IP23S: Kone voidaan varustoida, mutta sitä ei ole tarkoitettu käytettäväksi ulkona sateen aikana, ellei sitä ole suojattu

DENMARK:

Main office

MIGATRONIC A/S

Aggersundvej 33, DK-9690 Fjerritslev, Denmark
Tel. +45 96 500 600, www.migatronicon.com

MIGATRONIC AUTOMATION A/S

Knøsgårdvej 112, DK-9440 Aabybro, Denmark
Tel. +45 96 96 27 00, www.migatronicon-automation.com

MIGATRONIC EUROPE:

Great Britain

MIGATRONIC WELDING EQUIPMENT LTD

21 Jubilee Drive, Belton Park, Loughborough
GB-Leicestershire LE11 5XS, Great Britain
Tel. +44 01509/267499, www.migatronicon.com

France

MIGATRONIC EQUIPEMENT DE SOUDURE S.A.R.L.

Parc Avenir II, 313 Rue Marcel Merieux
FR-69530 Brignais, France
Tel. +33 04 78 50 65 11, www.migatronicon.com

Italy

MIGATRONIC s.r.l. IMPIANTI PER SALDATURA

Via Dei Quadri 40, IT-20871 Vimercate (MB), Italy
Tel. +39 039 9278093, www.migatronicon.com

Norway

MIGATRONIC NORGE AS

Industriveien 6, N-3300 Hokksund, Norway
Tel. +47 32 25 69 00, www.migatronicon.com

Czech Republic

MIGATRONIC CZ a.s.

Tolstého 451, CZ-415 03 Teplice 3, Czech Republic
Tel. +420 411 135 600, www.migatronicon.com

Holland

MIGATRONIC NEDERLAND B.V.

Ericssonstraat 2, NL-5121 ML Rijen, Holland
Tel. +31 (0)161-747840, www.migatronicon.com

Sweden

MIGATRONIC SVETSMASKINER AB

Nåäs Fabriker, Box 5015,S-448 50 Tollerød, Sweden
Tel. +46 031 44 00 45, www.migatronicon.com

Germany

MIGATRONIC SCHWEISSMASCHINEN GMBH

Sandusweg 12, D-35435 WETTENBERG-LAUNSBACH, Germany
Tel. +49 0641/98284-0, www.migatronicon.com

Hungary

MIGATRONIC KERESKEDELMI KFT.

Futó utca 37. 6. emelet, H-1082 Budapest, Hungary
Tel. +36 70 630 0604 www.migatronicon.com

MIGATRONIC ASIA:

India

MIGATRONIC INDIA PRIVATE LTD.

No.22 & 39/20H Sowri Street,
IN-Alandur, Chennai – 600 016, India
Tel. +91 44 2233 0074 www.migatronicon.com